



# RED SWASTIKA SCHOOL

## 2015 SEMESTRAL ASSESSMENT 2 SCIENCE PRIMARY 5

Name : \_\_\_\_\_ (     )

Class : Primary 5/ \_\_\_\_\_

Date : 2 November 2015

### BOOKLET A

Total time for Booklets A & B: 1h 45 min

Booklet A: 30 questions (60 marks)

**Note:**

1. Do not open the booklet until you are told to do so.
2. Read carefully the instructions given at the beginning of each part of the booklet.
3. Do not waste time. If the question is too difficult for you, go on to the next question.
4. Check your answers thoroughly and make sure you attempt every question.
5. In this booklet, you should have the following:
  - a. Page 1 to Page 22
  - b. Questions 1 to 30

**Section A**

For Questions 1 to 30, choose the most suitable answer and shade its number in the OAS provided.

1. The snail curls into its shell quickly when touched.

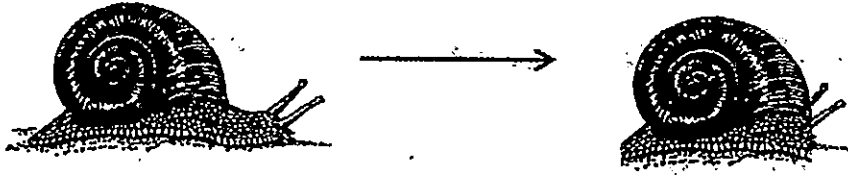

This shows that the snail is a living thing because it \_\_\_\_\_.

- (1) can move
- (2) can reproduce
- (3) can respond to changes
- (4) needs air, water and food to survive

2. Study the flow chart below.

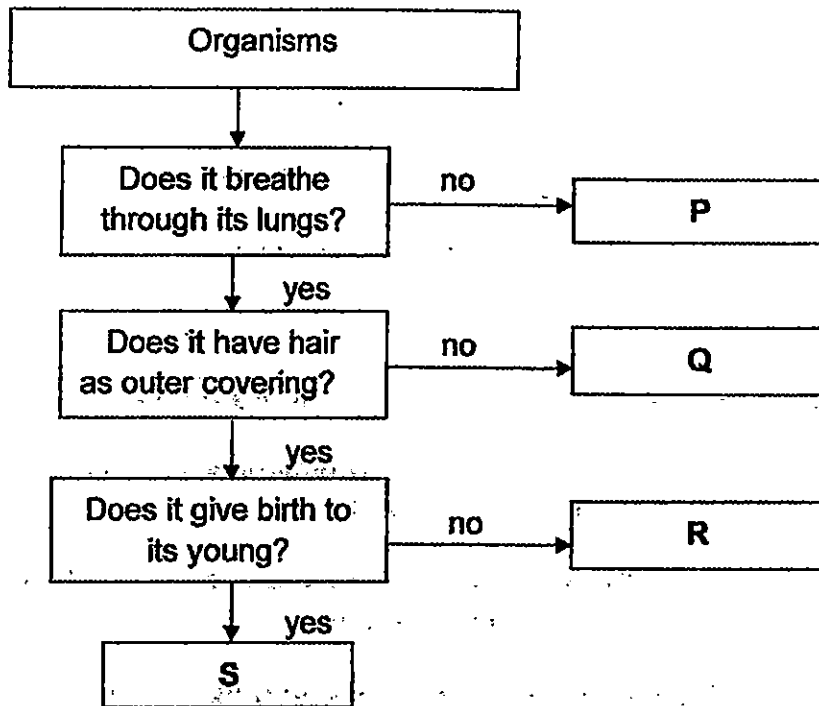

Which letter would best represent a "dog"?

- (1) P
- (2) Q
- (3) R
- (4) S

3. Some aquatic plants were kept in two sealed glass jars as shown below.

Set-up P is exposed to light.

Set-up Q is kept in the dark.

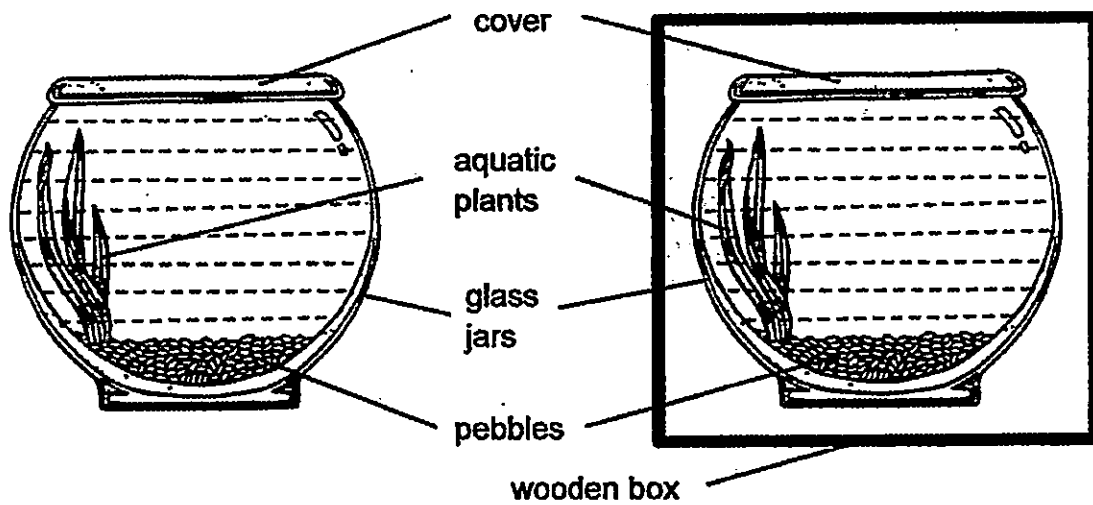

At the end of two weeks, only the plants in set-up P were alive. What does the results of this experiment show?

- (1) Plants need light to survive.
- (2) Plants need pebbles to survive.
- (3) Plants need water to survive.
- (4) Plants need air to survive.

4. In which part(s) of the human digestive system is/are digestive juices added?

- A: stomach
- B: small intestine
- C: large intestine
- D: anus

- (1) A only
- (2) B and C only
- (3) A and B only
- (4) C and D only

5. Study the diagram shown. It shows the human respiratory system.

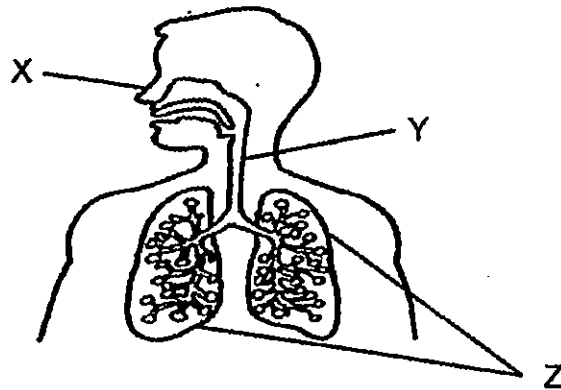

Which of the following statements about the system is not true?

- (1) X has fine hairs inside that trap dust in the air that we breathe in.
- (2) Y is the main tube that carries air between part X and part Z.
- (3) Z has many blood vessels that take in carbon dioxide into the body.
- (4) X allows gases to be removed when we breathe out.

6. The table below gives some information on four plants, P, Q, R and S. A tick (✓) indicates the presence of the characteristic of the plant.

Characteristic \ Plant	P	Q	R	S
It has seeds.		✓		✓
It has spores.	✓		✓	
It takes in dissolved oxygen.		✓	✓	

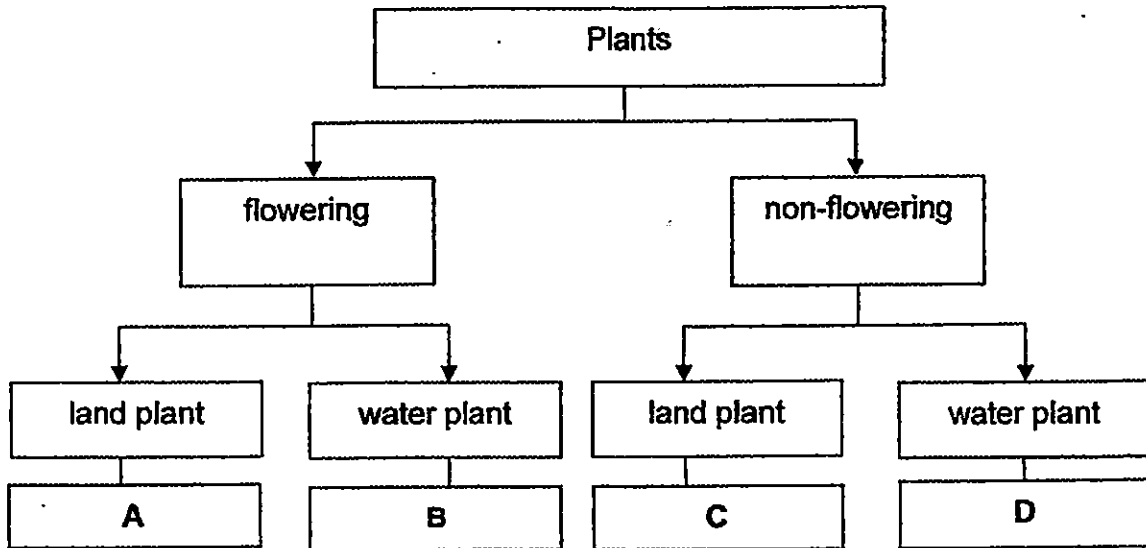

Based on the information above, which of the following shows the correct classification of the plants?

	Plant P	Plant Q	Plant R	Plant S
(1)	A	B	C	D
(2)	B	C	A	D
(3)	C	B	D	A
(4)	D	A	C	B

7. Jasmine set up the experiment as shown below. Both set-ups A and B were placed in a lighted room for a week. The water in set-up A and the plants in set-ups A and B were changed daily. She observed that one grasshopper died after a week.

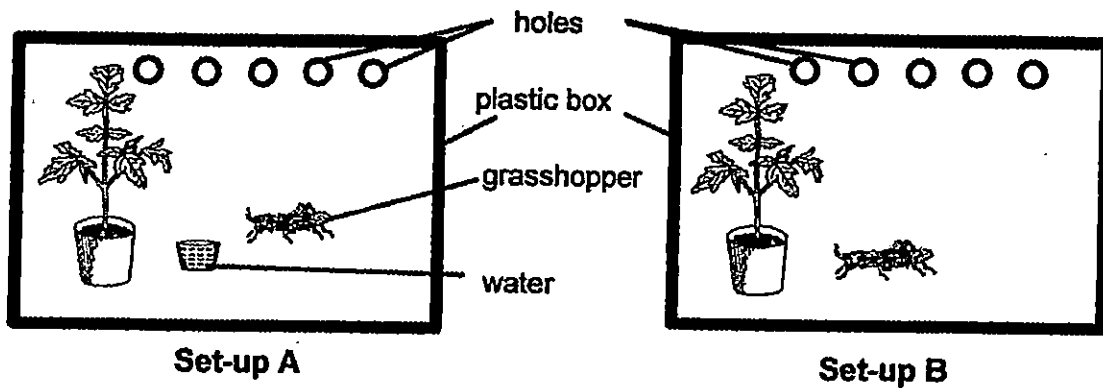

What is the aim of this experiment?

Her aim is to find out whether the presence of \_\_\_\_\_.

- (1) water affect the survival of the plants
- (2) water affect the survival of the grasshopper
- (3) oxygen affect the survival of the plants
- (4) oxygen affect the survival of the grasshopper

8. Kai Ming studied three cells, A, B and C, under a microscope and recorded his observations in the table below.

Cell Part	Cells		
	A	B	C
Nucleus	present	present	present
Cell wall	present	absent	present
Chloroplast	present	absent	absent
Cell membrane	present	present	present

Based on the information above, which of the following is correct?



	A	B	C
(1)	cheek cell	leaf cell	onion cell
(2)	leaf cell	cheek cell	onion cell
(3)	onion cell	leaf cell	cheek cell
(4)	cheek cell	onion cell	leaf cell

9. A group of people discovered an island and named it Jurassiz. They collected data on the number and position of plants found on it. They recorded this data in the map below.

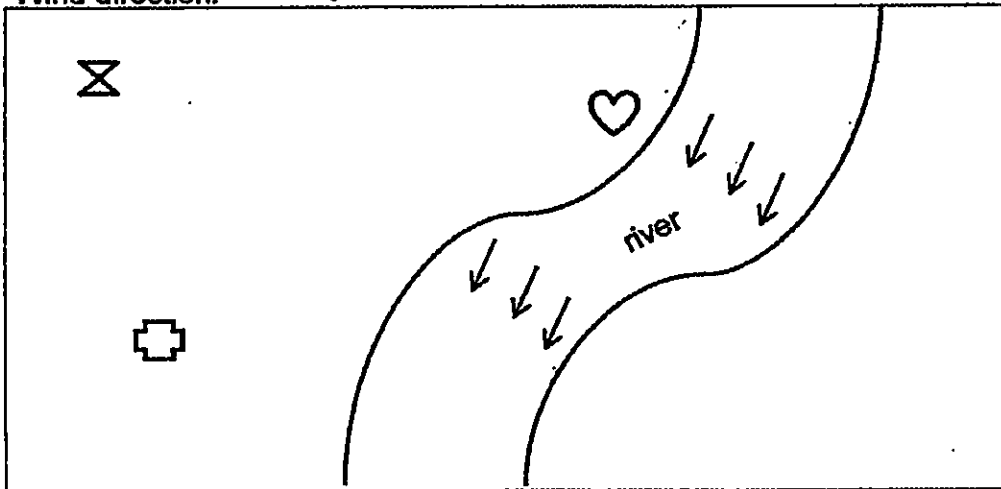
Wind direction: →



**Legend**  
Plants:



- 
- 
- 

The same group of people then returned one year later and discovered that more plants were found growing on the island as shown below.

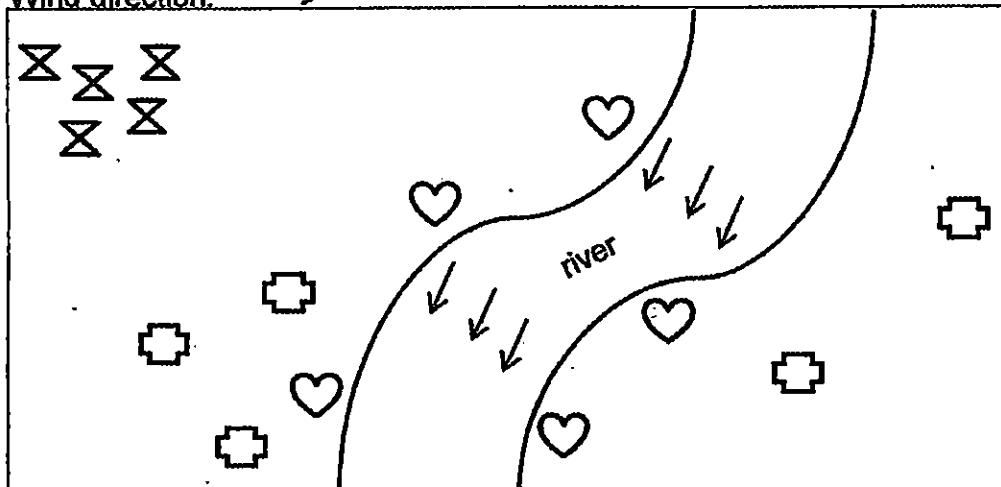
Wind direction: →



Which of the following best represents the method of seed dispersal of the three types of plants?

			
(1)	wind	animal	water
(2)	water	splitting open forcefully	animal
(3)	animal	wind	splitting open forcefully
(4)	splitting open forcefully	water	wind

10. Study the table below.

	Description of characteristics
A	attached earlobes
B	ability to roll tongue
C	natural straight hair
D	short fingernails

Which of the characteristics can be passed on from parents to their children?

- (1) A and D only
- (2) B and C only
- (3) A, B and C only
- (4) B, C and D only

11. Study the flow chart below.

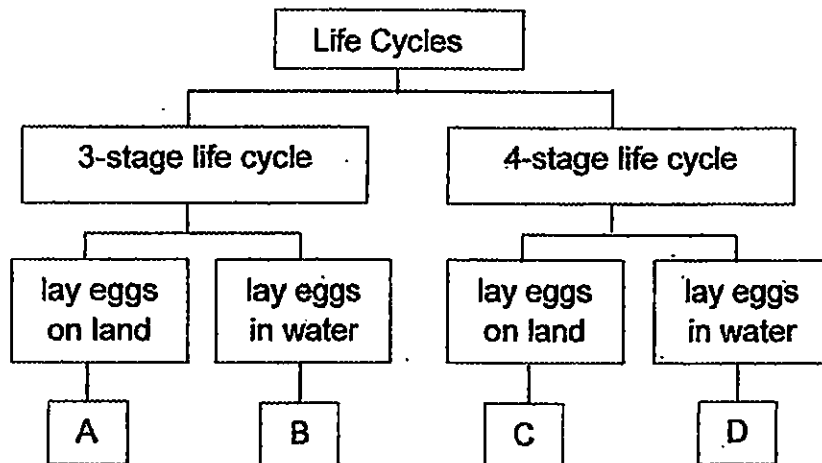

Which one of the following represents animals, A, B, C and D?

	A	B	C	D
(1)	chicken	mosquito	butterfly	frog
(2)	frog	chicken	mosquito	butterfly
(3)	chicken	frog	butterfly	mosquito
(4)	frog	mosquito	chicken	butterfly



12. Brenda was given four set-ups, A, B, C and D, with similar plants placed in identical containers as shown below. She wanted to conduct an experiment to find out if the roots of a plant take in water. There was 500 ml of water in each container. The set-ups were located on a table in a garden.

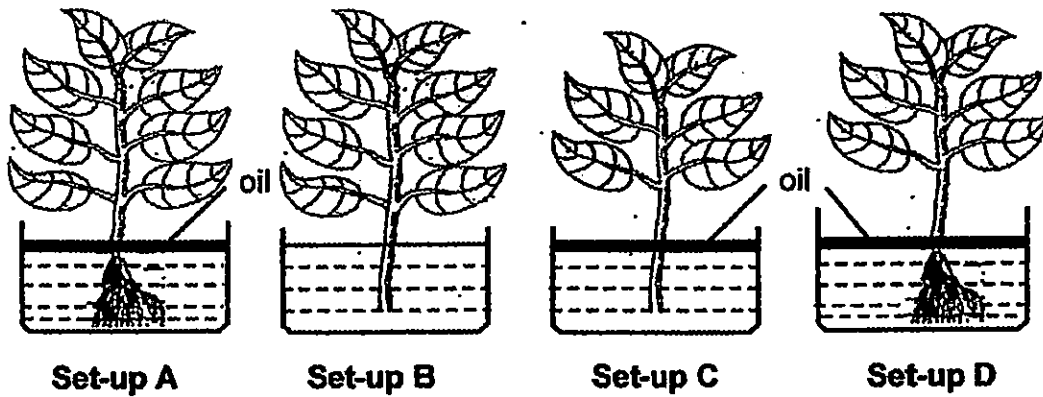

She measured the amount of water left in the containers to conclude her experiment.

Which two set-ups should she use in her experiment to ensure a fair test?

- (1) A and B
- (2) B and C
- (3) B and D
- (4) C and D

13. Some students participated in the activity shown during the recent School Carnival Day.

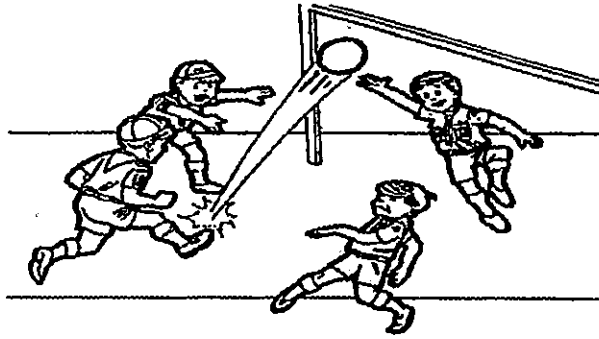

Which human systems stated below are needed to perform these activities?

- A: Muscular system
- B: Skeletal system
- C: Respiratory system
- D: Circulatory system

- (1) A and B only
- (2) C and D only
- (3) A, C and D only
- (4) A, B, C and D

14. Clarice wanted to find out whether the position of bulbs would affect the brightness of the bulbs. She used new batteries, bulbs and wires in her experiment. The length of the wire used in circuits X and Y is the same. She set up two circuits, X and Y, as shown in the circuit diagrams below.

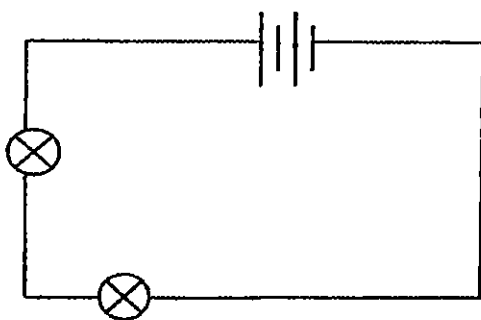

**Circuit X**

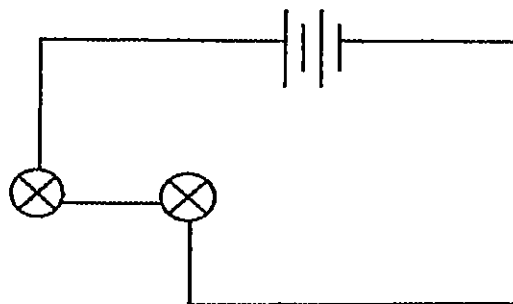

**Circuit Y**

What would be the conclusion for her experiment?

- (1) The brightness of the bulbs in X and Y is the same.
- (2) The brightness of bulbs in X is dimmer than that in Y.
- (3) The brightness of bulbs in Y is dimmer than that in X.
- (4) The bulbs in X remain unlit but the bulbs in Y lit up.

15. Jahida set up a circuit below. Three bulbs lighted up when she closed the switch. She was told that one of the objects in the circuit was an insulator of electricity.

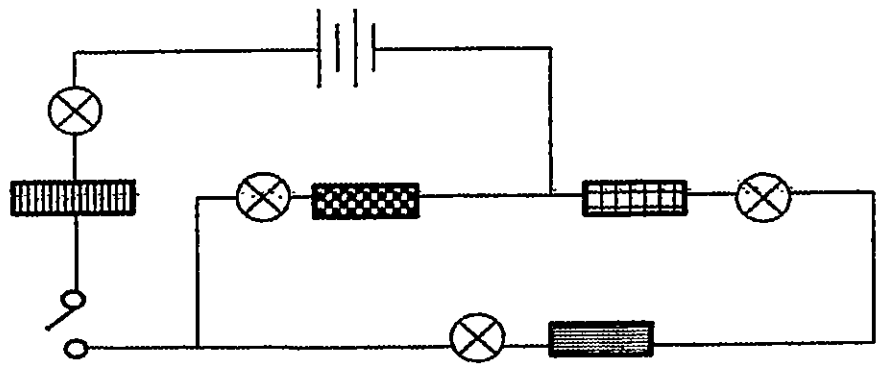

Which one of the following objects was the insulator of electricity?

- (1)
- (2)
- (3)
- (4)

16. Nicole drew the arrangement of bulbs in diagram 1. She wanted a circuit such that there would be one coloured bulb lighted up at any point in time by closing only one switch each time.

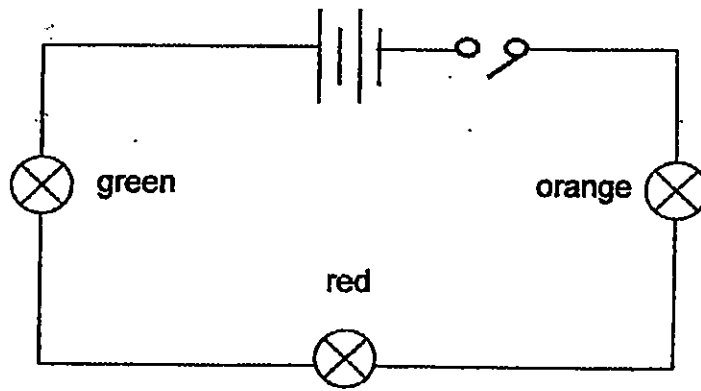
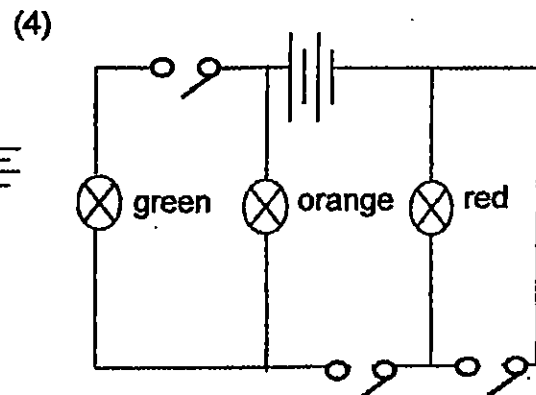
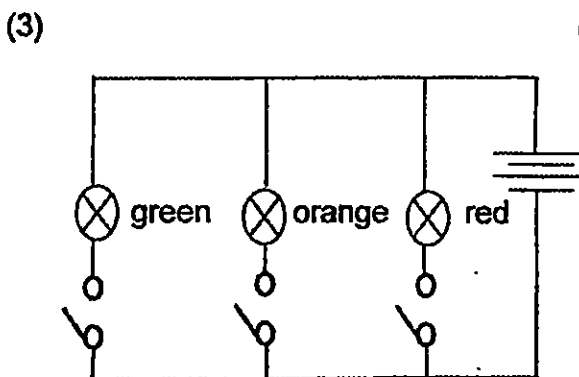
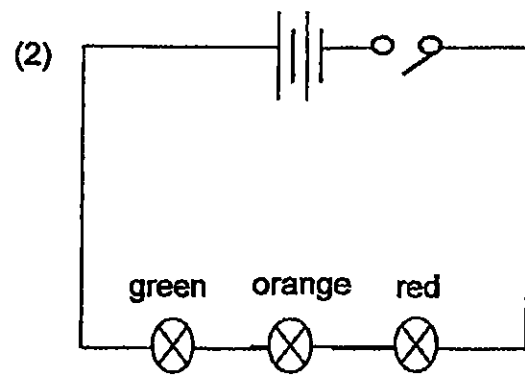
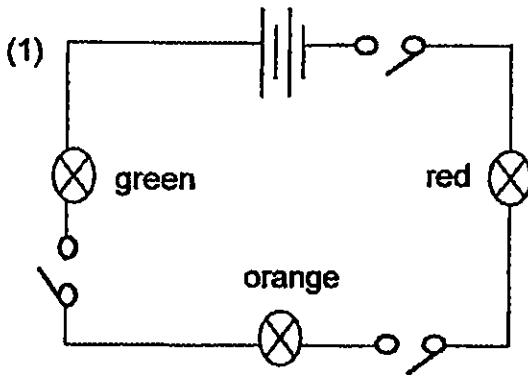

Diagram 1

Her father said that the arrangement of her light bulbs would not work according to what she wanted. Then, Nicole changed the circuit diagram so that it would work correctly.

Which of the following best matches the correct circuit arrangement?



17. Ben used a circuit tester to test a circuit card.

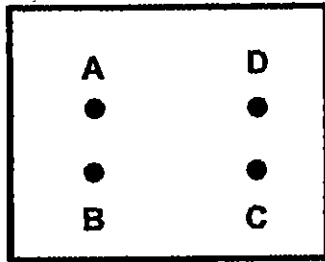

Circuit card

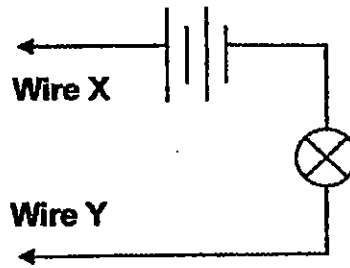

Circuit tester

The table below shows what happened to the bulb when each pair of clips, A, B, C, and D were tested.

Clips tested	Bulb in circuit tester
A and B	unlit
A and C	lit
C and D	lit
B and C	unlit
A and D	lit

Which one of the following represents the correct circuit card?

(1)

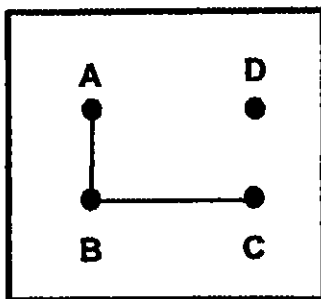

(2)

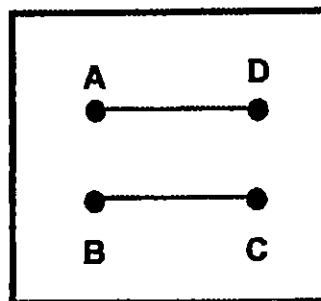

(3)

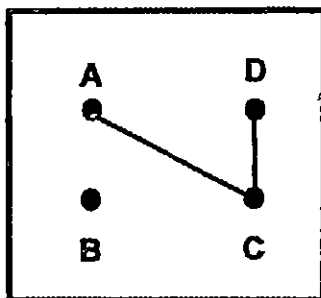

(4)

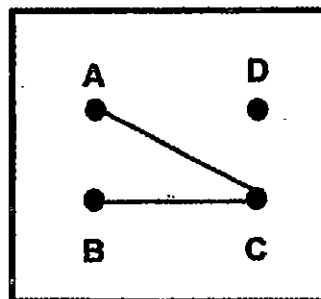

18. Xiao Ling sealed two identical glass bottles, W and X. Then, she left them on the table in the Science room. After some time, she noticed that water droplets were formed on the bottles as shown below.

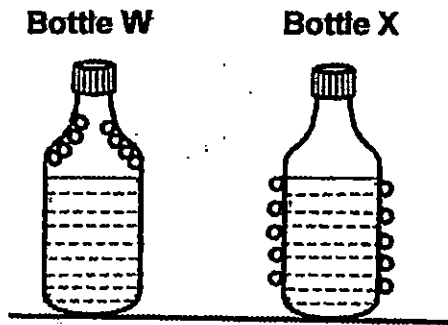

Based on the diagrams above, what type of water could bottles W and X contain?

	<b>Bottle W</b>	<b>Bottle X</b>
(1)	ice-cold water	hot water
(2)	hot water	ice-cold water
(3)	hot water	tap water
(4)	ice-cold water	tap water

19. The diagrams below show matter X in a container. The container is placed in three different positions on a table in the classroom.

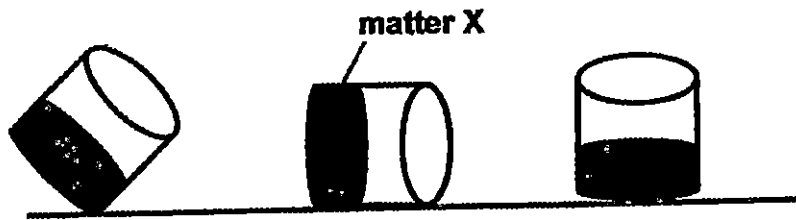

Based on the diagrams above, what could the state of matter for X most likely be?

- (1) solid
  - (2) liquid
  - (3) gas
  - (4) solid and liquid
20. The students lighted some candles on a birthday cake.

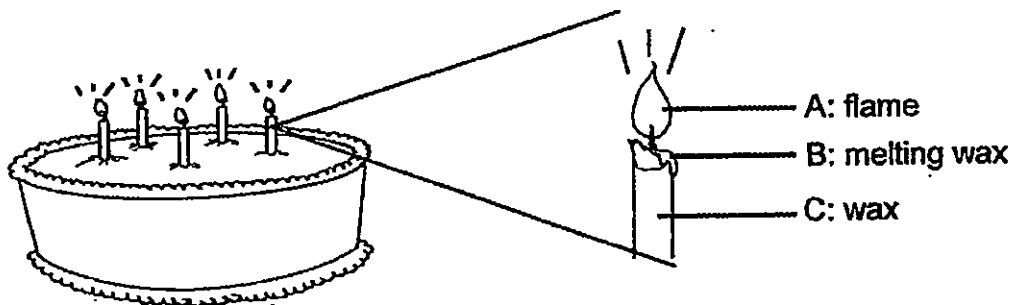

They made some observations about the candles and wrote their thoughts down into their journals.

Peter: The light at part A can be seen and occupies space.

May Leen: The melting wax at part B occupies space.

Bernard: The flame occupies space and there is heat given out.

Cathy: The wax at part C has no mass.

Which of the following students made the correct observation about matter?

- (1) Peter
- (2) May Leen
- (3) Bernard
- (4) Cathy

21. Lily attended a water conservation seminar. She summarised what she had learnt in the chart below.

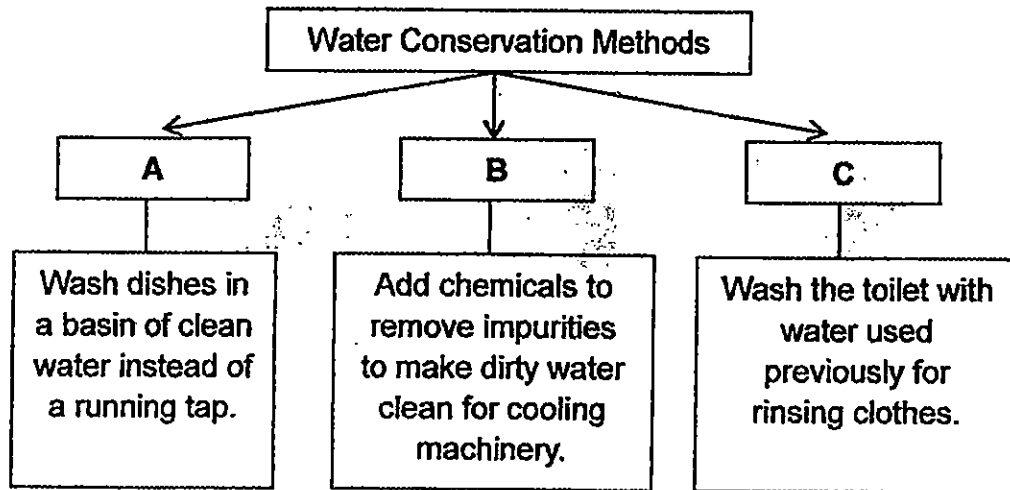

Which of the following best represents headings for A, B and C?

	<b>A</b>	<b>B</b>	<b>C</b>
(1)	Reuse	Reduce	Recycle
(2)	Recycle	Reduce	Reuse
(3)	Reuse	Recycle	Reduce
(4)	Reduce	Recycle	Reuse



22. Zann set up an experiment as shown below.

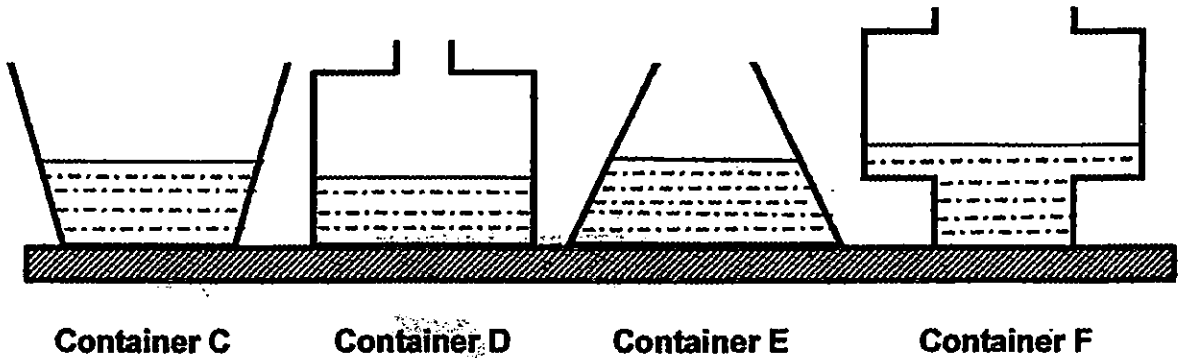

The same amount of water was poured into each of the containers. All the containers were placed in the Science room under similar conditions for two days.

Which of the following best represents the amount of water left in the containers after the experiment?

	Least	→			Most
(1)	C	F	E	D	
(2)	C	F	D	E	
(3)	E	D	F	C	
(4)	F	D	E	C	

23. The diagram shows the view of a road. There is a mirror located at the bend of the road. Car A and car B are travelling towards the bend in the direction shown by the arrows.

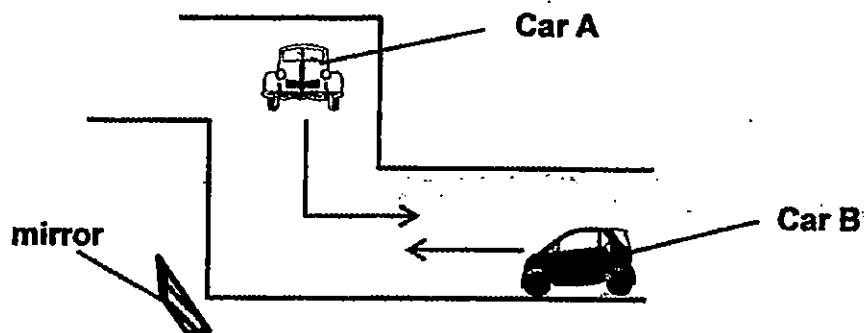

Which of the following properties of light enables the driver of car A to see car B before car B reaches the bend of the road?

- A: Light travels in a straight line.
- B: Light can be reflected by a mirror.
- C: When light is blocked, a shadow is formed.

- (1) B only
- (2) A and B only
- (3) A and C only
- (4) B and C only

24. Jamal took out some ice cubes from the freezer and left them on a plastic plate in the kitchen as shown. The temperature of the kitchen was 30°C.

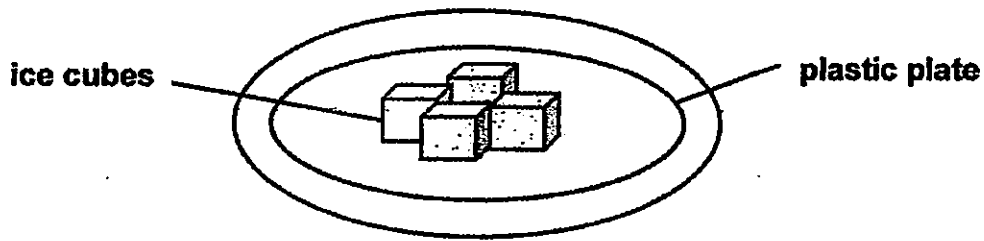

Which one of the statements below shows the heat changes that took place in the ice cubes after they were taken out from the freezer and left on the plate?

- (1) The ice cubes gained heat from the surroundings.
  - (2) The ice cubes lost heat to the plastic plate.
  - (3) The air in the surroundings gained heat from the ice cubes.
  - (4) The plastic plate gained heat from the ice cubes.
25. A group of students set up an experiment below. Sheets A, B, C, D and E are made of different materials. They have the same thickness and size. A heart-shaped cut-out was made on sheet A.

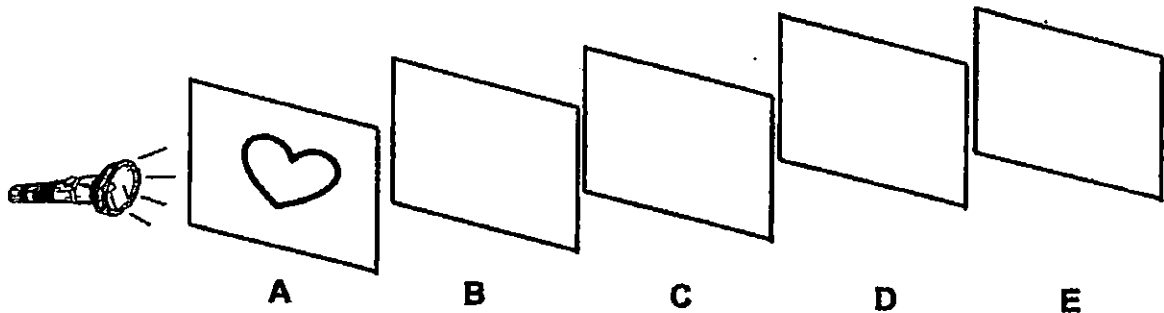

A patch of light was observed on sheet D when the torch was switched on.

Which of the observations shown in the table below is correct?

	It allows most light to pass through.	It does not allow light to pass through.	It is not possible to tell.
(1)	B, C	D	E
(2)	B, D	C	E
(3)	B, D	E	C
(4)	B, C	E	D

26. Study the interactions of magnets below.

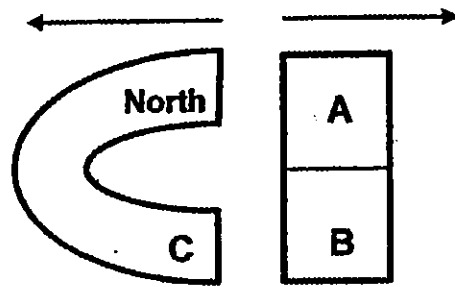

The two magnets repelled each other when they were brought towards each other. What are the poles of A, B and C?

	A	B	C
(1)	North-seeking pole	South-seeking pole	North-seeking pole
(2)	North-seeking pole	South-seeking pole	South-seeking pole
(3)	South-seeking pole	North-seeking pole	South-seeking pole
(4)	South-seeking pole	North-seeking pole	North-seeking pole

27. Lynn pulls a spring that is attached to a ceiling as shown below.

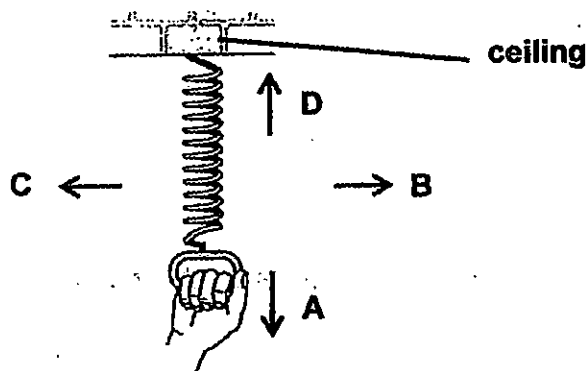

Which direction will the spring move towards when Lynn pulls it downwards?

- (1) A
- (2) B
- (3) C
- (4) D

28. Miffy carried out an experiment to test the magnetic strength of an iron nail when given a certain number of strokes. She used the North-seeking pole of the magnet to stroke the iron nail in the same direction. She recorded the number of paper clips the nail could attract and plotted a graph.

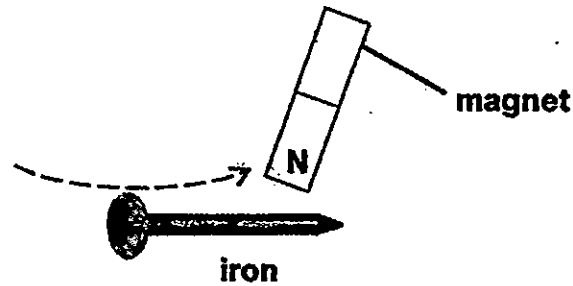

Which one of the graphs best represents the relationship between the number of strokes made and the number of paper clips the nail could attract?

(1)

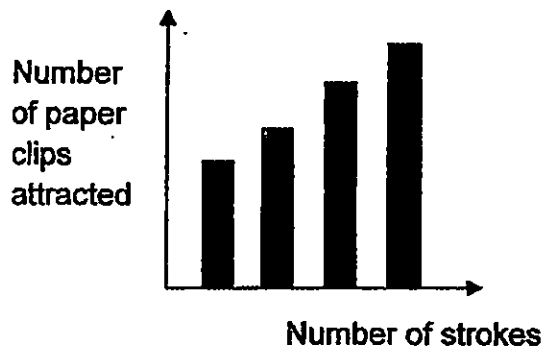

(2)

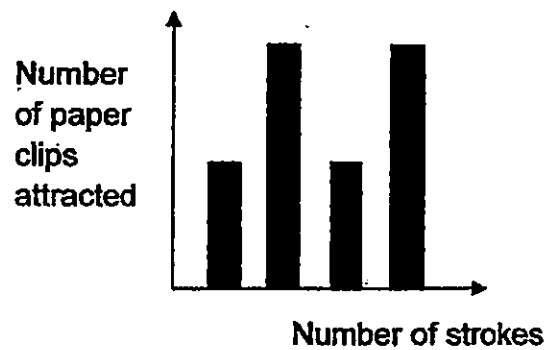

(3)

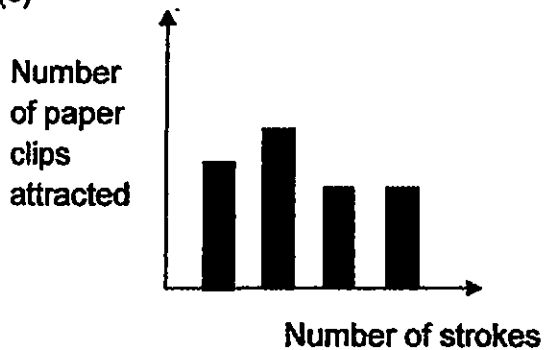

(4)

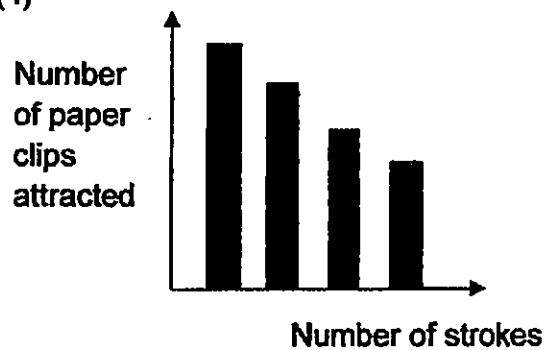

29. The diagram shows Jimmy playing table tennis with his cousin, Aden. When the ball came towards Jimmy, he swung his arm forward and used the bat to hit the ball.

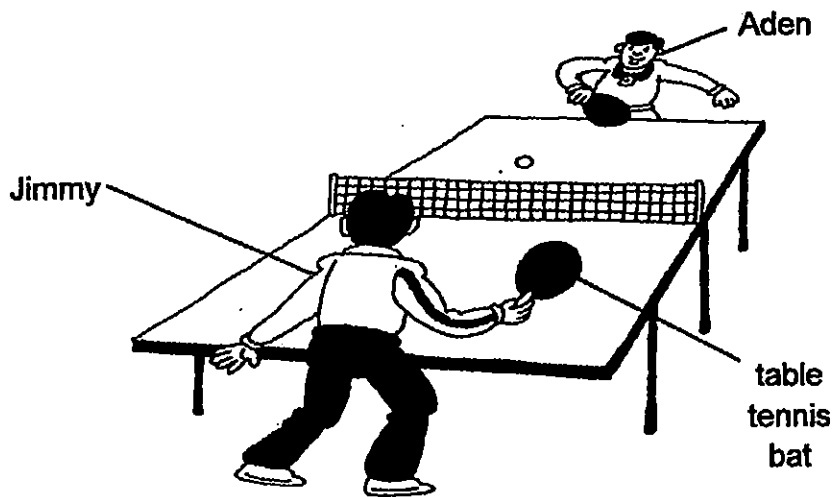

Based on the above scenario, which of the following statements are correct?



- A: Aden exerted a pull on the table tennis ball.
- B: Jimmy exerted a push on the table tennis ball.
- C: Jimmy exerted a force to change the direction of the table tennis ball.
- D: Jimmy exerted a force but could not change the direction of the table tennis ball.

- (1) A and B only
- (2) B and D only
- (3) A and C only
- (4) B and C only

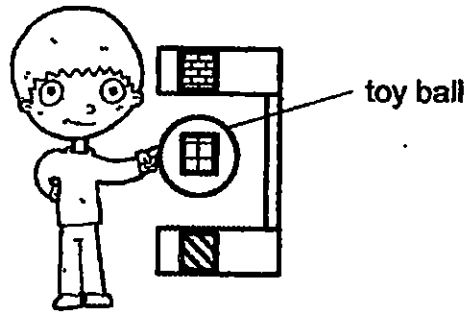













30. The diagram below shows a toy ball that is “floating” in the air between two parts. Henson rotates the ball by turning it with his finger. This toy ball works by making use of magnets.



Legend:

-  magnet
-  magnet
-  magnet

How should the magnets be placed for the toy ball to “float” in the air?

	(1)	(2)	(3)	(4)
				
				
				

**End of Section A**

**Please check your answers.**



# RED SWASTIKA SCHOOL

## 2015 SEMESTRAL ASSESSMENT 2 SCIENCE PRIMARY 5

Name : \_\_\_\_\_ (      )

Class : Primary 5/ \_\_\_\_\_

Date : 2 November 2015

### BOOKLET B

14 Questions  
40 Marks

In this booklet, you should have the following:

- Page 23 to Page 38
- Questions 31 to 44

### MARKS

	OBTAINED	POSSIBLE
BOOKLET A		60
BOOKLET B		40
TOTAL		100

Parent's Signature : \_\_\_\_\_



**SECTION B**

Answer all the questions in the spaces provided.

31. The chart below shows how some animals, C, D, E, and F, can be classified based on their characteristics.

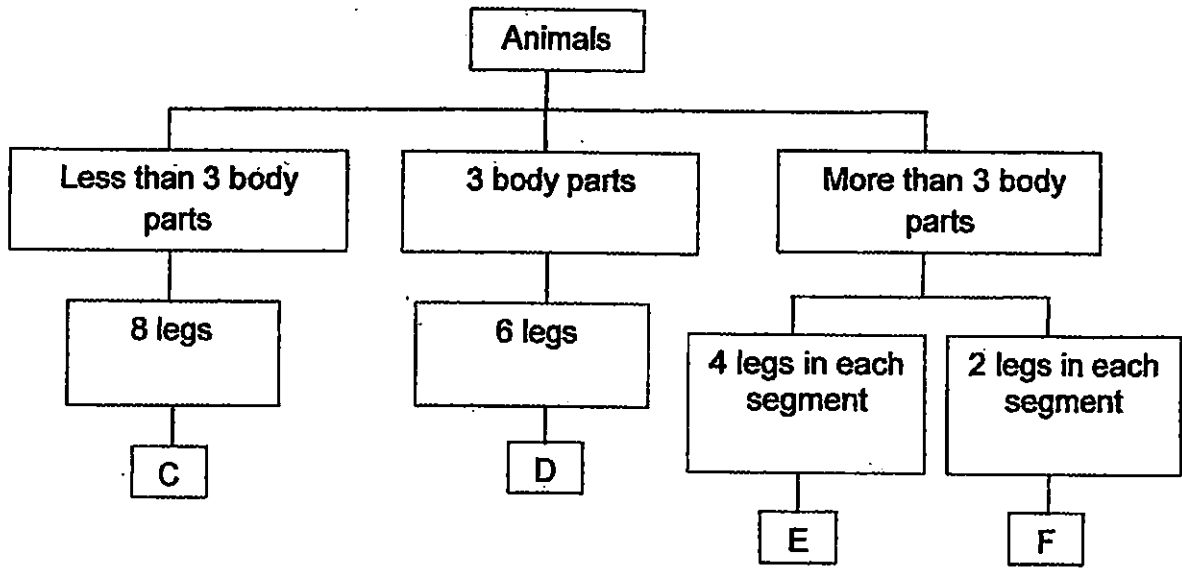

- (a) Based on the chart above, list the characteristics of C. (1m)

---

---

- (b) Based on the classification chart above, where should you classify the animal shown below? (1m)

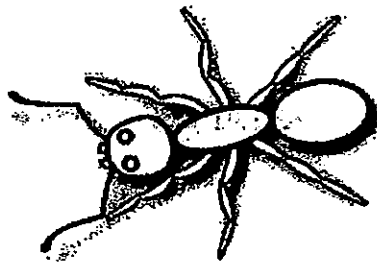

It should be classified in \_\_\_\_\_

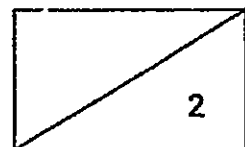

Kelvin wanted to investigate the effect of pollutant Y on the survival of water plant W using the materials provided below.

The materials that he used:

- 10 similar plant W
- 2 identical beakers, S and T
- 10 drops of pollutant Y
- 1 container containing 1000ml of water

- ;) Complete the table to show how Kelvin should carry out his experiment. Write the numbers (2 to 5) in the boxes provided in the table. The first step has been done.(1m)

Step	Procedure
1	Pour 500 ml of water into each beaker, S and T.
	Place both beakers in a sunny field for a week.
	Observe and count the number of plant(s) W that remained alive after one week.
	Put 5 water plant W into each beaker, S and T.
	Add 10 drops of pollutant Y into beaker S.

- i) Based on the answer in part (c), Kelvin's teacher told him that one of the beakers is a control set-up. Which beaker, S or T, is a control set-up? (1m)
- 

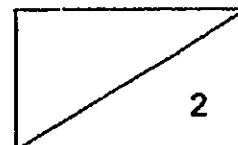

32. Bryan wanted to investigate how the temperature affected the rate of photosynthesis of plant Z. He used four similar set-ups as shown below. The water in each set-up was maintained at different temperatures throughout the experiment. The set-ups were exposed to similar light sources for two hours.

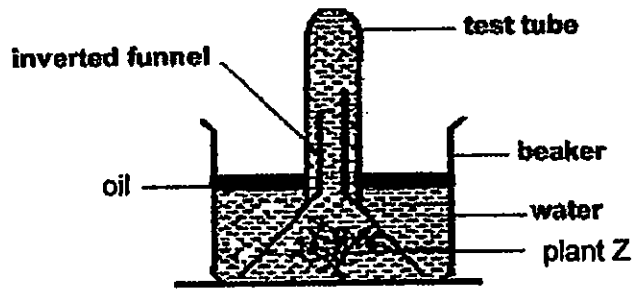

Bryan measured the amount of oxygen collected in the test tube of each set-up after two hours. Next, he used his data and plotted the following graph.

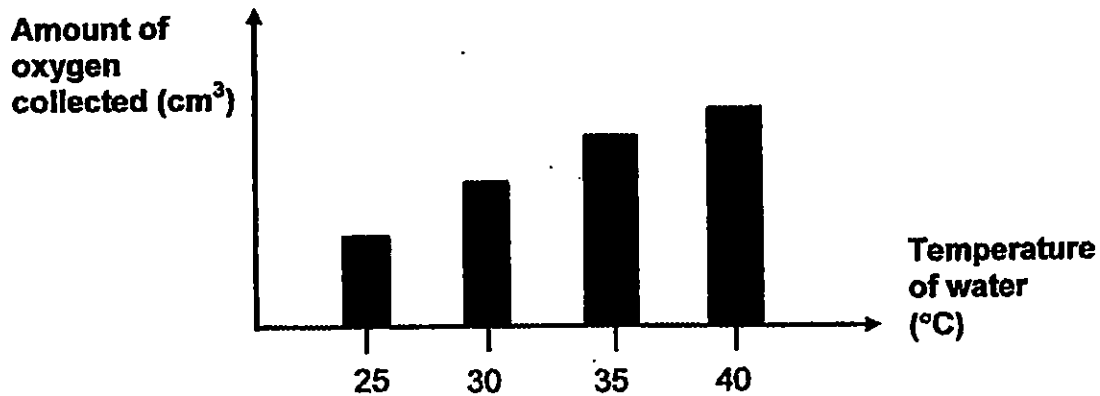

- (a) What is the effect of temperature on the rate of photosynthesis of plant Z? (1m)

---

---

- (b) Bryan observed that the level of water in the test tube decreased after two hours. Why is this so? (1m)

---

---

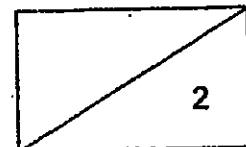

33. Raja set up an experiment as shown below. He placed animal X inside container A and used a delivery tube to connect it to container B filled with limewater as shown below.

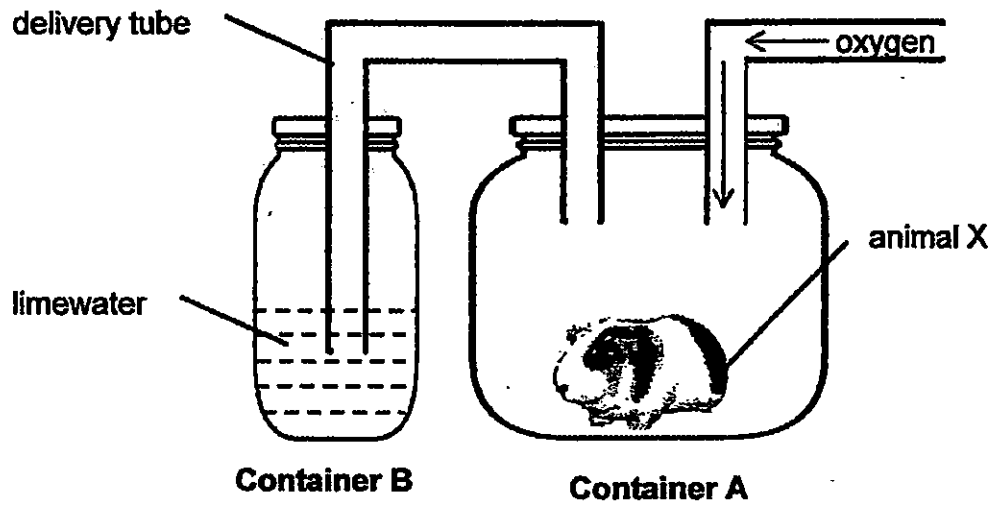

- (a) Raja observed that the limewater turned chalky after two hours. Explain why. (1m)

---

---

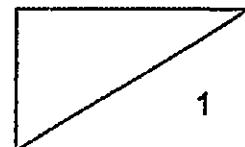

The diagram below shows the direction of blood flow in some parts of the human body.

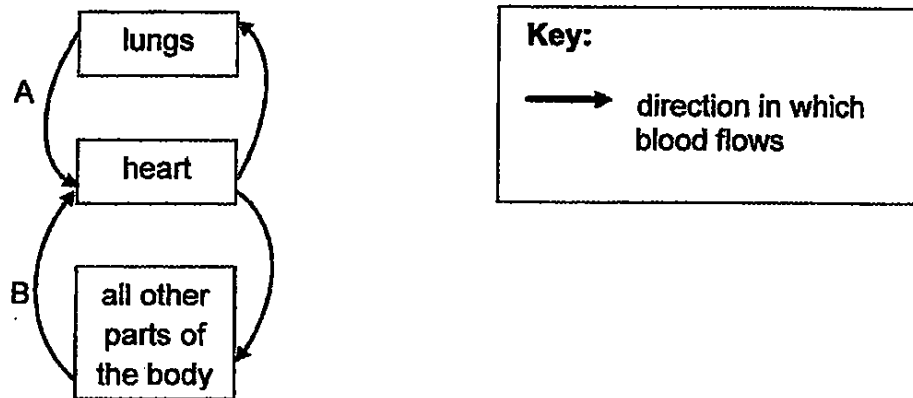

(b) Compare the amount of oxygen in the blood at A and B. Explain your answer. (2m)

---

---

---

---

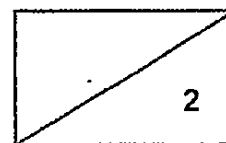

34. The diagram below shows a land plant.

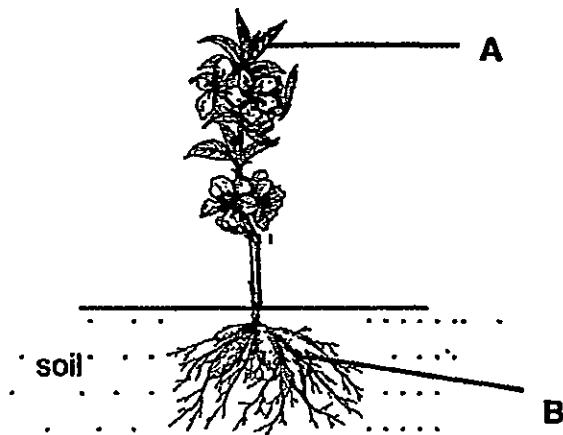

Study the three cells, S, T and R, carefully.

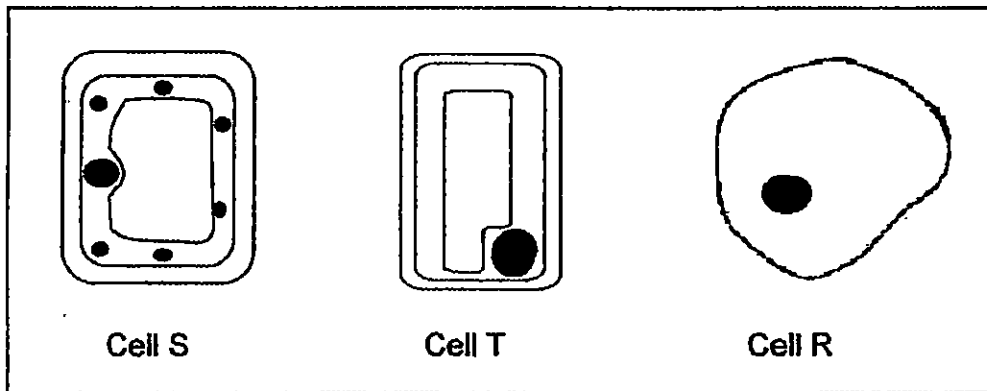

(a) State one similarity in cell parts among the cells, S, T and R. Do not mention size or shape. (1m)

\_\_\_\_\_

(b) Which cells, S, T or R, can be found in parts A and B of the plant respectively? (1m)

(i) Part A : Cell \_\_\_\_\_

(ii) Part B : Cell \_\_\_\_\_

(c) Explain which plant process that cell S can perform but cell T cannot. (1m)

\_\_\_\_\_

\_\_\_\_\_

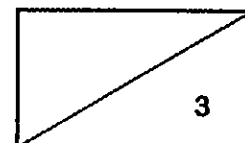

35. Look at the diagram below.

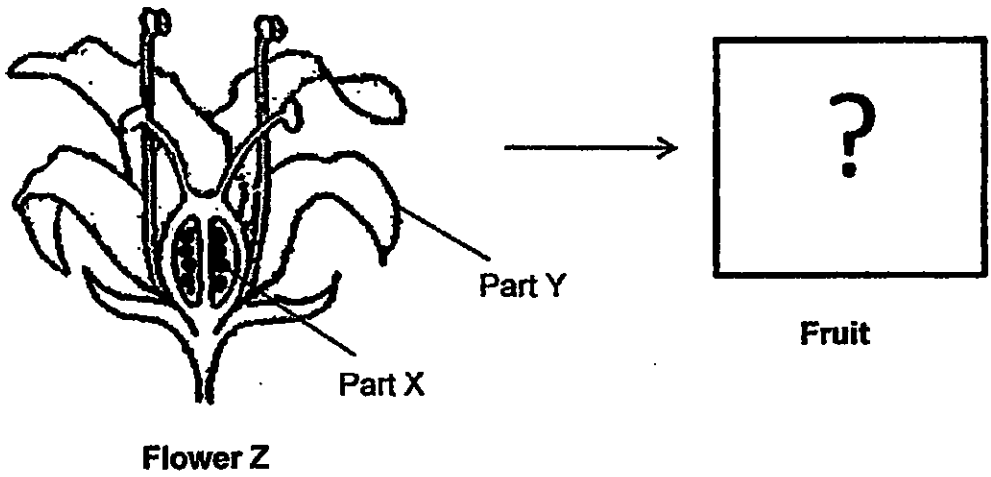

(a) Identify part X and part Y. (1m)

Part X: \_\_\_\_\_

Part Y: \_\_\_\_\_

Look at the two fruits, A and B, shown below.

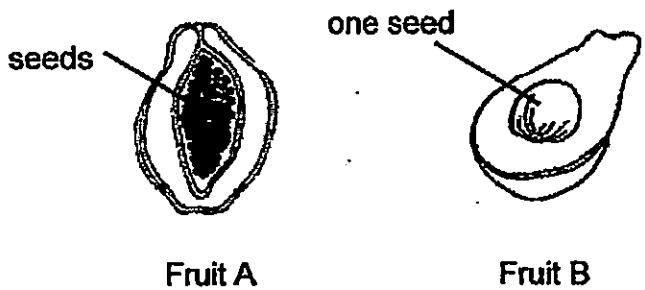

(b) Which fruit is most likely to be the fruit of Flower Z?  
Explain your answer. (2m)

---

---

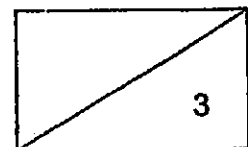

36. Study the family tree of Joash's family members.

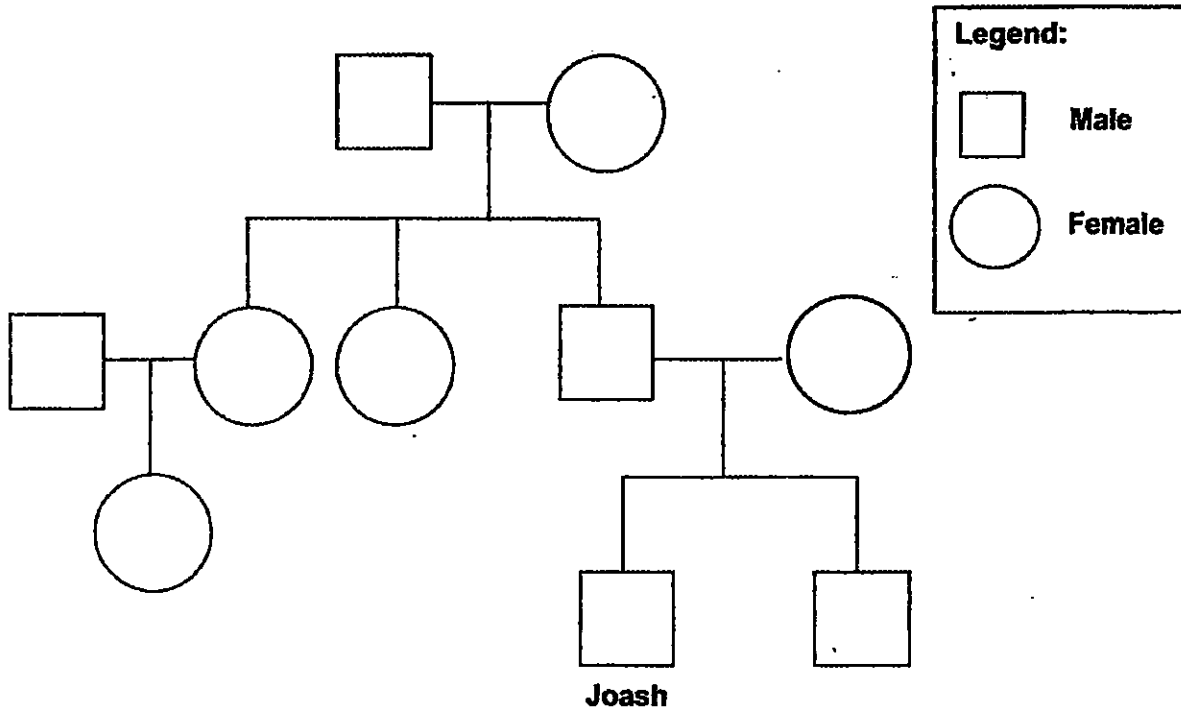

**Legend:**

□ Male

○ Female

Family member	Natural hair colour
Paternal grandfather	brown
Paternal grandmother	brown
Father	black
Mother	brown
Joash	black
Joash's brother	brown

(a) How many children do Joash's grandparents have? (1m)

\_\_\_\_\_

(b) From whom did Joash inherit his black hair? Explain your answer. (1m)

\_\_\_\_\_

\_\_\_\_\_

(c) In the family tree above, shade the symbol that represents Joash's mother. (1m)

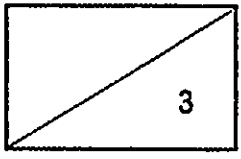



37. Sally set up two different electrical circuits, A and B, using identical light bulbs and batteries. Each circuit had two batteries. She measured the brightness of the light bulbs as she added more light bulbs to each circuit.

Based on the readings recorded, Sally plotted the graphs as shown below to compare the brightness of the bulbs in the two circuits.

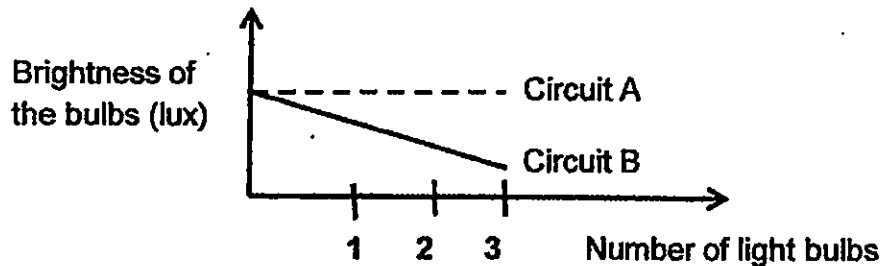

- (a) Identify the type of arrangement of bulbs for circuit A and B respectively. (1m)

Circuit A: \_\_\_\_\_

Circuit B: \_\_\_\_\_

- (b) Name one advantage for the arrangement of bulbs in circuit A. Explain why? (1m)

---

---

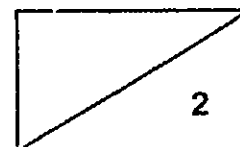

38. The diagram below shows a typical terrarium where plants are enclosed in a container made of clear glass. It is sealed with a glass lid. The terrarium is placed in the classroom. After sometime, some water droplets were observed in the container as shown.

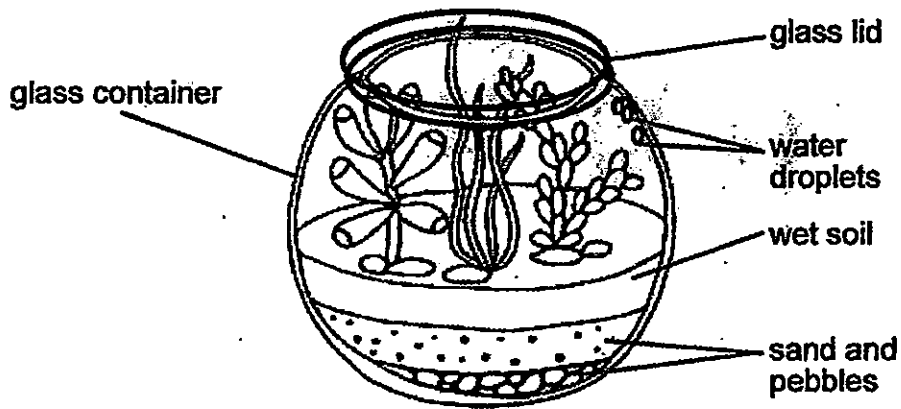

- (a) Explain how the water droplets were formed. (2m)

---

---

---

---

- (b) Between a closed cupboard and the living room balcony, where should one place the terrarium to ensure that the plants in it will grow healthily? Explain your answer. (1m)

---

---

- (c) How does the glass lid help to maintain the amount of water in the terrarium? (1m)

---

---

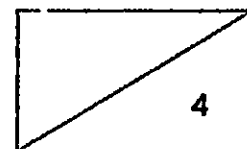

39. At 1pm, Ray hung some wet towels on a bamboo pole and put it out to dry as shown in diagram 1 below.

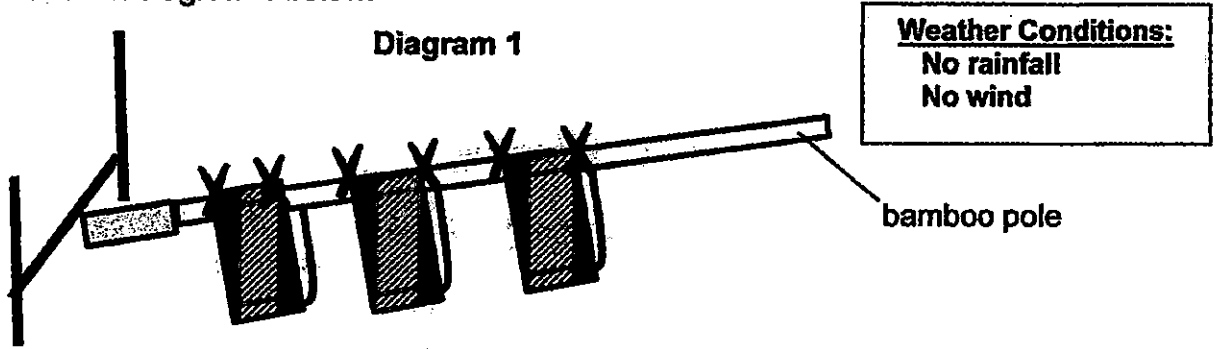

Ten minutes later, Ray's grandmother took the bamboo pole in and spread the towels out as shown in diagram 2. Then, she put the bamboo pole out again. She said that this would allow the towels to dry in a shorter time.

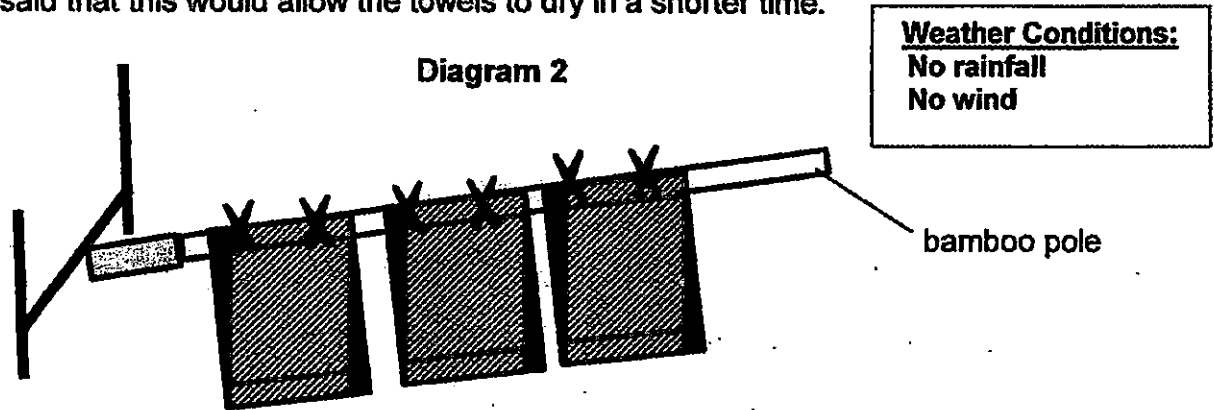

- (a) Explain why the change made by Ray's grandmother helped the towels to dry in a shorter time. (1m)

---

---

- (b) Given the same weather conditions as stated, hanging the towels out to dry in the day allows them to dry in a shorter time as compared to at night. Why is this so? (1m)

---

---

- (c) Besides the change made by Ray's grandmother and your answer in part (b), name one other factor which allows the towels to dry in a shorter time. (1m)

---

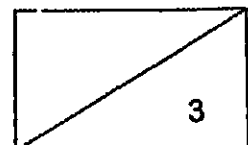

40. Look at the following diagrams. Gaelan wanted to make strawberry flavoured ice cubes.

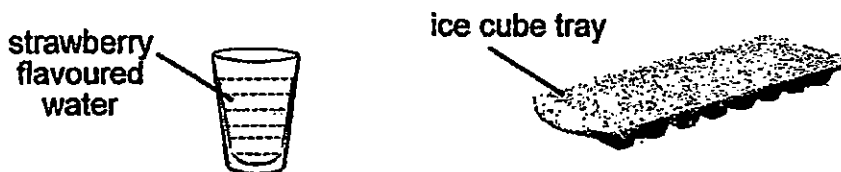

He poured the strawberry flavoured water into the ice cube tray. The tray was left in the freezer for one day.

- (a) Identify the state of matter for the following. (1m)

(i) strawberry flavoured water in the glass: \_\_\_\_\_

(ii) strawberry flavoured water in the ice cube tray after five hours : \_\_\_\_\_

In another separate experiment, Gaelan inverted 2 similar glass cups, A and B, vertically into a basin of water at the same time as shown. He observed that water filled up cup A totally but not cup B.

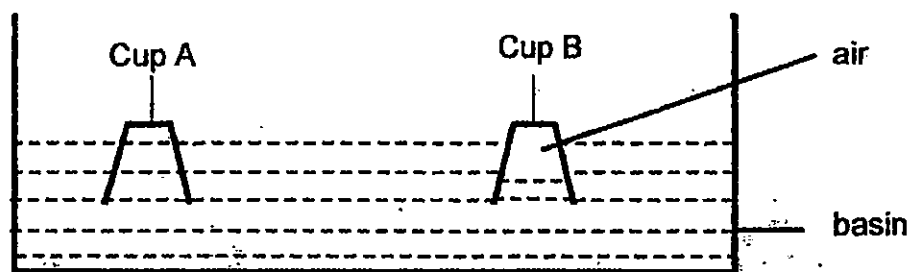

- (b) Suggest what could be different about Cup A that caused the water level to be different as compared to Cup B. (1m)

\_\_\_\_\_

- (c) Explain why less water entered cup B. (1m)

\_\_\_\_\_  
\_\_\_\_\_

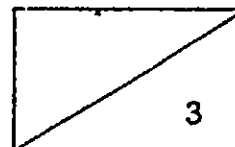

41. The diagrams show 3 objects of the same height of 10 cm and width of 3 cm. They are placed in front of a screen. They are a pencil, a container and a ruler made of wood. A light source was switched on and the shadows of the objects were cast on the screen.

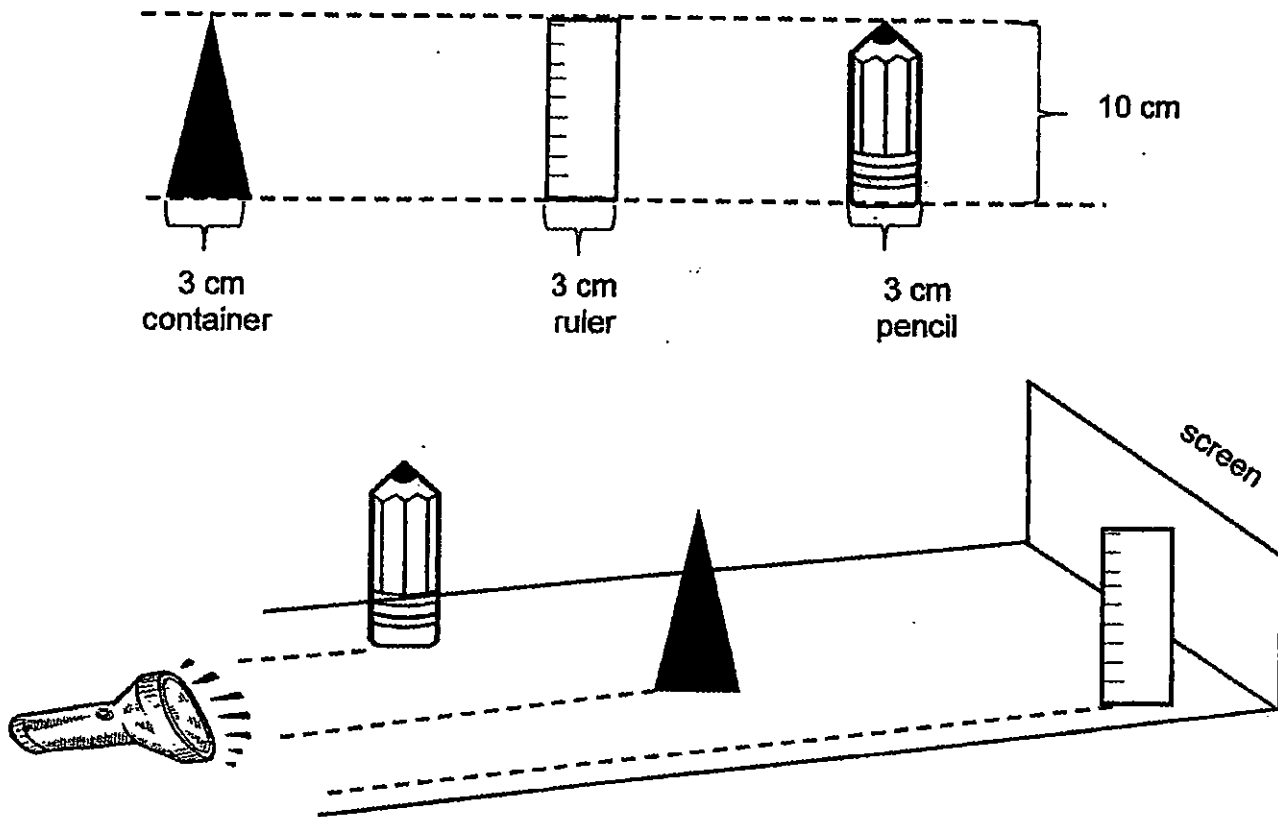

- (a) Tick, (✓), the correct set of shadows cast on the screen by the three objects. (1m)

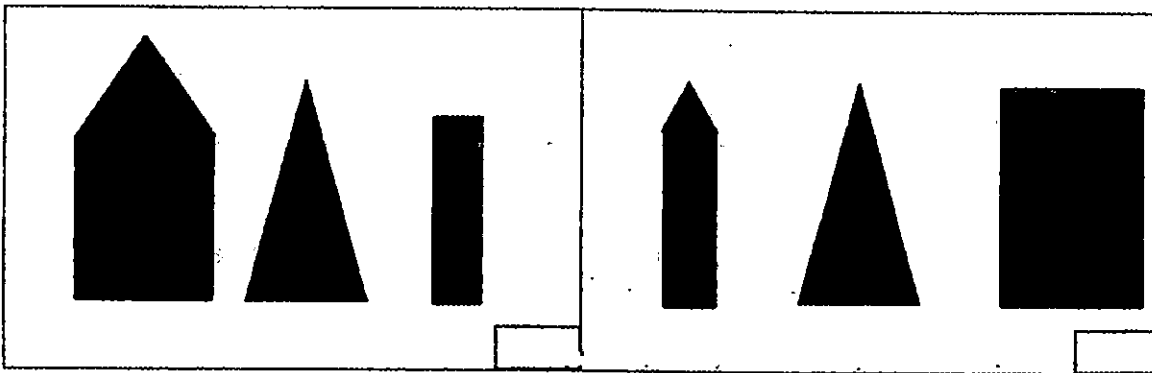

- (b) How does the distance of an object from the light source affect the length of its shadow? (1m)

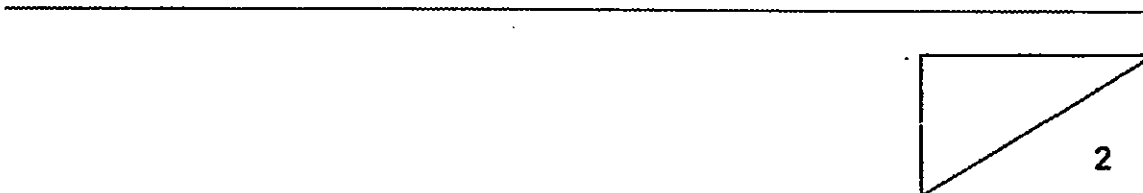

42. Jerald had three containers made of three different materials, X, Y and Z. He recorded the temperature of the water in the three containers after water at  $80^{\circ}\text{C}$  was poured into them and tabulated the results in the table below.

	Material X	Material Y	Material Z
Temperature of water in the cup after 30 minutes ( $^{\circ}\text{C}$ )	70	30	40

Next, he designed a cup sleeve as illustrated below for a cup. Jerald was able to hold the cup of hot coffee for a longer time with the cup sleeve.

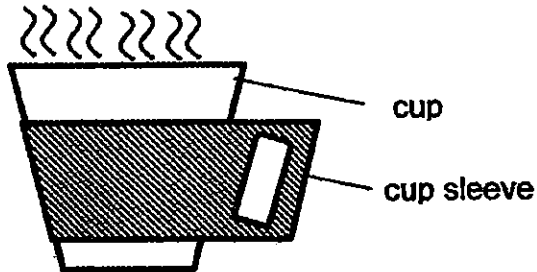

- (a) Among the three materials, X, Y or Z, which is the best choice for making the cup sleeve? Explain your choice. (2m)

---



---



---

- (b) Jerald made a cup of hot coffee at  $70^{\circ}\text{C}$  and left it on a table in the living room. Then, he used a thermometer to measure the change in the temperature of the coffee over a period of three hours. He drew a graph as shown below.

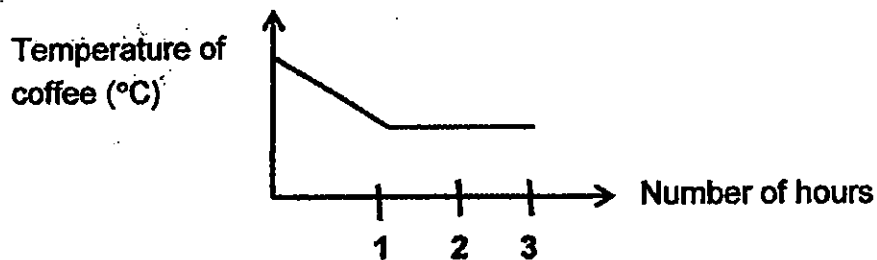

The temperature of the room was  $30^{\circ}\text{C}$ . Jerald found that the temperature of the coffee was also  $30^{\circ}\text{C}$  after three hours. Why was it so? (1m)

---



---

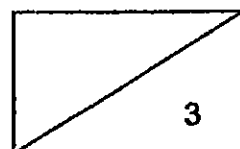

43. Study the diagram carefully. Nadia gave the soccer ball a hard kick at part R as shown. The ball moved towards part S and landed at part T.

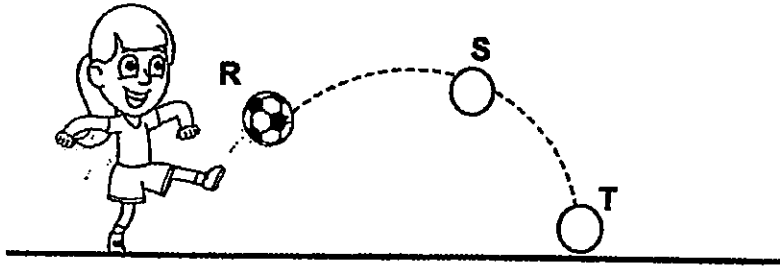

- (a) Identify one force which acted on the ball at part S. (1m)

---

Nadia conducted an experiment in the Science room. She pushed two similar soccer balls across a glass surface and a sandpaper surface with the same amount of force. The distance moved by each ball was recorded in the table shown.

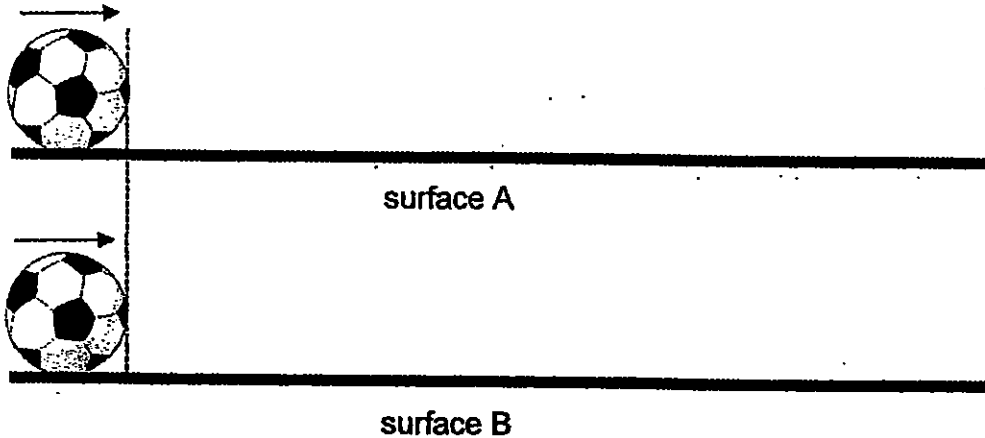

	Distance moved by the soccer ball (cm)		
	1 <sup>st</sup> try	2 <sup>nd</sup> try	Average
Surface A	30	32	31
Surface B	15	17	16

- (b) Which surface, A or B, was the glass surface? Explain why. (1m)

---



---

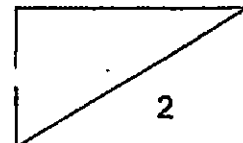

44. Sulin saw a toy at a shop. This toy moved up and down continuously with a push as shown below. It did not require any battery for it to move. The toy beetles and the identical parts labelled A were not in contact at all times.

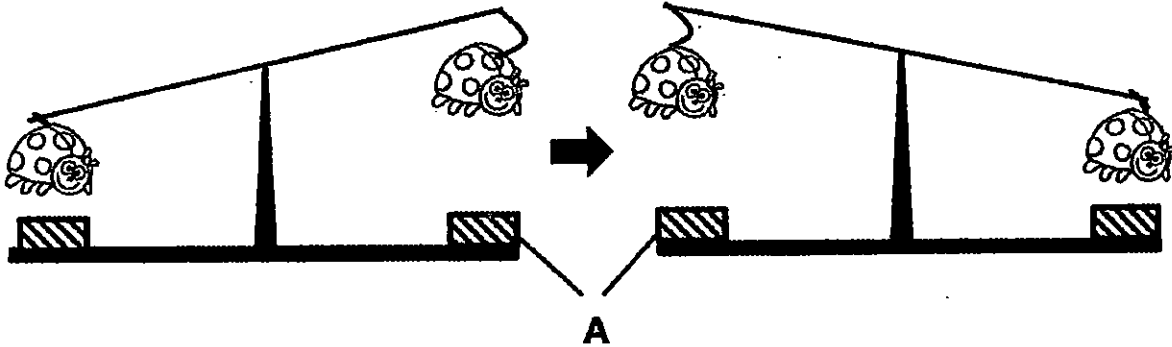

When she tried to push the toy beetle down towards part A, she could feel a force pushing it upwards. Her mother pointed out that there were two forces acting on the toy to make it move.

- (a) Name one force that acted on the toy beetle to allow it to move continuously. (1m)

---

- (b) Explain why, in terms of forces, the toy could move continuously after Sulin gave it a push. (2m)

---

---

---

---

**End of Section B**  
**Please check your answers.**

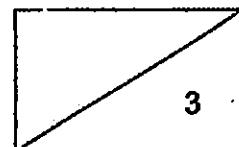





**EXAM PAPER 2015**

**LEVEL : PRIMARY 5**  
**SCHOOL : RED SWASTIKA SCHOOL**  
**SUBJECT : SCIENCE**  
**TERM : SA2**

Q1	Q2	Q3	Q4	Q5	Q6	Q7	Q8	Q9	Q10
3	4	1	3	3	3	2	2	4	3
Q11	Q12	Q13	Q14	Q15	Q16	Q17	Q18	Q19	Q20
3	4	4	1	2	3	3	2	1	2
Q21	Q22	Q23	Q24	Q25	Q26	Q27	Q28	Q29	Q30
4	1	2	1	1	2	1	1	4	4

Q31a. C has less than 3 body parts and has 8 legs. Q31b. D

Q31c. **SEE PICTURE** Q31d. Beaker T.

Step	Procedure
1	Pour 500 ml of water into each beaker, S and T.
4	Place both beakers in a sunny field for a week.
5	Observe and count the number of plant(s) W that remained alive after one week.
2	Put 5 water plant W into each beaker, S and T.
3	Add 10 drops of pollutant Y into beaker S.

Q32a. The higher the temperature, the higher the rate of photosynthesis of plant Z.

Q32b. The roots of plant Z absorbed the water in the test tube for photosynthesis.

Q33a. Limewater turns chalky when carbon dioxide touches it. Animal X breathed out carbon dioxide and the carbon dioxide went through the delivery tube, thus turning the limewater chalky.

Q33b. A has more oxygen than B. The amount of oxygen in the blood at A has not been used yet but the amount of oxygen at B was less than A as the body has used up most of the oxygen so the amount of oxygen at A is more than B.

Q34a. Each of them has a nucleus.

Q34b.i) Cell S Q34bii) Cell T

Q34c. Cell S can photosynthesize but cell T cannot.

Q35a. Part X: ovule Q35b. Part Y: Petal

Q35b. Fruit A. There are more than one ovule in flower Z and fruit A has more than one seed.

Q36a. 3 Q36b. Joash's father. His father has black father so Joash inherited his black hair from his father.

Q36c. **SEE PICTURE**

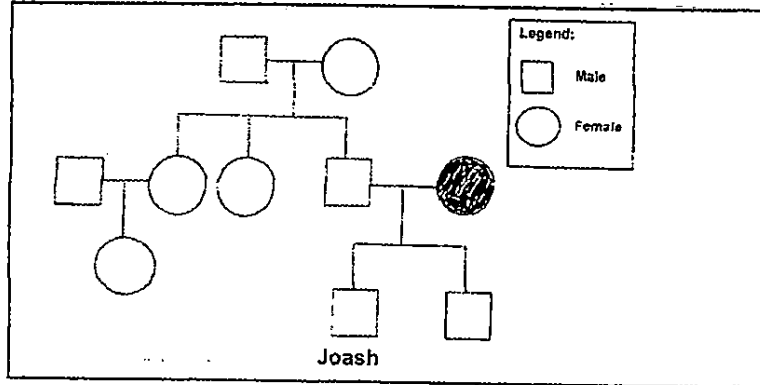

Q37a. Circuit A : parallel Circuit B : series

Q37b. If one bulb fuses, the other will still light up. There is another closed circuit so electricity can still flow through the circuit.

Q38a. The water in the wet soil gained heat and evaporated into water vapor. The warm water vapor then came into contact with the cooler surface of the glass container and condensed into water droplets.

Q38b. Living room balcony. The plants need light to photosynthesize to make food so if it is in a closed cupboard, the plant will starve.

Q38c. It prevents water vapor from escaping.

Q39a. There was more exposed surface area so the towels would dry in a shorter time.

Q39b. The temperature was higher in the day than at night so the towel will dry quicker in the day.

Q39c. No model answer.

Q40ai) Liquid Q40aii) solid

Q40b. There was a hole in cup A.

Q40c. The air in cup B occupies space so less water can enter cup B.

Q41a. SEE PICTURE

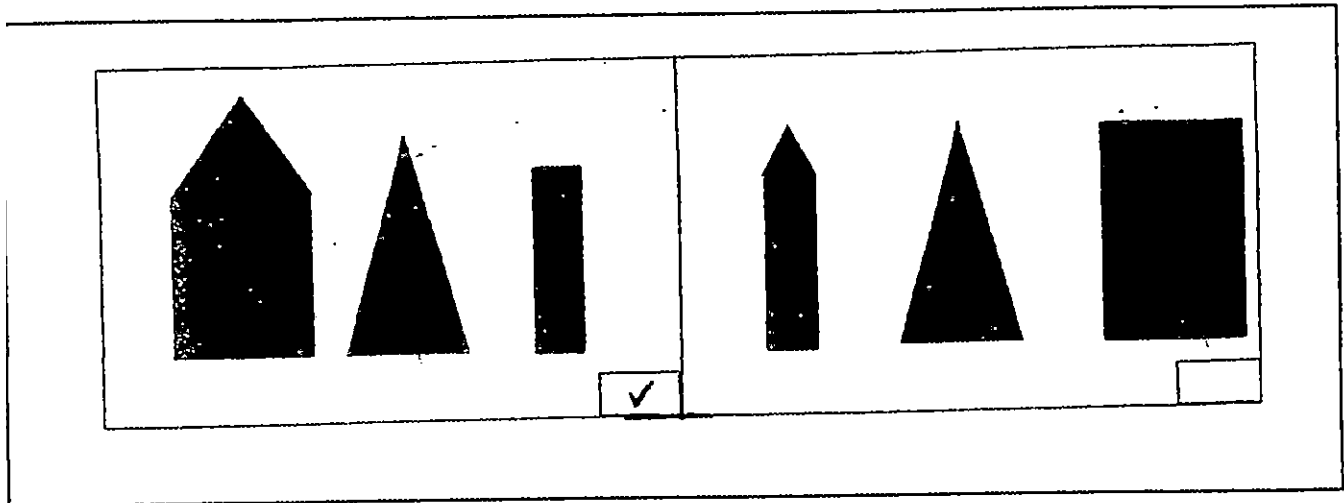

Q41b. The nearer the distance of an object from the light source, the longer the length of the shadow.

Q42a. Material X. Material X is the poorest conductor of heat so it would take the longest time to conduct heat.

Q42b. The coffee lost heat to the surroundings and stopped when it reached room temperature.

Q43a. Gravitational force

Q43b. Surface A. Glass is a smooth surface so there will be less friction between the soccer ball and surface.

Q44a. Magnetic force.

Q44b. There was a magnetic force of repulsion acting on the toy beetle.

**THE END**