



PRIMARY 3 MID-YEAR EXAMINATION 2017

Name : _____

Date: 8 May 2017

Class : Primary 3 ()

Duration: 1 hour

Marks: _____ / **28**

SCIENCE BOOKLET A

INSTRUCTIONS TO CANDIDATES

Write your name, register number and class.

Do not turn over this page until you are told to do so.

Follow all instructions carefully.

Answer all questions.

Shade your answers in the Optical Answer Sheet (OAS) provided.

Section A (14 × 2 marks= 28 marks)

For each question, 1 to 14, choose the most suitable answer and shade its corresponding oval (1, 2, 3 or 4) in the optical answer sheet.

- 1 The diagram below shows how some things are classified based on the characteristics, X and Y.

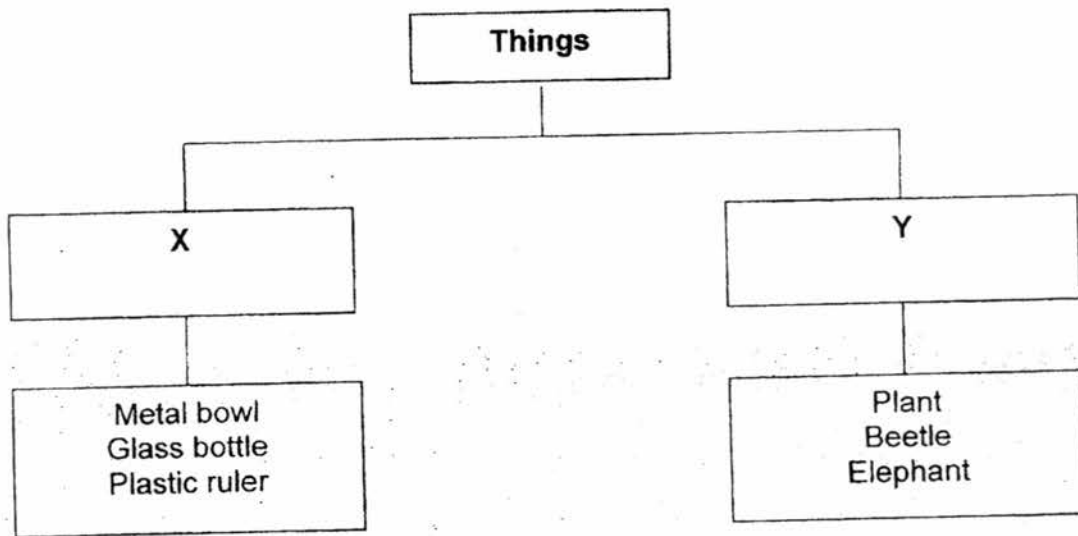

Which of the following correctly describes the characteristics, X and Y?

	X	Y
(1)	Can grow	Cannot grow
(2)	Cannot reproduce	Can reproduce
(3)	Cannot make its own food	Can make its own food
(4)	Can respond to changes in the environment	Cannot respond to changes in the environment

2. Mei Ling placed 2 grasshoppers in 2 different glass containers as shown in the diagram below.

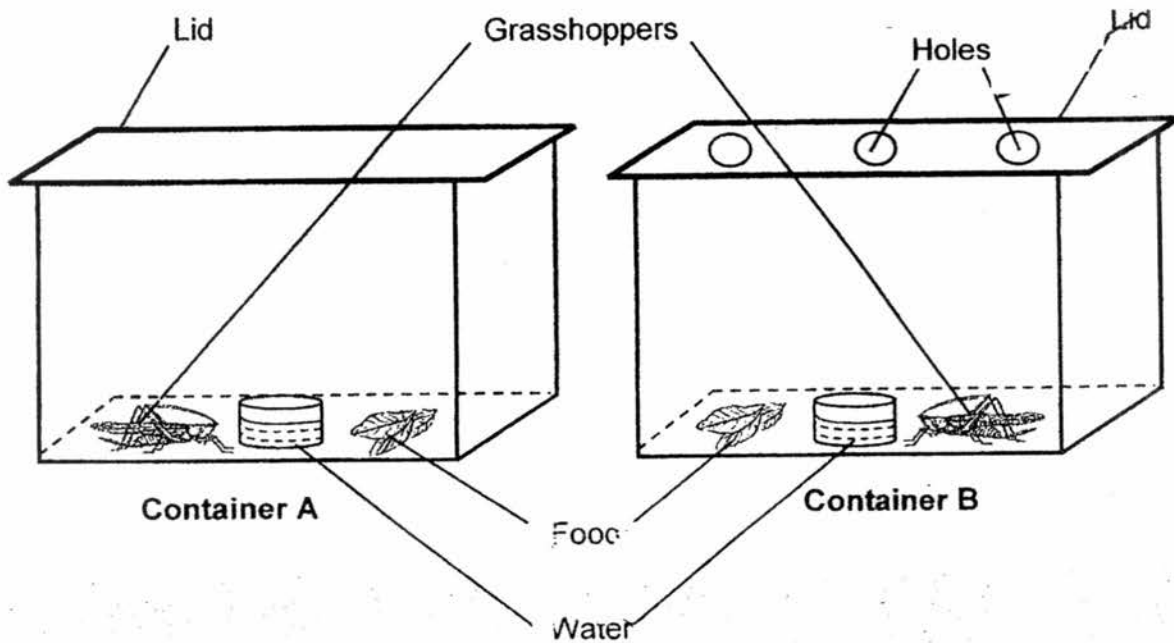

After 3 days, Mei Ling discovered that the grasshopper in Container A had died while the grasshopper in Container B was still alive. What does this experiment show about living things?

- (1) Living things need air to survive.
 - (2) Living things need food to survive.
 - (3) Living things need light to survive.
 - (4) Living things need water to survive
3. Which of the following statements about flowering plants is true?
- (1) All flowering plants live on land.
 - (2) Flowering plants do not bear fruits.
 - (3) Flowering plants reproduce by seeds.
 - (4) Flowering plants reproduce by spores.

4. Below are Organism X and Organism Y.



Organism X

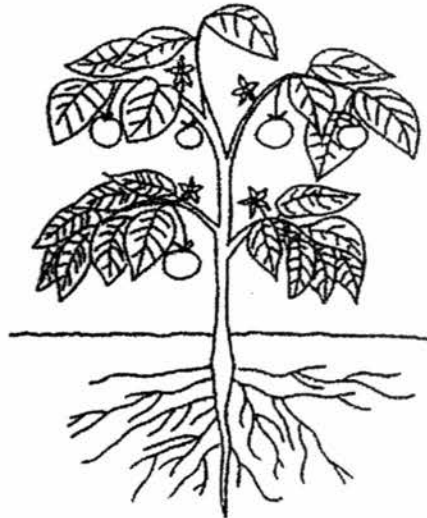

Organism Y

Which of the following statements describes Organism X and Organism Y?

- (1) Both can make food.
- (2) Both reproduce by spores.
- (3) Both need water to survive.
- (4) Both need sunlight to make food.

5. Tom classified some animals into 2 groups as shown below.

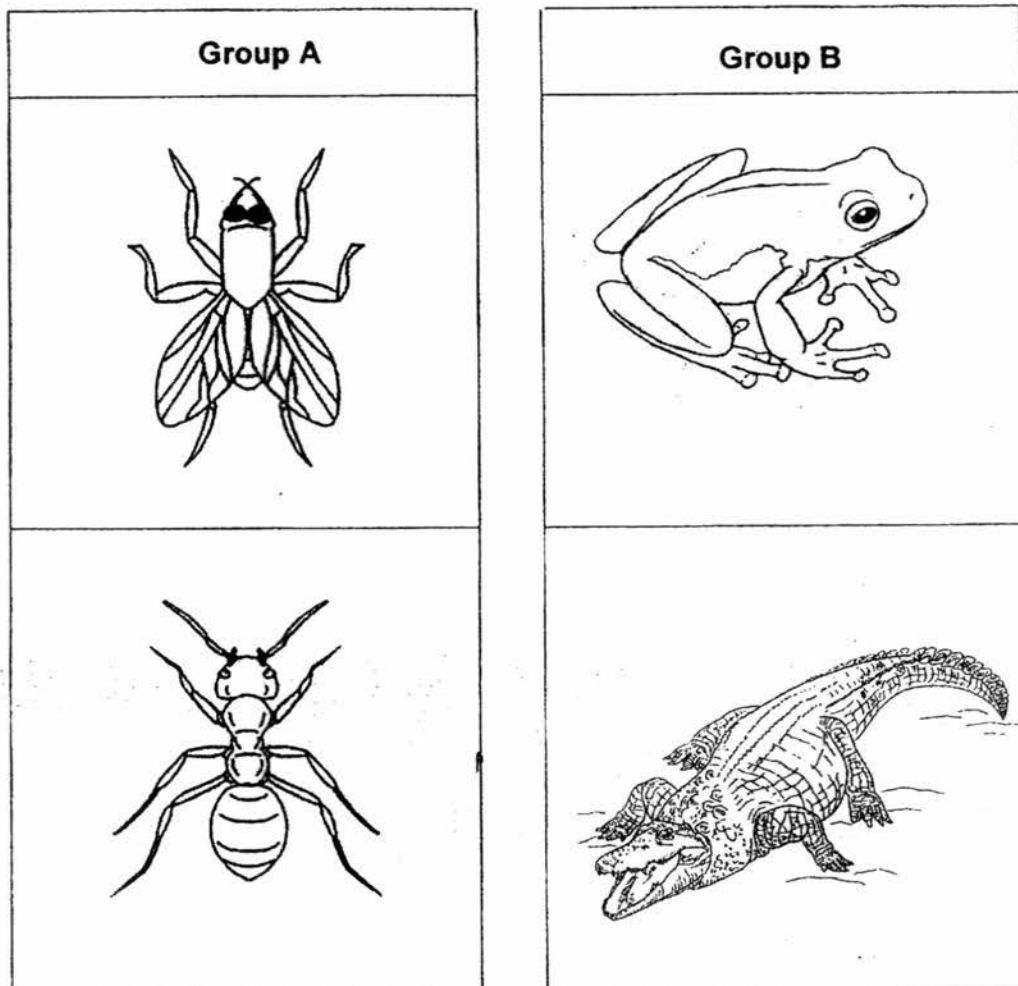

Which characteristic did Tom use to classify the animals?

- (1) Number of legs
- (2) Number of wings
- (3) Presence of eyes
- (4) Presence of beak

6. Some characteristics of Animal X, Animal Y and Animal Z are listed in the table below.

Characteristics	Animal X	Animal Y	Animal Z
Breathes through gills		✓	
Has scales as outer covering		✓	
Gives birth to young alive			✓
Has moist skin	✓		
Lays eggs	✓	✓	
Has hair on its body			✓

Which of the following are represented by Animal X, Animal Y and Animal Z?

	Animal X	Animal Y	Animal Z
(1)	Frog	Dog	Crocodile
(2)	Goldfish	Crocodile	Dog
(3)	Dog	Goldfish	Frog
(4)	Frog	Goldfish	Dog

7. Look at the picture below.

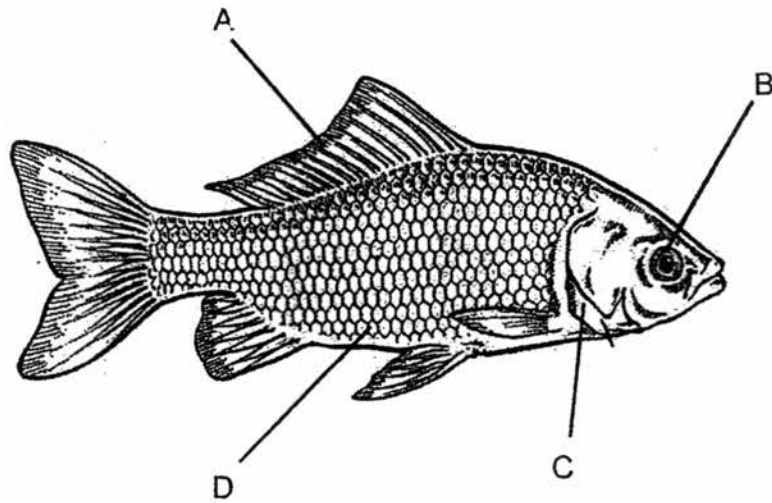

Based on the picture above, which labelled part allows the fish to breathe?

- (1) A
 - (2) B
 - (3) C
 - (4) D
8. Look at the picture of a snake below.

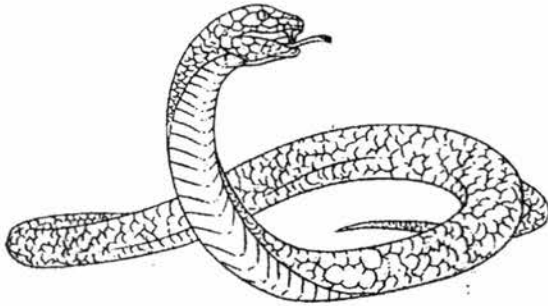

Based on the picture above, which of the following statements is definitely true?

- (1) It has scales.
- (2) It breathes through gills.
- (3) It gives birth to its young
- (4) It feeds its young with milk.

9. Which of the following statements about bacteria are true?

A: Bacteria can be harmful.

B: Bacteria are non-living things.

C: Bacteria are micro-organisms.

D: Bacteria can be found in our bodies.

(1) A and B only

(2) C and D only

(3) A, C and D only

(4) A, B, C and D

10. Siti put 4 slices of bread in identical plastic bags as shown below.

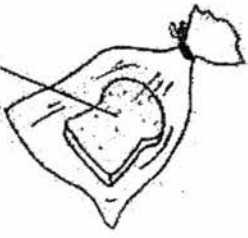
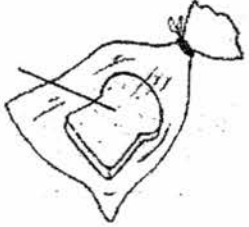
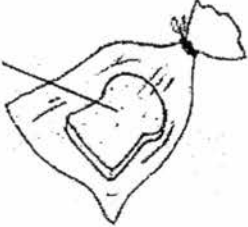
Set-up A	Set-up B
<p data-bbox="367 442 502 487">Dry bread</p>  <p data-bbox="430 680 710 714">Put in a Refrigerator</p>	<p data-bbox="837 442 973 487">Wet bread</p>  <p data-bbox="917 691 1197 725">Put in a Refrigerator</p>
Set-up C	Set-up D
<p data-bbox="375 884 510 929">Dry bread</p>  <p data-bbox="391 1134 758 1168">Put in a Wooden Cupboard</p>	<p data-bbox="837 884 973 929">Wet bread</p>  <p data-bbox="869 1134 1236 1168">Put in a Wooden Cupboard</p>

Which set-up would be the first to have fungi growing on its bread?

- (1) Set-up A
- (2) Set-up B
- (3) Set-up C
- (4) Set-up D

11. The drawing below shows a pair of spectacles and a shoe.

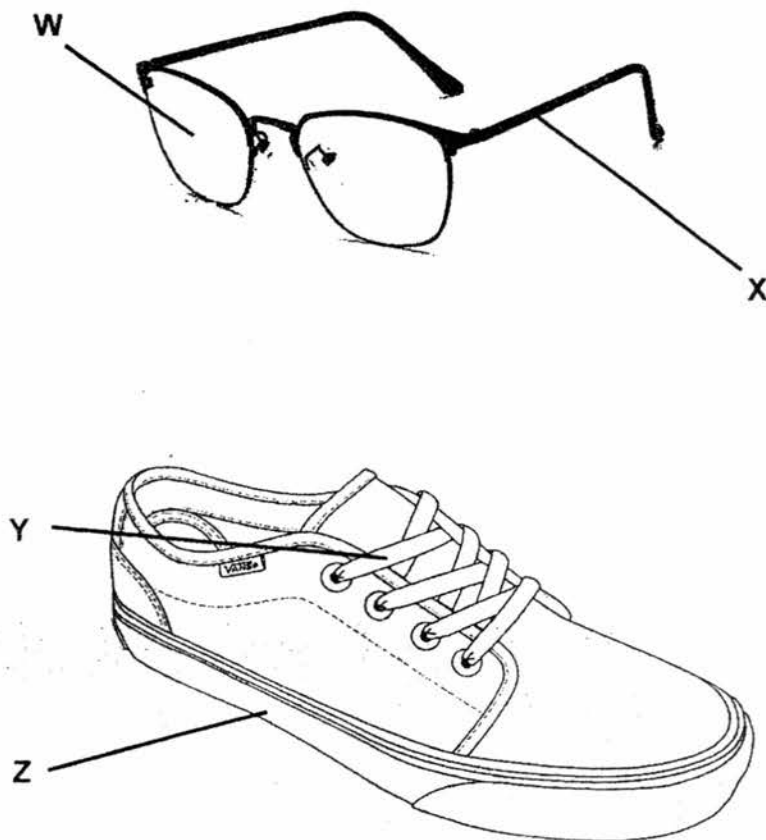

Which materials are most suitable to make the parts W, X, Y and Z?

	W	X	Y	Z
(1)	Metal	Metal	Rubber	Fabric
(2)	Plastic	Metal	Fabric	Rubber
(3)	Metal	Plastic	Fabric	Rubber
(4)	Plastic	Metal	Rubber	Fabric

12. Study the flow chart below. A, B and C represent objects made of different materials.

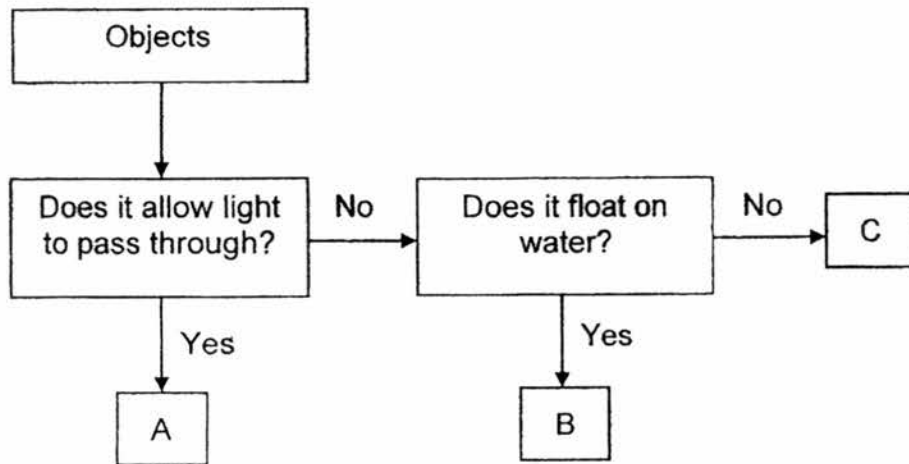

Which of the following shows what A, B and C most likely represent?

	A	B	C
(1)	Magnifying glass	Metal Coin	Rubber band
(2)	Rubber band	Wooden chopsticks	Metal Coin
(3)	Metal Coin	Rubber band	Magnifying glass
(4)	Glass window	Wooden chopsticks	Metal Coin

13. Kumar wanted to compare the strength of four materials, R, S, T and U. He dropped a 1kg object from a height of 2m onto the material as shown below. The materials were of the same size, thickness and shape.

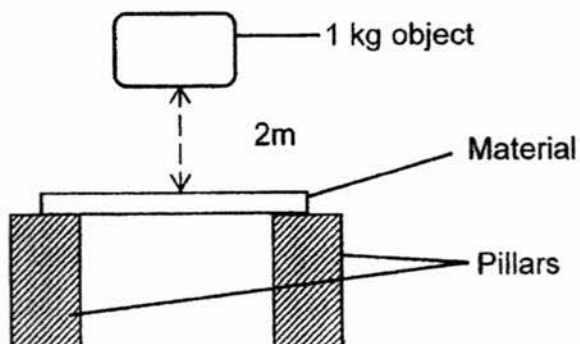

He noted the number of times the 1kg object was dropped before the material broke. His results are shown below.

Material	Number of times the 1kg object was dropped before the material broke
R	40
S	25
T	55
U	18

Based on the results above, which of the following conclusions is correct?

- (1) Material T is the weakest material.
- (2) Material U is the strongest material.
- (3) Material T is weaker than Material S.
- (4) Material R is stronger than Material U.

14. Study the classification chart below. A, B, C and D are materials.

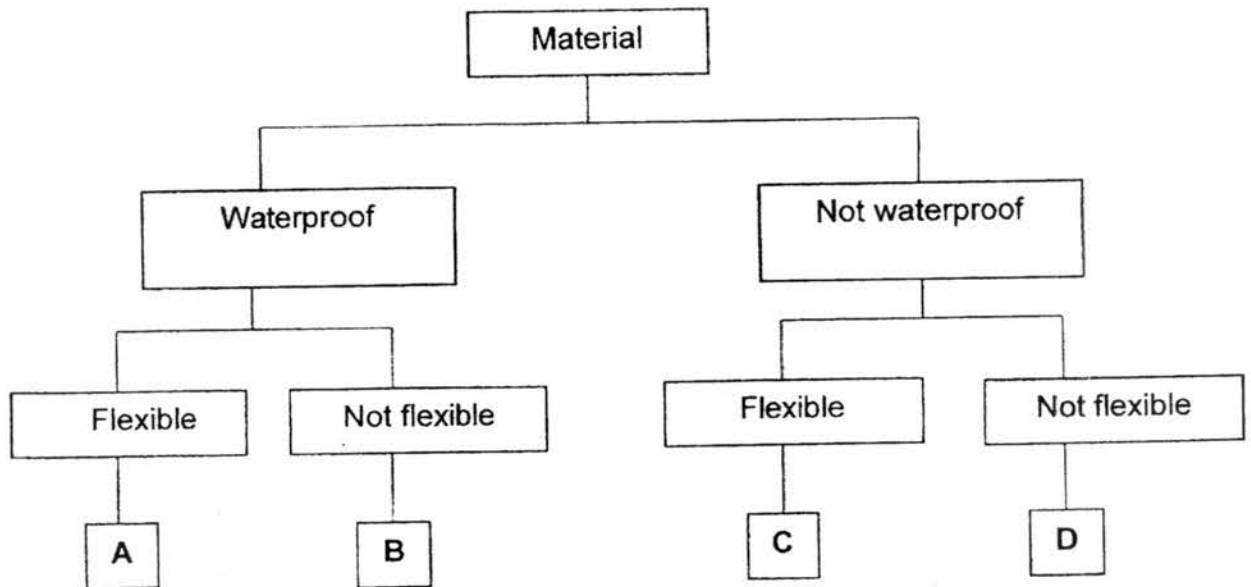

Based on the classification chart given, which material, A, B, C or D is most suitable for making part X of the tap shown below?

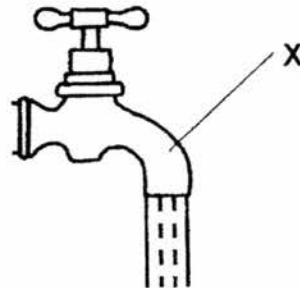

- (1) A
- (2) B
- (3) C
- (4) D

– End of Booklet A –



PRIMARY 3 MID-YEAR EXAMINATION 2017

Name _____

Date: 8 May 2017

Class : Primary 3 () .

Duration: 1 hour

Marks: _____ / 2.

SCIENCE BOOKLET B

INSTRUCTIONS TO CANDIDATES

Write your name, register number and class.

Do not turn over this page until you are told to do so.

Follow all instructions carefully.

Answer all questions.

Write your answers in this booklet.

Section B (22 marks)

For the questions, 15 to 24, write your answers in the spaces provided.

15. Study the things below.

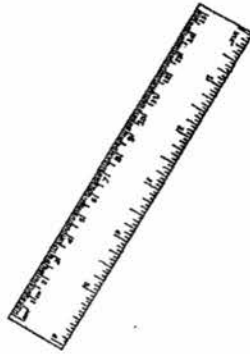

Ruler



Teddy Bear



Dead Leaves



Butterfly

(a) Which of the above is a living thing?

(1m)

(b) Give a reason for your choice in (a).

(1m)

16. Mark conducted the following experiment on his pet earthworm. He set up a tank as shown below.

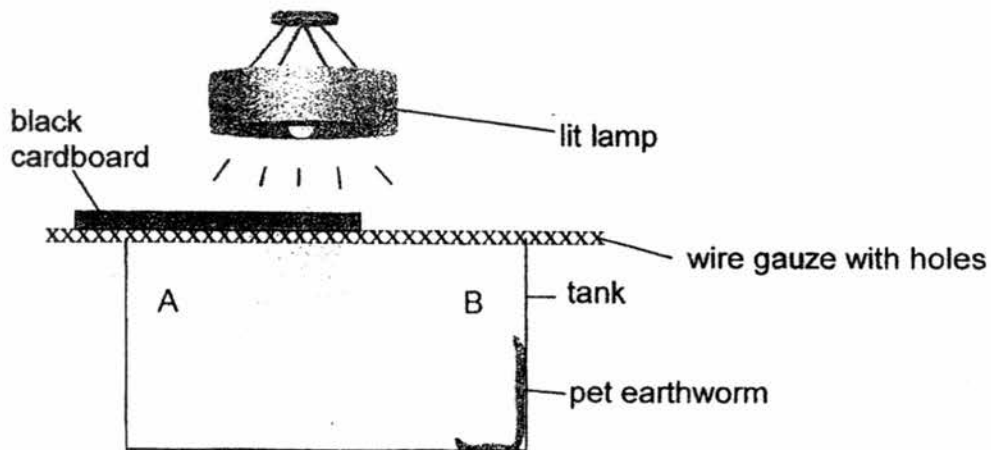

He placed his earthworm on side B of the tank and shone light over the earthworm. He observed the behaviour of his pet earthworm for five minutes. The earthworm moved towards side A, the covered side of the tank. He did the experiment 10 times. Each time, the earthworm moved towards side A.

- (a) Mark then slid the black cardboard over to side B. Predict what his earthworm would do. (1m)

- (b) State a characteristic of living things shown in this experiment. (1m)

17. The pictures below show Plant A and Plant B.

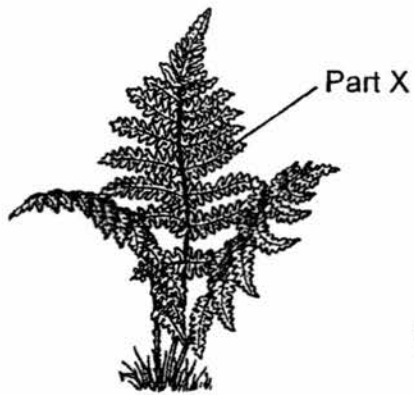

Plant A



Plant B

(a) State one function of Part X and Part Y of the plants above. (1m)

(b) Based on the pictures above, state one difference between Plant A and Plant B. (1m)

18. Name the plant parts marked A, B, C and D in the diagram below. (2m)

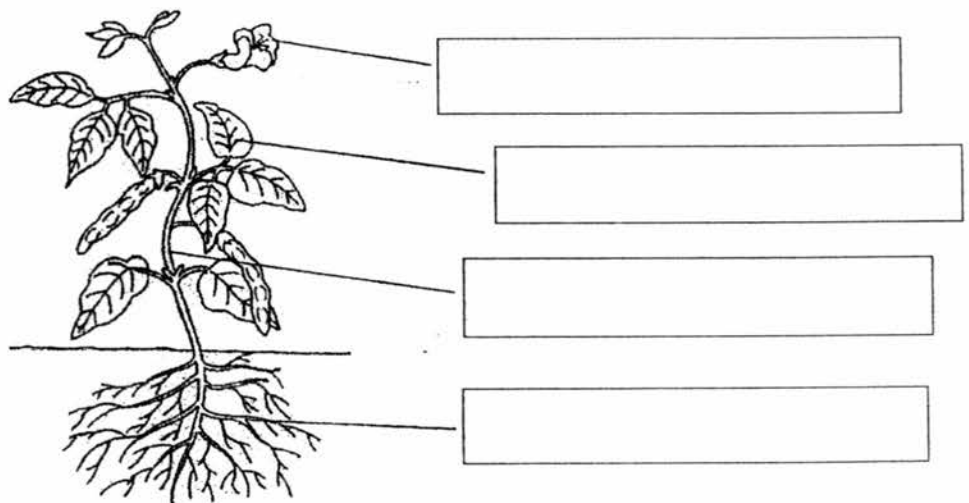

19. Study the diagram of some plants in a pond as shown below.

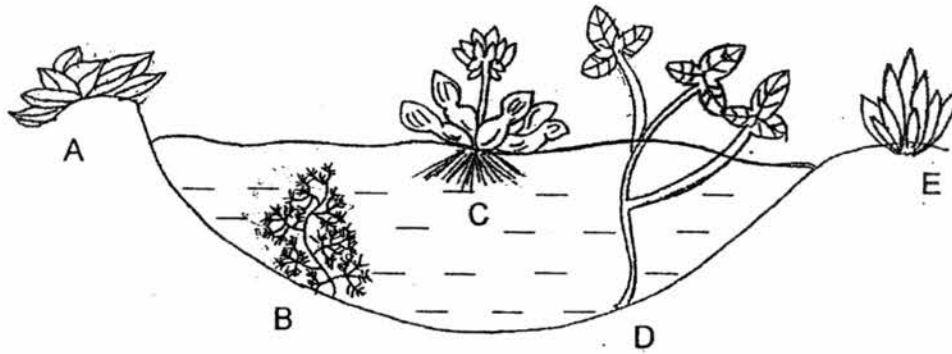

- (a) In the table below, the plants have been classified according to where they live. Give the headings (i) and (ii) of the two groups of plants in the boxes provided. (1m)

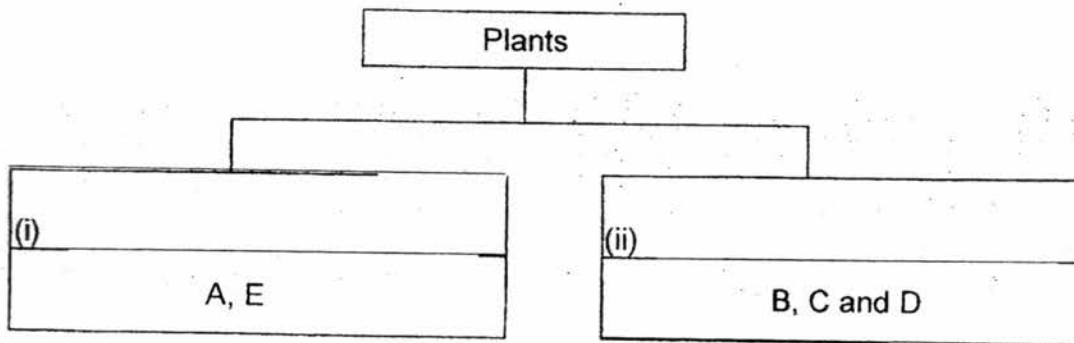

- (b) Can a Papaya Tree be grouped together with the plants B, C and D? Explain your answer. (1m)

20 Danny classified six animals into two groups as shown below.

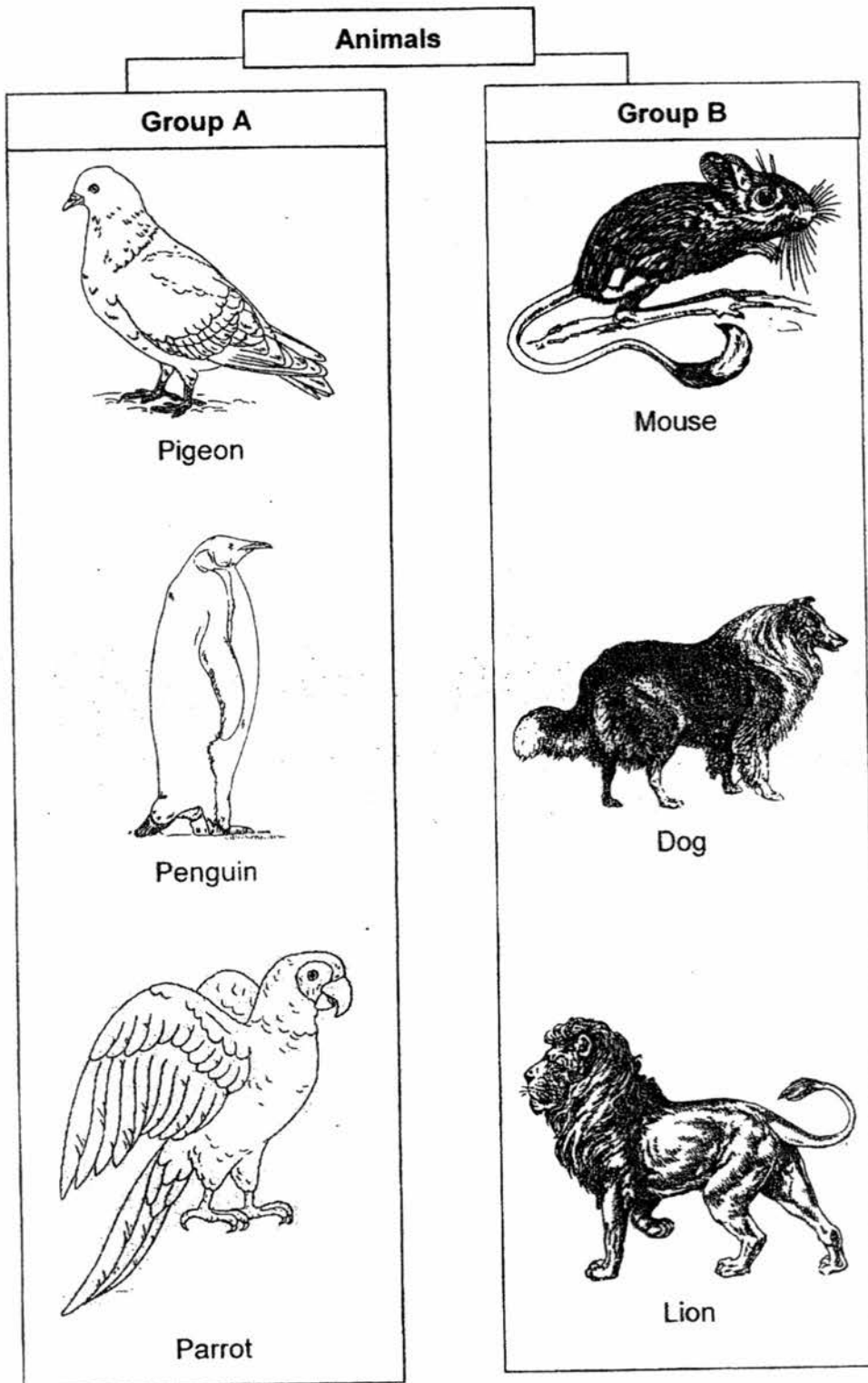

- (a) State two differences in the characteristics of the animals in Group A and Group B. (2m)

Difference 1: _____

Difference 2: _____

- (b) The picture below shows an ostrich.

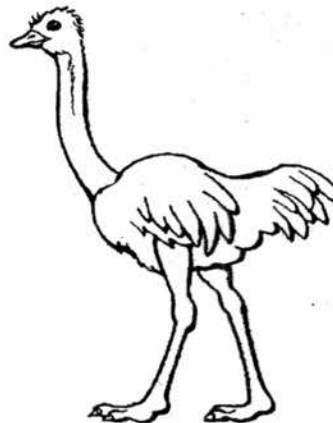

In Group A or Group B should Danny place the ostrich in? Based on the observable characteristics of the ostrich, give a reason for your answer. (1m)

21. Study the animals below.

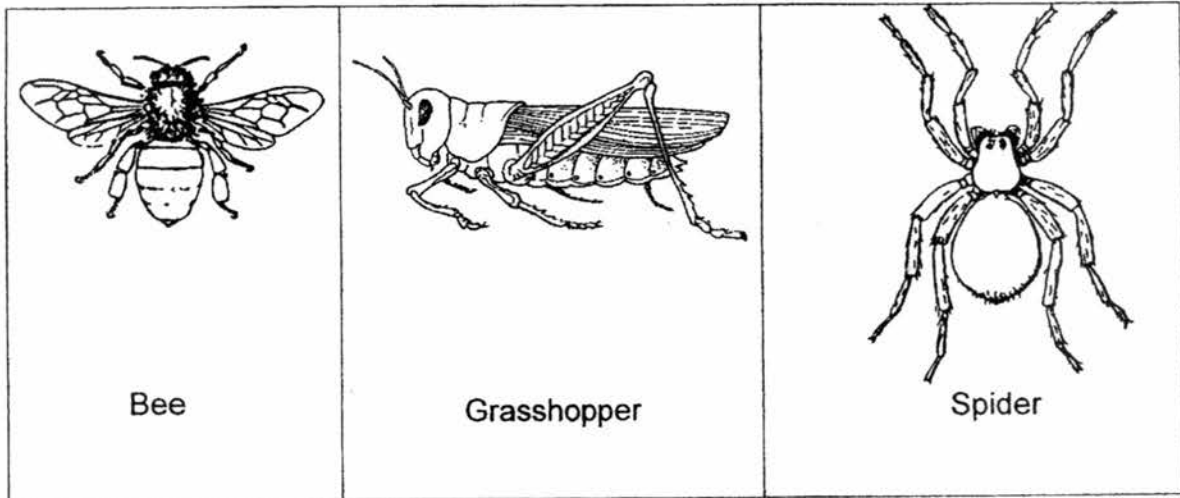

(a) Which of the animals shown above is not an insect? (1m)

(b) Based on the diagrams above, give two reasons why it is not an insect. (2m)

Reason 1: _____

Reason 2: _____

22. Xuan Xuan conducted an experiment to find out how water affected the growth of fungi. She put different amounts of water on three pieces of leather. She then observed the amount of fungi growing on them. The table below shows her observation.

Amount of water (ml)	Amount of fungi
2	small patch
4	medium patch
6	large patch

- (a) What happened to the amount of fungi when more water was added onto the leather? (1m)

- (b) Besides air and water, state another condition needed for the fungi to grow on the leather (1m)

23. Study the flowchart below. X and Y are materials.

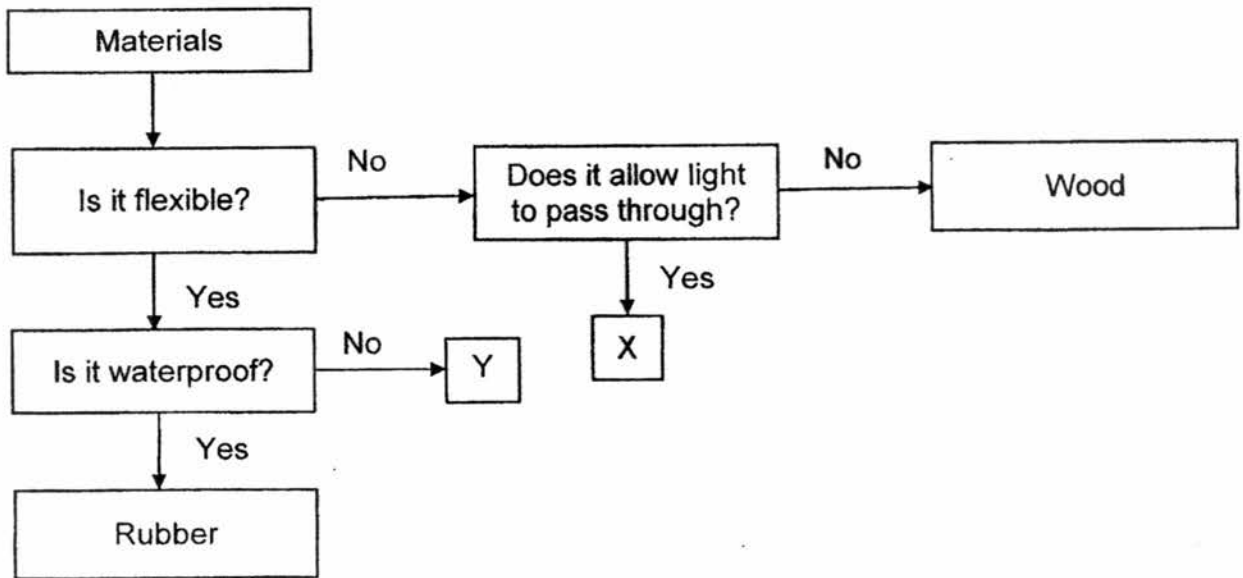

(a) Based on the flowchart above, state all the characteristics of Material Y.

(1m)

(b) Give the name of the material that can be represented by X.

(1m)

24. Nura wants to choose a suitable material to make a swimming float. After dropping Materials A and B into a tank of water, her observation is as shown below.

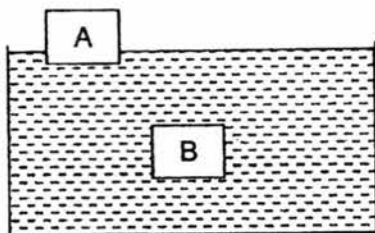

When she places a 5 kg weight on each material, she observes what happens as shown below.

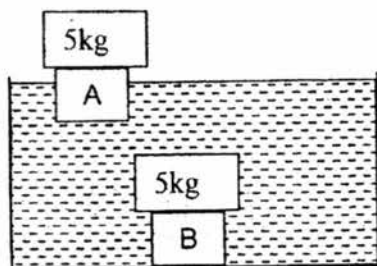

- (a) Nura concludes that Materials A and B are suitable for making swimming floats. Do you agree with her? Give a reason for your answer. (1m)

- (b) State another property a material must have in order to be used to make a swimming float. (1m)

– End of Paper –

EXAM PAPER 2017

LEVEL : PRIMARY 3
SCHOOL : TAO NAN PRIMARY SCHOOL
SUBJECT : SCIENCE
TERM : MID-YEAR EXAM

BOOKLET A
Section A

Q1	Q2	Q3	Q4	Q5	Q6	Q7
2	1	3	3	1	4	3
Q8	Q9	Q10	Q11	Q12	Q13	Q14
1	3	4	2	4	4	2

BOOKLET B
Section B

- Q15. (a) **The butterfly is a living thing.**
(b) **It can respond to changes.**
- Q16. (a) **The earthworm would move to side B.**
(b) **Living things can respond to changes.**
- Q17. (a) **Part X and Part Y takes in air so the plant can make its own food.**
(b) **Plant B is a flowering plant where as plant A is not.**
- Q18. A. flower
B. leave
C. stem
D. roots
- Q19. (a) (i) **lives on land**
(ii) **lives in water**
(b) **No. A papaya tree only grows on land if it take in too much water it would die.**

Qn	Suggested Answer/Answers	Reflection
15	(a) A butterfly. (b) A butterfly can reproduce but the dead leaves, ruler and teddy bear cannot.	<input checked="" type="checkbox"/> I compared
16	(a) The earthworm will move to side B. (b) Living things respond to changes	
17	(a) Both parts make food for the plants. (b) Plant A is a non-flowering plant but Plant B is a flowering plant.	<input checked="" type="checkbox"/> I compared
18	A: Flower B: Leaf C: Stem D: Root	
19.	(a) (i) land plants (ii) water plants (b) No. The papaya tree is a land plant but Plants B, C and D are water plants.	
20.	(a) Difference 1: Animals in Group A have feathers while animals in Group B have hairs. Difference 2: Animals in Group A have beaks while the animals in Group B do not have/have mouths (b) Group A. The ostrich has wings just like the animals in Group A.	<input checked="" type="checkbox"/> I compared clearly <input checked="" type="checkbox"/> I compared clearly <input checked="" type="checkbox"/> I compared

Q20. (a) Difference 1: The animals in Group A has feathers but the animals in group B have hair.

Difference 2: The animals in Group A has wings but the animals in Group B does not.

(b) Group A. It has a beak and feathers like all the other animals in Group A.

Q21. (a) The spider is not an insect.

(b) Reason 1: It has eight legs and insect only has 6 legs.

Reason 2: It only has 2 body parts and insects has 3 body parts.

Q22. (a) The fungi grows even more.

(b) Fungi also need a warm environment.

Q23. (a) It is flexible but not waterproof.

(b) It could be glass.

Q24. (a) I do not agree with her. Material B sinks to the bottom of the fish tank when she adds a five kg weight into it. The person using it will drown.

(b) It must be waterproof.