



## PRIMARY 5 END-OF-YEAR EXAMINATION 2011

Name: \_\_\_\_\_ (      ) Date: 31 October 2011

Class : Primary 5 (      )

Time: 8.00 a.m. - 9.25 a.m.

Parent's Signature : \_\_\_\_\_

Marks: \_\_\_\_\_ / 40

# SCIENCE BOOKLET A

### INSTRUCTIONS TO CANDIDATES

Write your name, class and register number.

Do not turn over this page until you are told to do so.

Follow all instructions carefully.

Answer all questions.

**Section A (20 x 2 marks)**

For each question from 1 to 20, four options are given. One of them is the correct answer. Make your choice (1, 2, 3 or 4). Shade the correct oval, (1, 2, 3 or 4) on the Optical Answer Sheet.

- 1) Risa observed two different cells, **Cell A** and **Cell B**, as shown below.

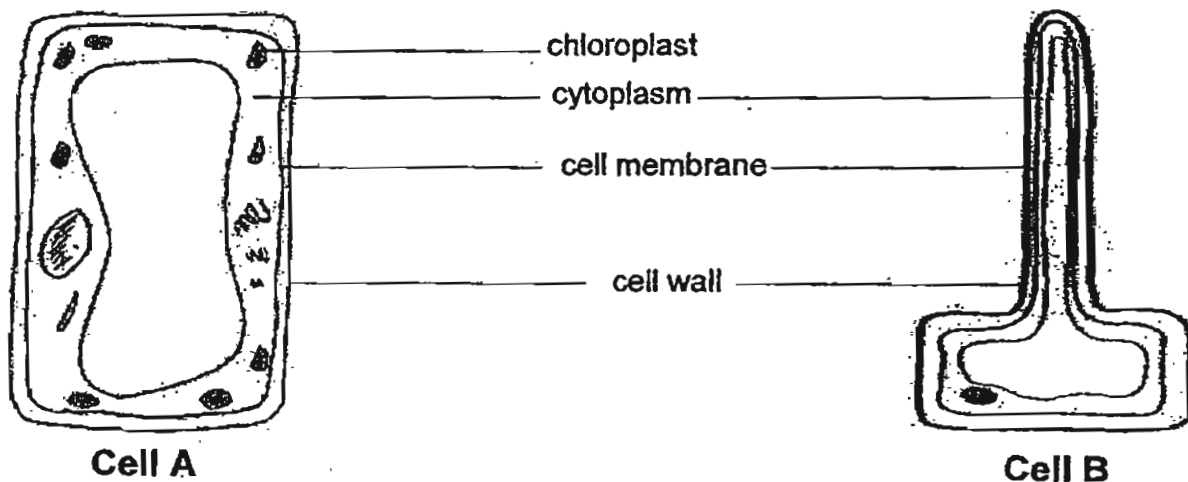

Which of the following best explains the difference in their cell parts?

- (1) Cell A is a plant cell while Cell B is an animal cell.
- (2) Cell A supports the plant upright while Cell B does not.
- (3) Cell A has a big vacuole while Cell B has a small vacuole.
- (4) Cell A is found in the leaves while Cell B is found in the roots.

2) Which of the following shows the correct reproductive cycle of a flowering plant?

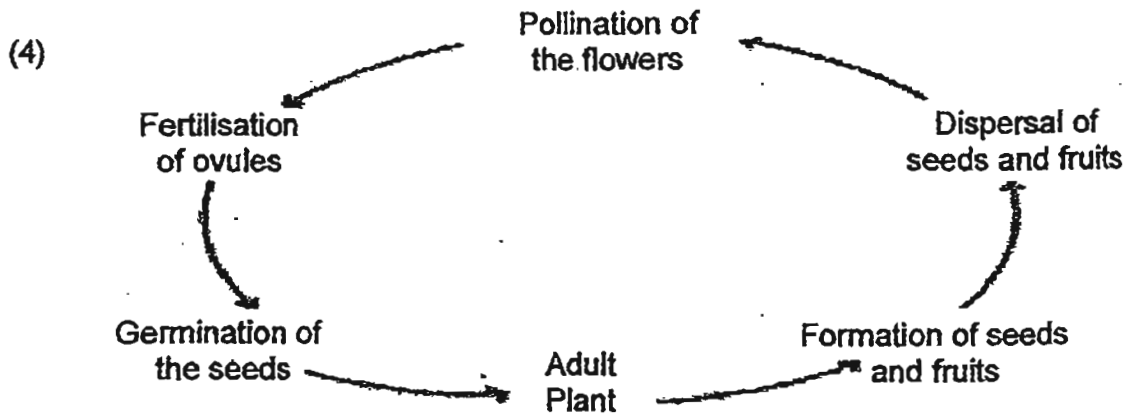
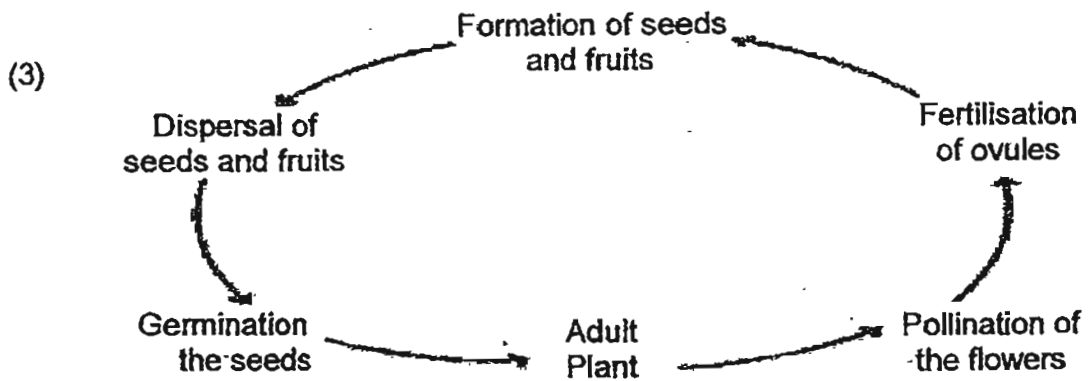
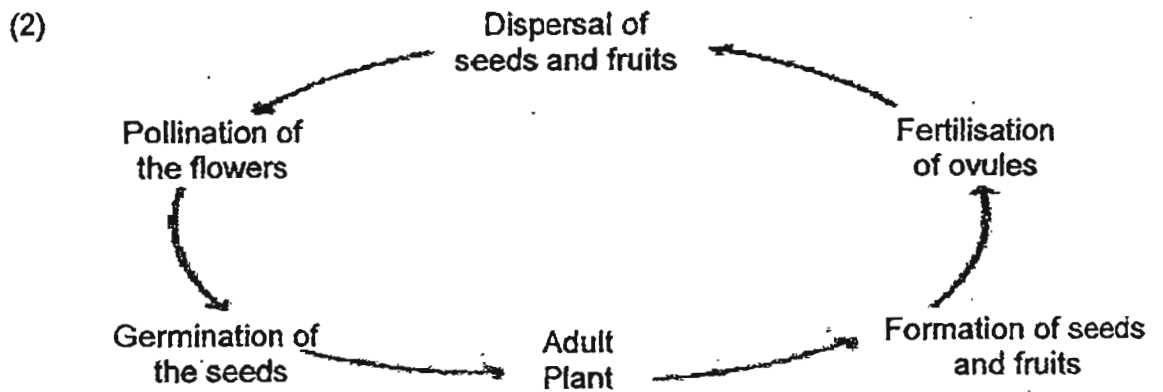
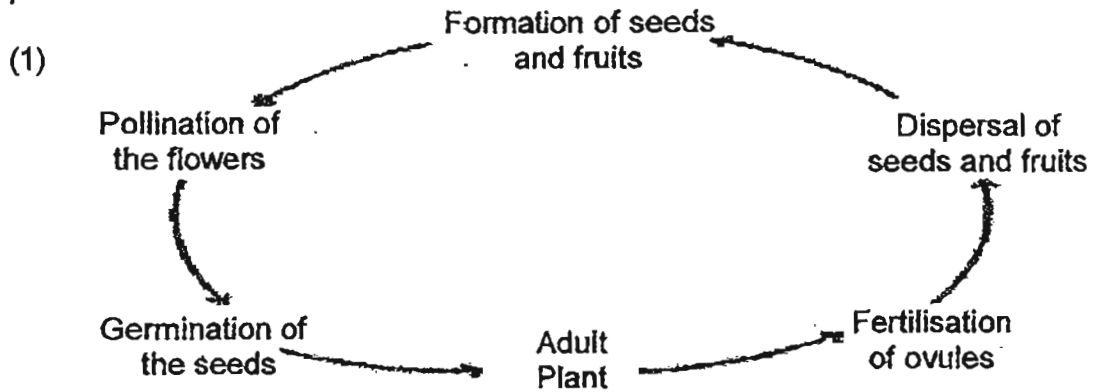

3) Four organisms, P, Q, R and S, are classified according to the chart below.

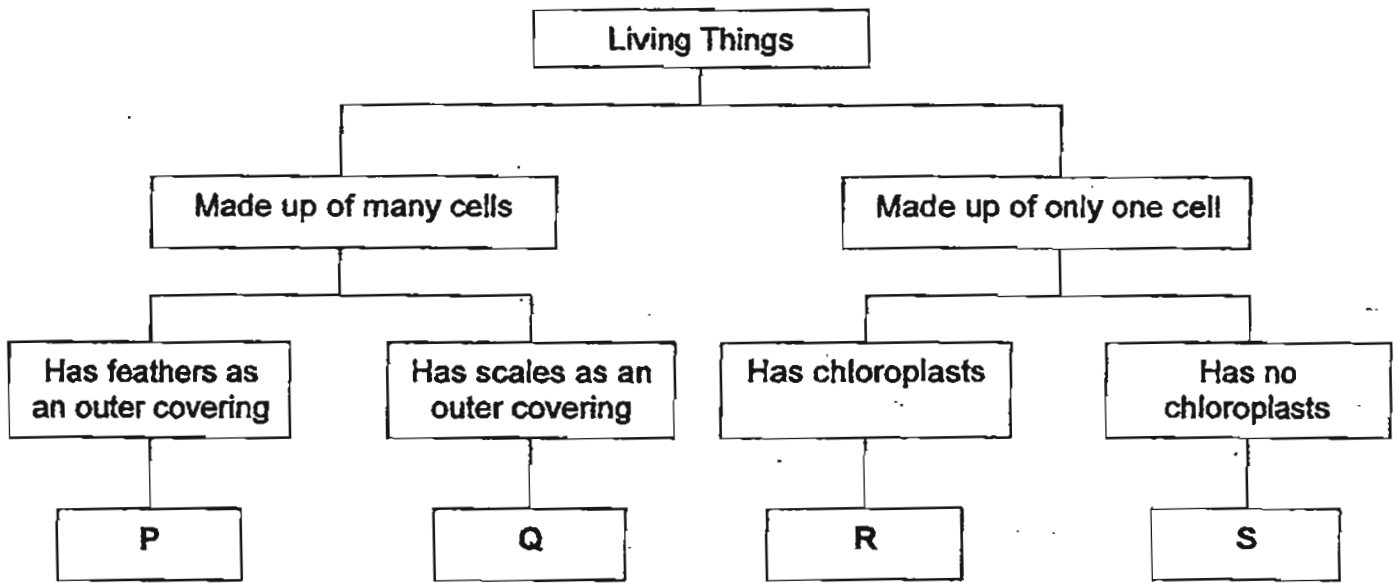

Based on the chart, which of the following is true?

- (1) Q is an animal while R is a plant.
- (2) S is a root cell while R is a leaf cell.
- (3) R can make food while S cannot make food.
- (4) P could be a penguin while Q could be a whale.

4) The flowchart below can be used to identify some flowering plants.

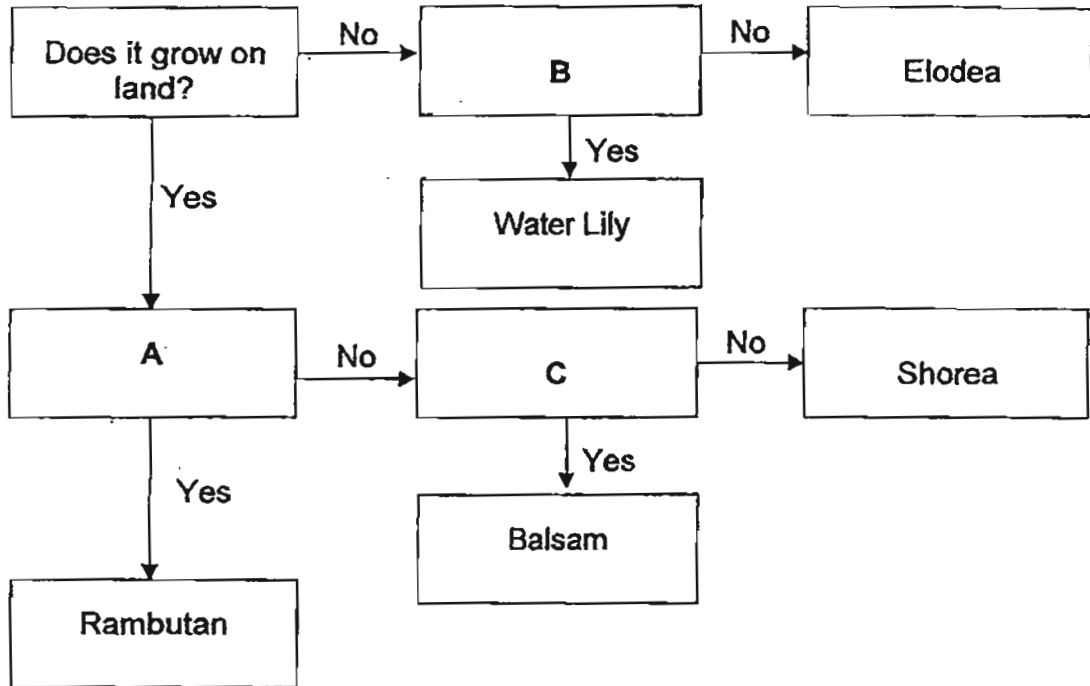

What do A, B and C in the flowchart represent?

	A	B	C
(1)	Does the fruit have stiff hair?	Is it fully submerged in water?	Is the fruit or seed dispersed by explosive action?
(2)	Is the fruit or seed dispersed by animals?	Does it bear flowers that are above the water surface?	Does the fruit have a fruit wall that splits open forcefully when ripe?
(3)	Is the fruit edible?	Does the fruit have a fibrous husk?	Does the fruit have a wing-like structure?
(4)	Does the fruit have only one seed?	Does it have swollen leaf stalks?	Is the fruit covered with hooks?

- 5) The diagrams below show the reproductive system of a plant and a human.

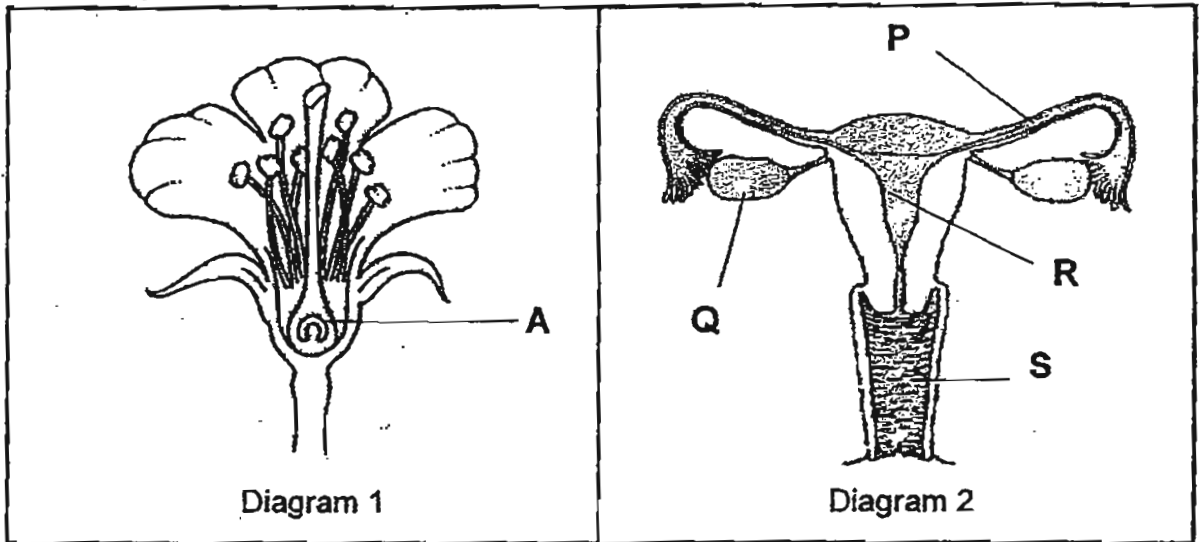

Which part, P, Q, R or S, in Diagram 2, has the same function as part A, in Diagram 1?

- (1) P
- (2) Q
- (3) R
- (4) S

- 6) The family tree of Timothy is shown below. It also shows the type of ear lobes that is passed on from his parents to their young.

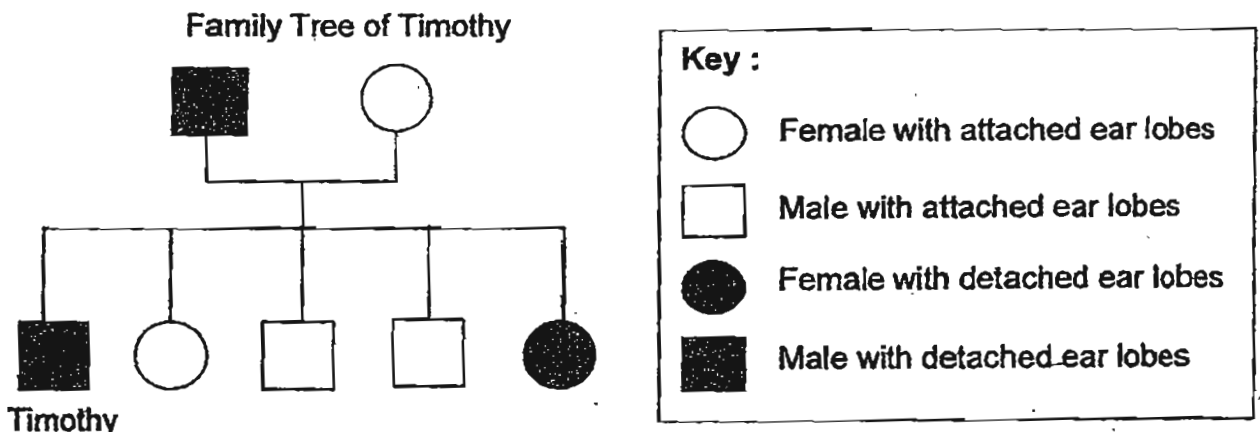

Which of the following about Timothy's family is true?

- 1) Most of Timothy's family members have detached ear lobes.
- 2) Timothy is the only son in the family with detached ear lobes.
- 3) Timothy has the same type of ear lobes as his younger sister.
- 4) Timothy's sisters have the same type of ear lobes as their mother.

- 7) The diagram below shows two identical beakers. Beaker A contains oil while Beaker B contains water. Both beakers are balanced evenly on a lever. The set-up was left under the sun.

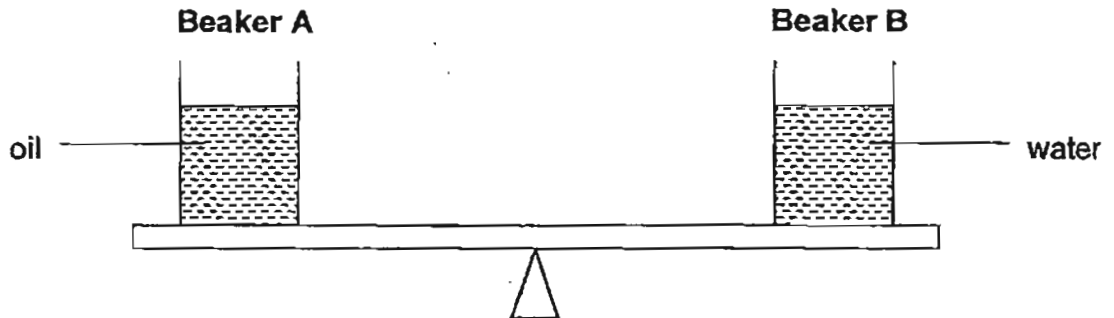

Which of the following will be observed after an hour?

- (1) The lever remains balanced.
  - (2) The lever will tilt downwards at Beaker A.
  - (3) There is lesser liquid left in Beaker A than in Beaker B.
  - (4) More liquid has evaporated from Beaker A than from Beaker B.
- 8) Matthew wants to investigate which material is more suitable for making a cup which keeps drinks cold. The diagram below shows his set-up.

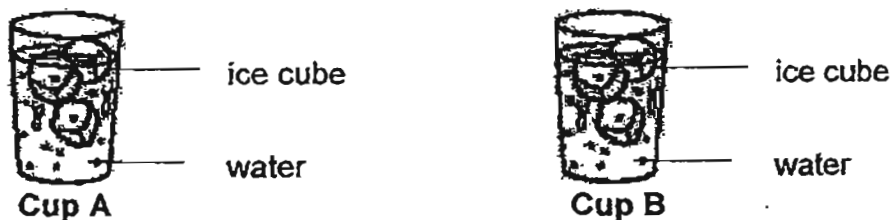

To ensure a fair test, which of the following should Matthew keep constant?

- (1) The amount of ice in each cup
- (2) The type of material used to make each cup
- (3) The number of water droplets on the sides of each cup
- (4) The time taken for all the ice cubes in each cup to melt

9) The diagram below shows a human respiratory system.

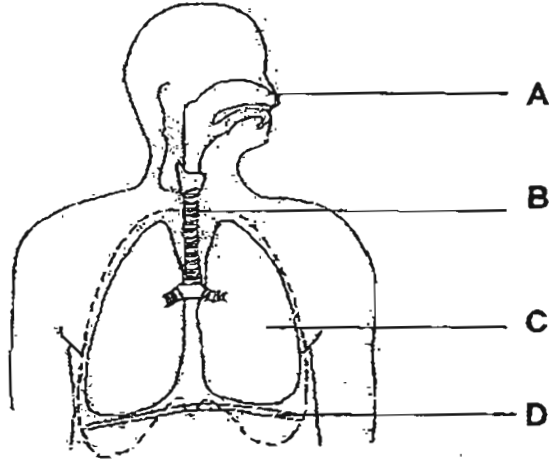

What happens when a person breathes in?

- (1) A will cleanse the air.
- (2) B will moisten the air.
- (3) C will deflate.
- (4) D will move upwards.

10) The graph below shows Annabel's pulse rate, immediately after different activities, A, B and C.

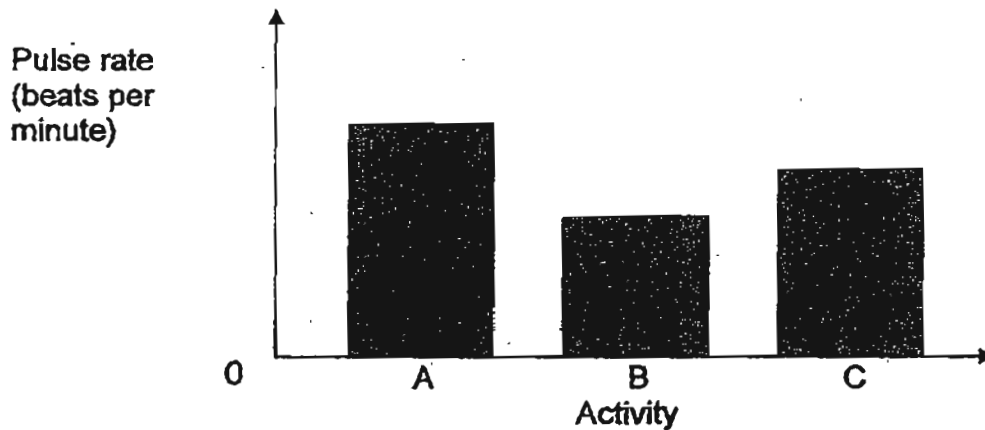

Which of the following represents the activities, A, B and C, before each pulse rate was obtained?

	A	B	C
(1)	Running	Eating	Walking
(2)	Sleeping	Jogging	Reading
(3)	Sprinting	Climbing	Resting
(4)	Walking	Reading	Sprinting



- 11) Joan set up an experiment as shown below. In the set-up, the container is sealed to prevent air from entering or leaving the container.

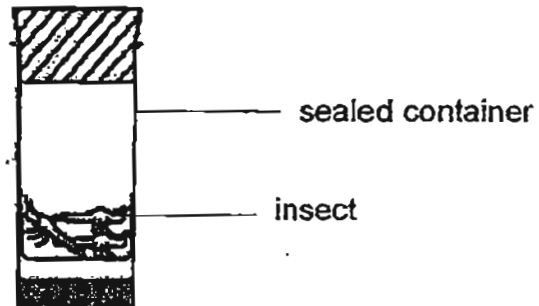

Which of the following gases would remain constant throughout the experiment?

- (1) Oxygen
  - (2) Nitrogen
  - (3) Water vapour
  - (4) Carbon dioxide
- 12) The diagram below shows how blood flows in a bear through 4 different blood vessels, A, B, C and D.

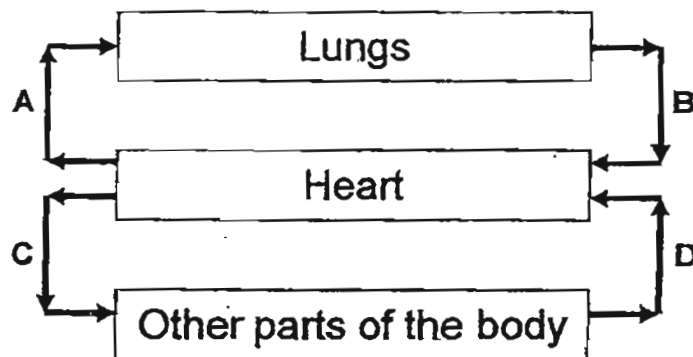

Which of the following statements is correct?

- (1) The blood in C has the most amount of oxygen.
- (2) The blood in A is richer in oxygen than the blood found in D.
- (3) The blood in B has the least amount of carbon dioxide.
- (4) The blood in C contains only oxygen while the blood found in D contains only carbon dioxide.

13) Study the diagram below carefully.

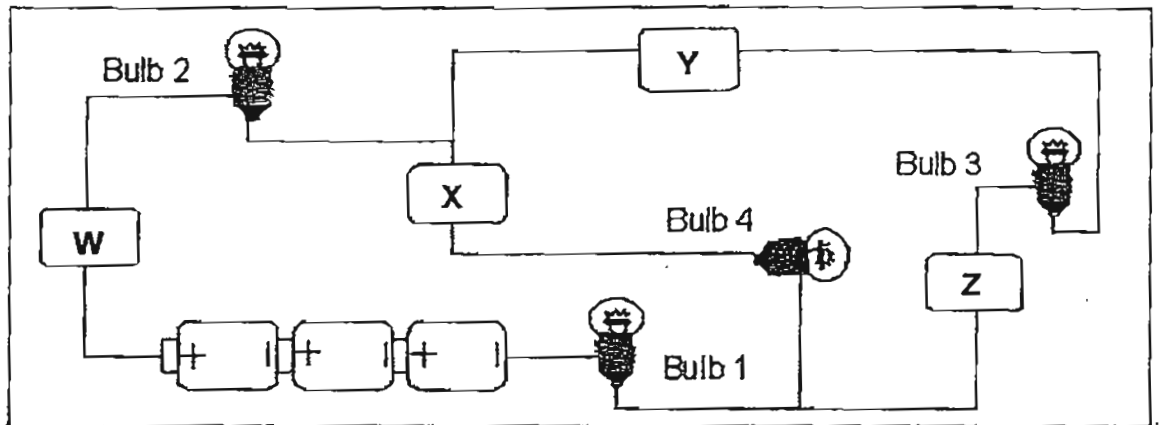

What can W, X, Y and Z be if only Bulb 1, Bulb 2 and Bulb 3 light up?

	W	X	Y	Z
(1)	handkerchief	woollen glove	paper clip	Iron nail
(2)	plastic fork	pencil lead	silver spoon	50-cent coin
(3)	tungsten wire	copper rod	aluminium foil	staple
(4)	steel ruler	tissue paper	magnet	copper wire

14) Lydia set up an electrical circuit with identical bulbs, P, Q and R, and batteries as shown below.

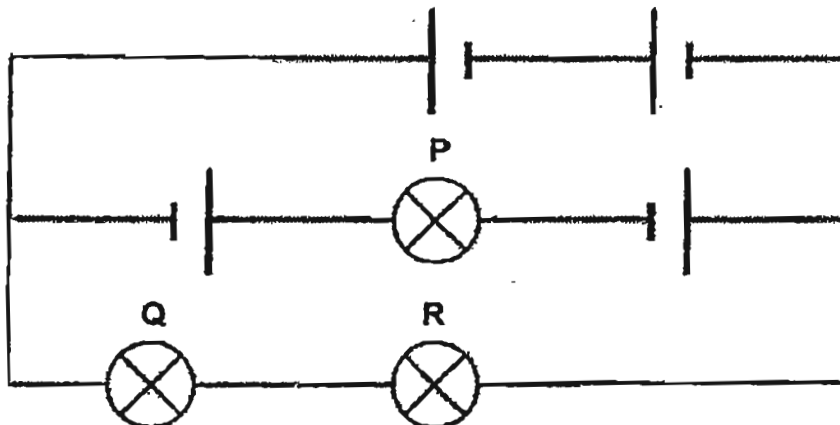

Which of the following is true?

- (1) Bulb P is the brightest.
- (2) Bulb R is brighter than Bulb P.
- (3) Bulb P, Bulb Q and Bulb R are of equal brightness.
- (4) Bulb P is brighter than Bulb Q but dimmer than Bulb R.

15) Jayden sets up an electrical circuit as shown below.

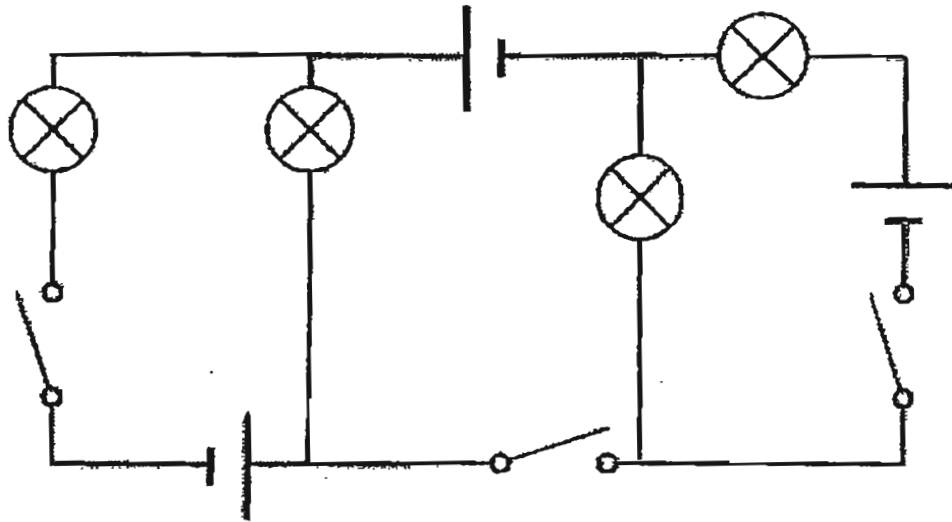

What is the greatest number of bulbs that can light up when 2 switches are closed?

- (1) 1
- (2) 2
- (3) 3
- (4) 4

- 16) The bulb lights up when the circuit tester is connected to points, A and D, of a circuit card.

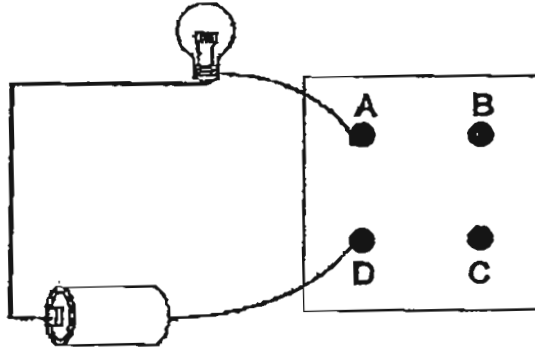

Which of the following shows how the wires are connected at the back of the circuit card?

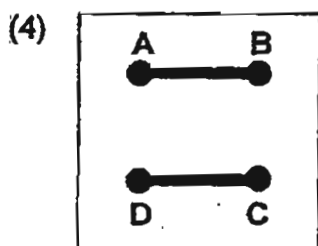
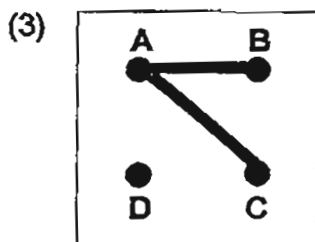
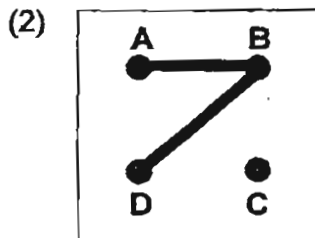
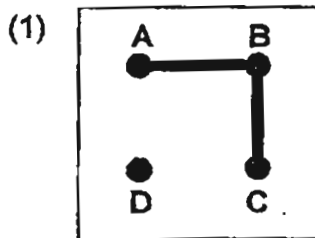

- 17) The graph below shows how the amount of carbon dioxide given to a plant affects the total amount of oxygen produced by the plant over a period of time.

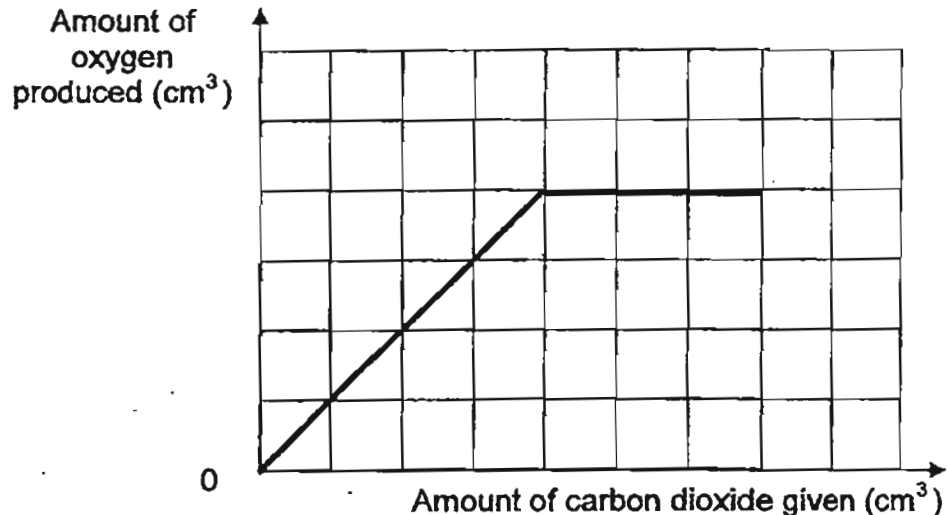

Which of the following best describes the relationship between the amount of oxygen produced and the amount of carbon dioxide given?

- (1) The amount of carbon dioxide given affects the amount of oxygen produced.
  - (2) As the amount of carbon dioxide given increases, the amount of oxygen produced increases.
  - (3) As the amount of carbon dioxide given increases, the amount of oxygen produced remains constant.
  - (4) The amount of oxygen produced increases only up to a certain point as the amount of carbon dioxide given increases.
- 18) Adriel conducted an experiment by placing 2 rods, Rod X and Rod Y, of similar lengths but of different materials on top of a hot surface as shown below.

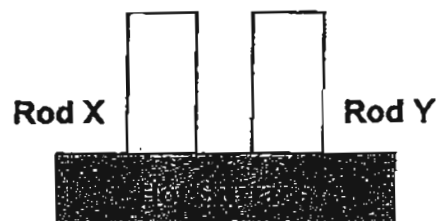

Which observation helped Adriel to arrive at the conclusion that Rod Y is a better conductor of heat than Rod X?

- (1) Rod X feels cooler than Rod Y.
- (2) Rod Y expanded more than Rod X.
- (3) Rod Y has a lower temperature than Rod X.
- (4) Rod Y turned black while Rod X remained the same colour.

- 19) Elisabeth conducted an experiment to find out how the strength of a magnet was affected by the number of times it was dropped. She measured the longest distance that the magnet could attract a paper clip after it was dropped. The results are shown in the table below.

Number of times the magnet was dropped	Distance between the magnet and paper clip (cm)
10	6
20	5
30	4
40	3

From the table, which of the following is most likely to be true?

- (1) The magnet could no longer attract the paper clip after 60 drops.
  - (2) The magnet could attract more than one paper clip before it was dropped.
  - (3) The magnet could attract the paper clip at a distance of 8 cm before it was dropped.
  - (4) The magnet could attract the paper clip from a distance of 4 cm after it was dropped 25 times.
- 20) Five objects, A, B, C, D and E, are made of different materials but are of the same shape and size. A 100g weight was glued to each object. Each object was placed on the surface of a liquid in a tank. The diagram below shows the resting positions of the objects after they were placed in the tank of liquid.

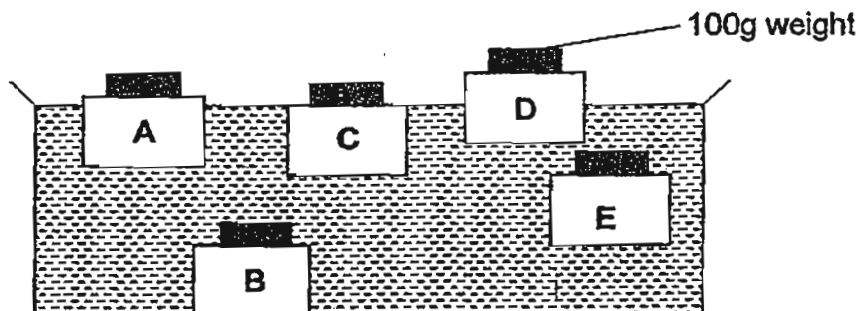

Which of the following shows the order of the objects, starting from the smallest mass to the greatest mass?

- (1) A, B, C, D, E
- (2) B, E, C, A, D
- (3) C, D, A, E, B
- (4) D, A, C, E, B



## PRIMARY 5 END-OF-YEAR EXAMINATION 2011

Name : \_\_\_\_\_ (     ) Date: 31 October 2011

Class : Primary 5 (     )

Time: 8.00 a.m. - 9.25 a.m.

Parent's Signature : \_\_\_\_\_

Marks. \_\_\_\_\_ / 40

# SCIENCE BOOKLET B

### INSTRUCTIONS TO CANDIDATES

Write your name, class and register number.

Do not turn over this page until you are told to do so.

Follow all instructions carefully.

Answer all questions.

**Section B (40 marks)**

**For the questions 21 to 34, write your answers in the spaces provided.**

21) The diagram below shows the human digestive system.

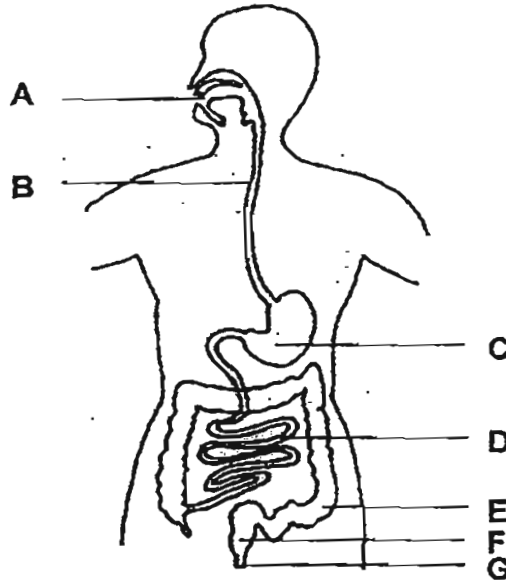

- (a) At which part of the digestive system, A, B, C, D, E, F or G, does digestion end? [1]

---

- (b) At which part of the digestive system, A, B, C, D, E, F or G, is the digested food absorbed into the bloodstream? [1]

---

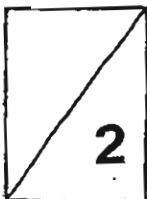



22) The diagrams below show two cells.



Cell A



Cell B

Part X

- (a) One of the cells has a fixed shape. Identify and label in the correct diagram the part of the cell that gives the cell its fixed shape. [1]
- (b) Which cell, Cell A or Cell B, can carry out photosynthesis? Explain your answer. [1]

---

---

---

- (c) What is the function of Part X in Cell B? [1]

---

---

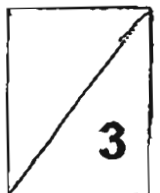

23) Study the flowchart below carefully.

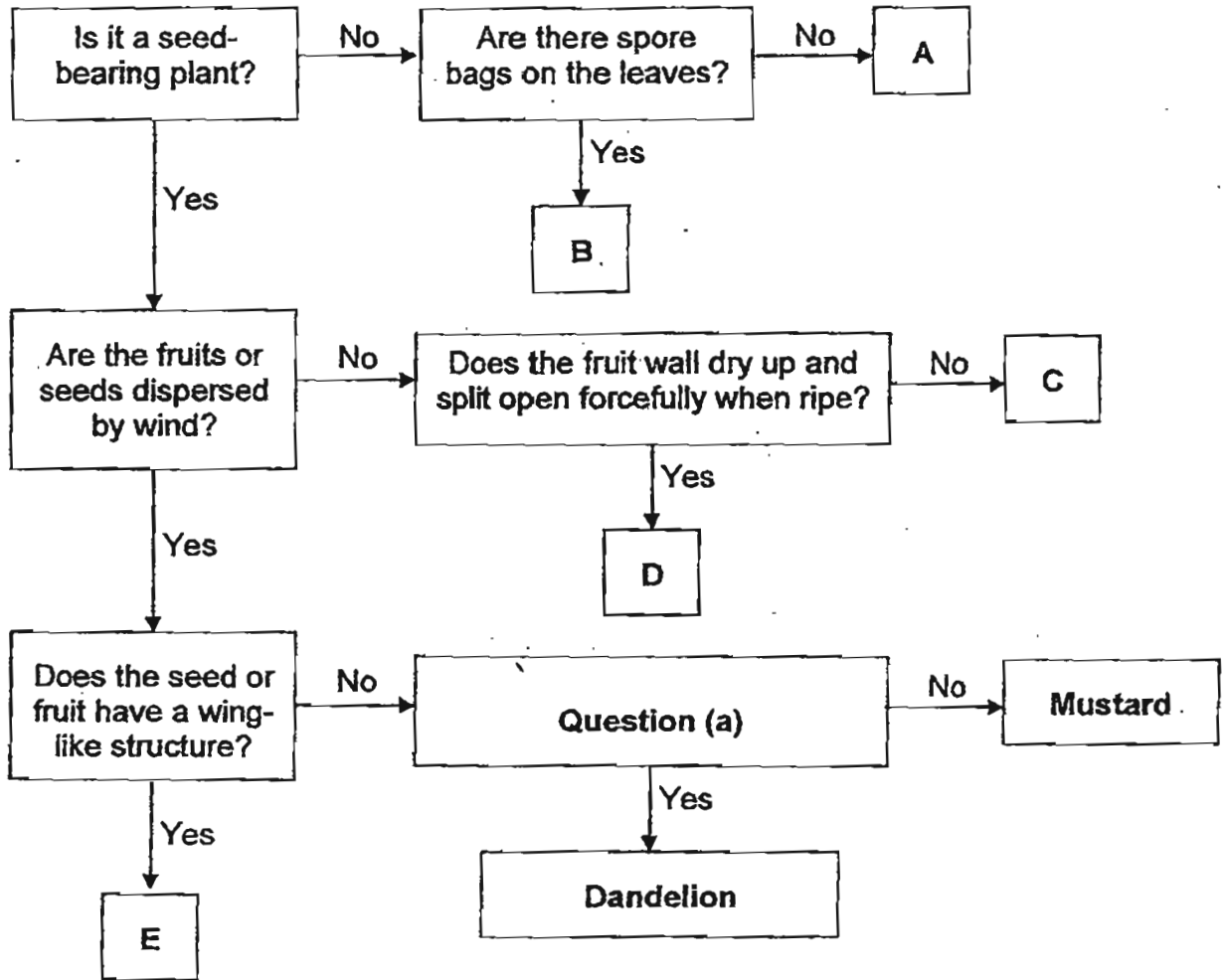

(a) What is Question (a)? [1]

(b)



Fruit X



Fruit Y

Based on the pictures above, which parts of the flow chart, A, B, C, D, or E, represent Fruit X and Fruit Y? [1]

Fruit X : \_\_\_\_\_

Fruit Y : \_\_\_\_\_

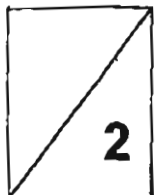

24) Study the picture below carefully.

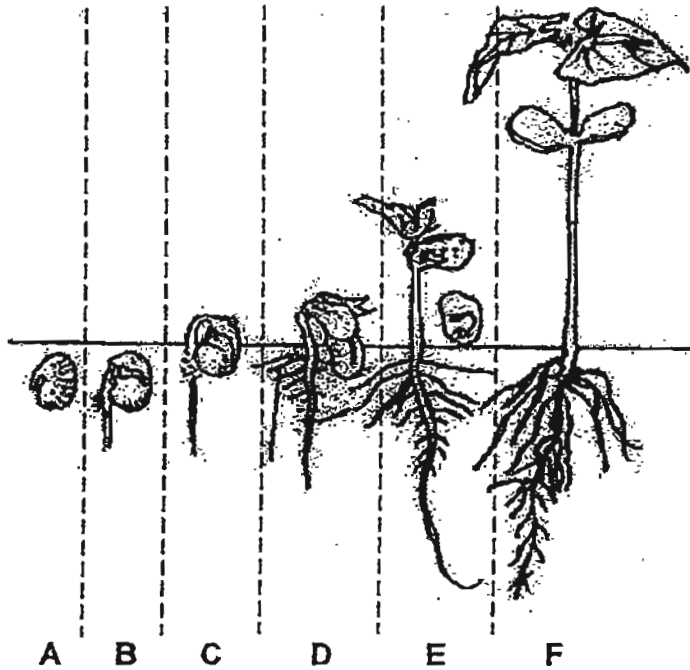

(a) Identify the process at B. [1]

---

(b) Which are the 3 factors required for the process at B to occur? [1]

---

(c) At D, where does the seedling get its food from? [1]

---

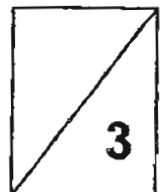

25) The diagram below shows the cross section of the female human reproductive system.

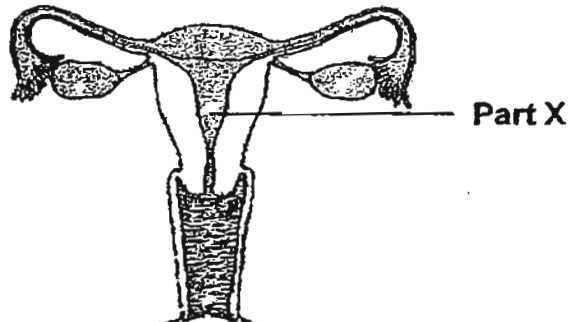

- (a) Identify and label in the diagram above the part where fertilisation usually takes place. [1]
- (b) What is the function of Part X in the process of sexual reproduction in humans? [1]

---



---

26) The diagram below shows a sperm.

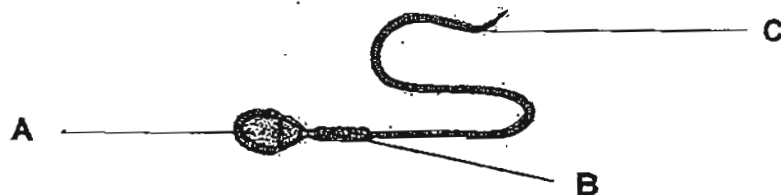

- (a) Which part/(s) of the sperm, A, B or C, will fuse with the nucleus of the egg? [1]

---

- (b) The diagram below shows the male human reproductive system. Shade the part/(s) in the diagram where sperms are produced. [1]

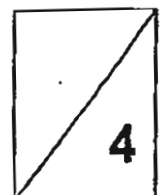
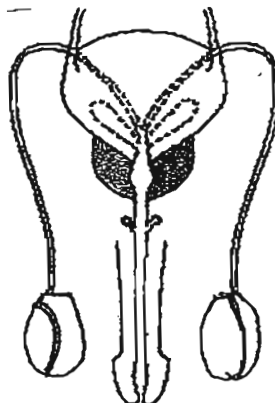

- 27) Fandi set up an experiment as shown below. He suspended an iron nail between 2 rods, one made of iron and another made of plastic. The batteries, wires and switches are identical in both circuits, Circuit A and Circuit B.

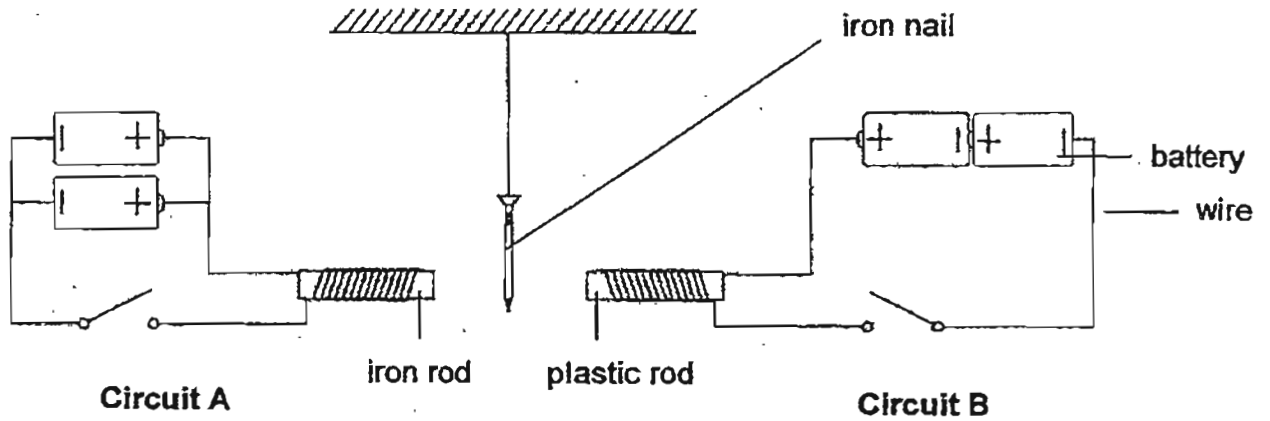

- (a) What will happen to the iron nail when both switches are closed at the same time? [1]

---



---

- (b) What should Fandi do to Circuit B so that the iron nail would move towards it? Explain your answer. [2]

---



---



---

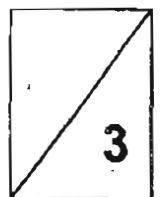

- 28) The table below shows the number of trees in 4 similar plots of land and their surrounding average temperature.

Plot	Number of trees	Surrounding average temperature ( $^{\circ}\text{C}$ )
A	20	31
B	30	27
C	40	?
D	50	24

- (a) Complete the table. What would the surrounding average temperature be when there are 40 trees on plot C? [1]

\_\_\_\_\_

- (b) What is the relationship between the number of trees and the surrounding average temperature? [1]

\_\_\_\_\_

\_\_\_\_\_

- (c) Name the process that the trees go through that helps to lower the average surrounding temperature. [1]

\_\_\_\_\_

\_\_\_\_\_

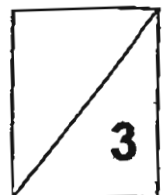

29) Benedict created a bottle garden as shown below.

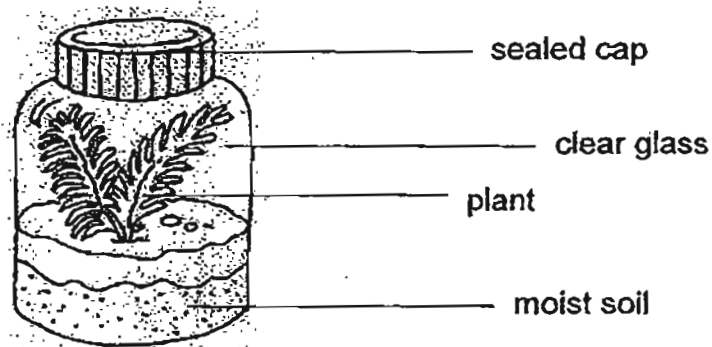

He sealed the bottle garden tightly and left it near the window for a month.

- (a) Explain how the plants in the bottle garden obtained a continuous supply of water over the one month. [2]

---

---

---

---

---

- (b) State how the Sun is important to the process in (a). [1]

---

---

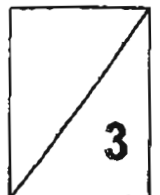

- 30) Jeffrey suspended 2 trays, Tray X and Tray Y, an equal distance away from the ends of a glass tube attached to a conical flask. Both trays are of the same size and temperature but of different materials, plastic or aluminium.

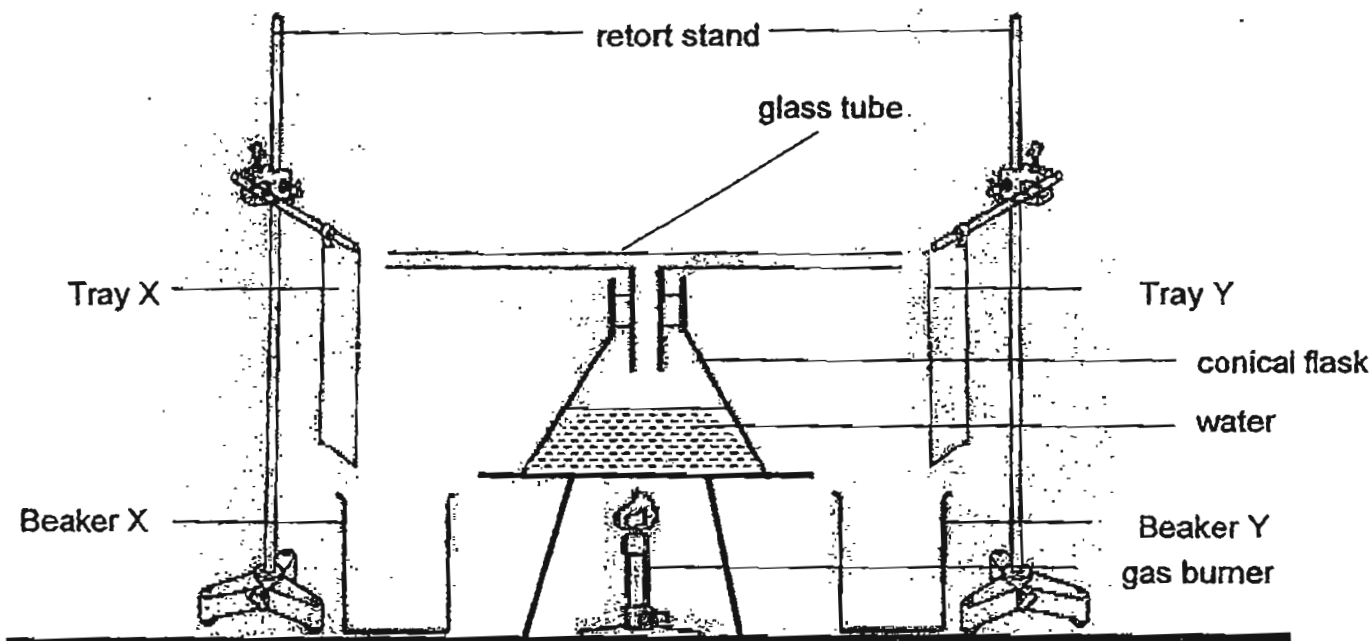

Jeffrey heated the water in the conical flask to boiling point and allowed the water to continue boiling for 10 minutes before removing the gas burner. After 10 minutes, he observed that more water was collected in Beaker X than Beaker Y.

- (a) Which tray, Tray X or Tray Y, is made of plastic? Explain your answer. [1]

---

- (b) If Jeffrey turned up the flame instead of removing the gas burner, what would he observe about the volume of water collected in Beaker X? [1]

---

- (c) Explain your answer in (b). [1]

---



---

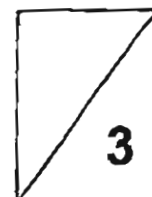



31) The diagrams below show some human body systems.

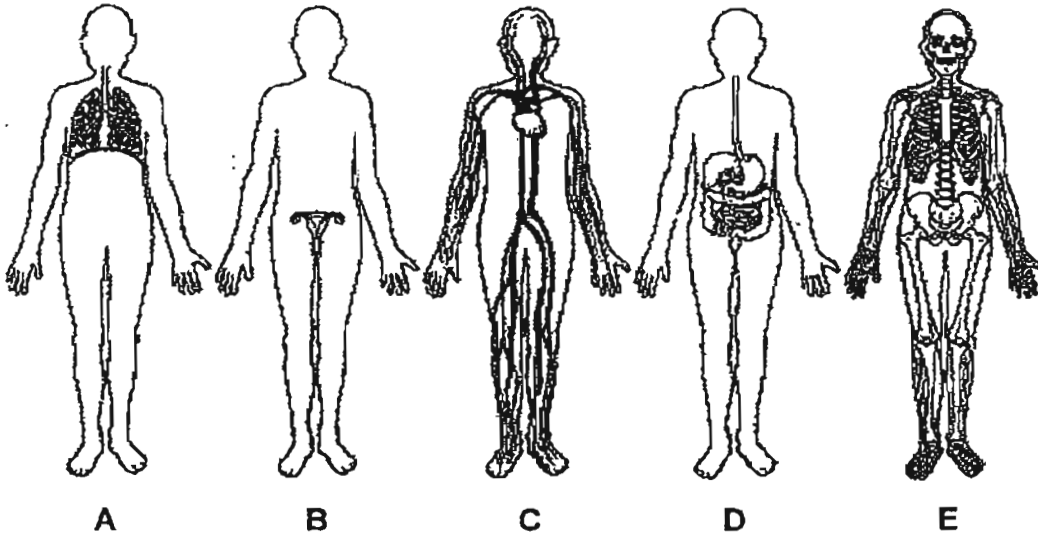

(a) Which of the systems, A, B, C, D and/or E, help/s to remove carbon dioxide from the body? [1]

---

(b) Identify the system/s in (a). [1]

---

(c) Explain how the system/s in (a) help/s to remove carbon dioxide from the body. [1]

---

---

---

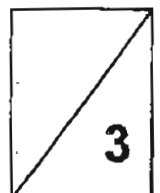

32) Complete the table below about plant systems and human body systems below.

[4]

		Plant Systems	Human Body Systems
(a)	Materials that are transported by the transport systems	<ul style="list-style-type: none"> <li>◆ Water</li> <li>◆ Mineral salts</li> <li>◆ _____</li> </ul>	<ul style="list-style-type: none"> <li>◆ Food</li> <li>◆ _____</li> <li>◆ _____</li> </ul>
(b)	Parts that make up the transport systems	<ul style="list-style-type: none"> <li>◆ Water-carrying tubes</li> <li>◆ _____</li> </ul>	<ul style="list-style-type: none"> <li>◆ Heart</li> <li>◆ Blood</li> <li>◆ Capillaries</li> <li>◆ Veins</li> <li>◆ _____</li> </ul>
(c)	Gas that is given out by the respiratory systems in the day	<ul style="list-style-type: none"> <li>◆ _____</li> </ul>	<ul style="list-style-type: none"> <li>◆ Carbon dioxide</li> </ul>
(d)	Part/(s) which allow/(s) the exchange of gases	<ul style="list-style-type: none"> <li>◆ _____</li> </ul>	<ul style="list-style-type: none"> <li>◆ Nostril</li> <li>◆ Lungs</li> <li>◆ _____</li> </ul>

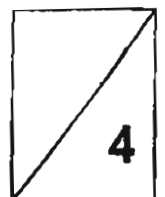

33) Lisa set up an electrical circuit as shown below.

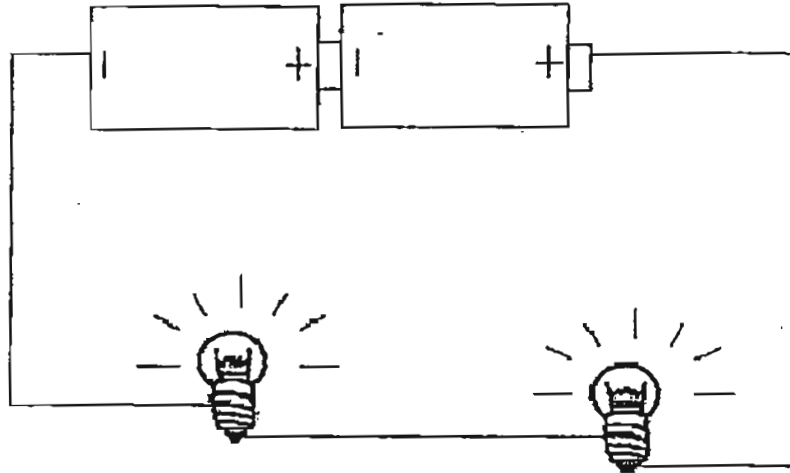

What change/s should Lisa make to the electrical circuit so that both bulbs would glow more brightly with the same number of batteries? Draw the circuit diagram with the change/s in the box below. [3]

**3**

34) Study the circuit diagrams below carefully. All the bulbs are lit.

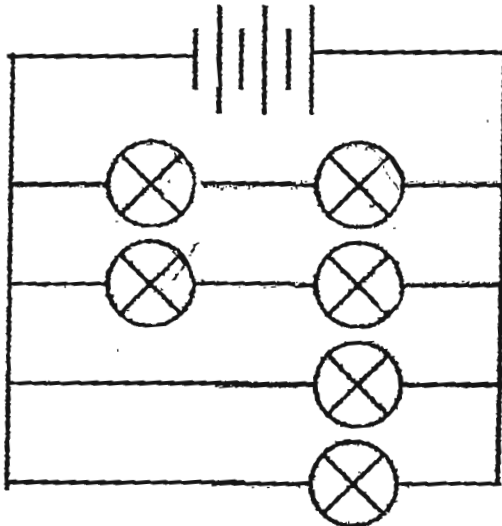

Circuit A

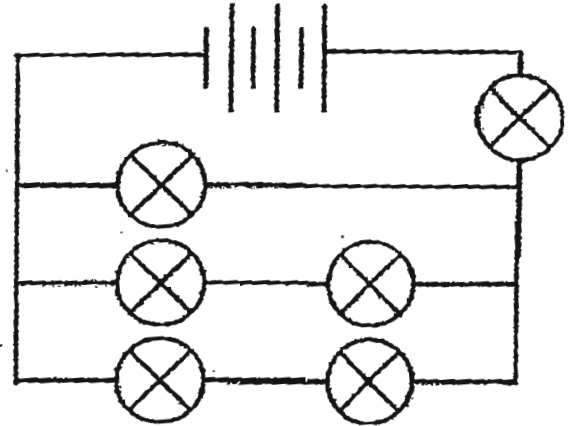

Circuit B

- (a) Complete the table below by writing down the minimum and maximum number of bulbs that will remain lit when one of the bulbs fuses in each electrical circuit. [2]

	Circuit A	Circuit B
Minimum number of bulbs that will remain lit	(i)	(iii)
Maximum number of bulbs that will remain lit	(ii)	(iv)

- (b) Mark with a cross in **Circuit A**, the bulb that has fused in (a)(i). [1]
- (c) Which of the following can be used to replace the bulb that has fused in **Circuit B**, so that the other bulbs will still remain lit? Put a tick (✓) in the correct box/es. [1]

battery

tissue paper

rubber band

steel paper clip

End of Paper



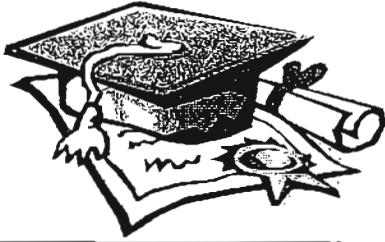

# ANSWER SHEET

**EXAM PAPER 2011**

**SCHOOL : TAO NAN  
SUBJECT : PRIMARY 5 SCIENCE**

**TERM : SA2**

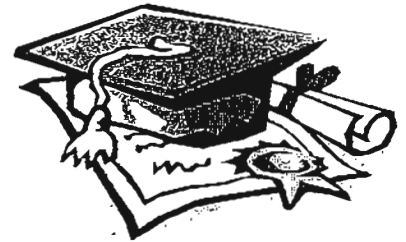

Q1	Q2	Q3	Q4	Q5	Q6	Q7	Q8	Q9	Q10	Q11	Q12	Q13	Q14	Q15	Q16	Q17
4	3	3	2	2	2	2	1	1	1	2	3	4	1	4	2	4

Q18	Q19	Q20
1	4	4

21)a)Part D.            b)Part D.

22)b)Cell A, it has chloroplast that contains chlorophyll to trap light and carry out photosynthesis.

c)Part X allows most activities to take place in the cell.

23)a)Is the seed or fruit inedible.

b)X : D    Y : E

24)a)Germination.

b)Water, oxygen and warmth.

c)The seedling gets its food from the seed leaf.

25)a)  fallopian tube

Part X

b)Part X is where the fertilised egg develops.

26)a)Part A.

b):

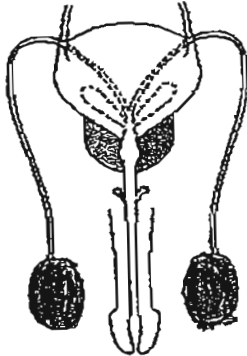

27)a)The iron nail will move towards the iron rod.

b)She should change the plastic rod to an iron rod. As batteries in Circuit A are arranged in parallel and batteries in Circuit B are arranged in series more electricity is provided in Circuit B which causes the iron rod to become a stronger electromagnet.

28)a)25°C

b)The more the number of trees, the lower the surrounding average temperature.

c)Photosynthesis.

29)a)The plant takes in water from the moist soil and gives it out as water vapour.

When the water vapour comes into contact with the cool cap, it condenses into water droplets and drips into the soil.

b)The sun provides heat for evaporation to take place.

30)a)Tray Y is made of plastic, Tray Y has a warmer surface than Tray X and less water will condense on Tray Y.

b)The volume of water will increase.

c)More heat causes water to evaporate into water vapour faster which increases the rate of condensation.

31)a)System A and system C.

b)System A is the respiratory system and system C is the circulatory.

c)The circulatory system pumps blood with carbon dioxide to the lungs and breathes carbon dioxide out.

32)a)Food

/

Oxygen, water

b)Food-carrying tubes

/

arteries

c)Carbon dioxide

/

d)Stomata

/

mouth

33)

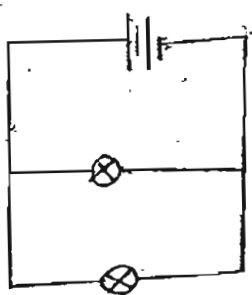

34)a) i) 4    ii) 5    iii) 0    iv) 5  
b)

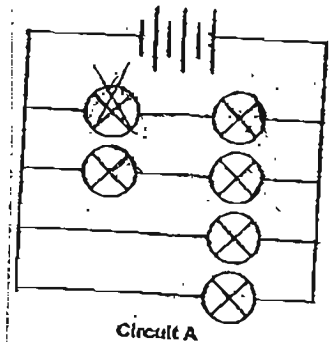

c) battery  
steel paper clip