



NAN HUA PRIMARY SCHOOL
SEMESTRAL ASSESSMENT 1 – 2017
PRIMARY 5

SCIENCE

BOOKLET A

28 Multiple Choice Questions (56 marks)

Total Time for Booklets A and B : 1 hour 45 minutes

INSTRUCTIONS TO CANDIDATES

1. Write your name and index number in the space provided.
2. Do not turn over the page until you are told to do so.
3. Follow all instructions carefully.
4. Answer all questions.
5. Shade your answers in the Optical Answer Sheet (OAS) provided.

Marks Obtained

Booklet A		/ 56
Booklet B		/ 44
Total		/ 100

Name: _____ () Class: P 5 _____

Date : 3 May 2017

Parent's Signature: _____

Section A: (28 x 2 marks = 56 marks)

For each question from 1 to 28, four options are given. One of them is the correct answer. Make your choice (1, 2, 3 or 4). Shade the correct oval (1, 2, 3 or 4) on the Optical Answer Sheet.

1. Which statement(s) about the cells in our body is/are true?

- A Each cell is a basic unit of life.
- B Every cell has a special function.
- C Each cell need food, water and oxygen.

- (1) A only
- (2) B only
- (3) A and B only
- (4) A, B and C

2. Scientists collect seeds and place them in seed bank. These seeds could be germinated when plants die during natural disasters. This method shows that seeds are important in the reproduction of plants because they ensure that_____.

- (1) the plants of their own kind can continue to grow
- (2) offspring have characteristics of the parent plants
- (3) seedlings can be grown under favourable conditions
- (4) young plants are dispersed far away from parent plants

3. Study the diagram below carefully.

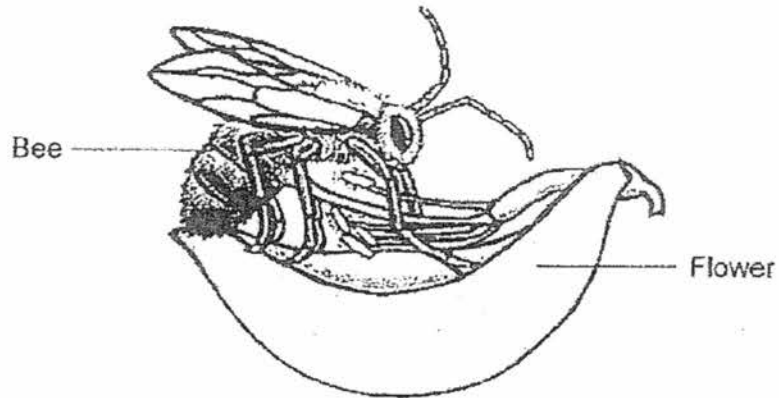

Which one of the following processes of sexual reproduction in flowering plants is shown in the above diagram?

- (1) Pollination
 - (2) Fertilisation
 - (3) Germination
 - (4) Seed dispersal
4. The diagram below shows the female reproductive system of a flowering plant.

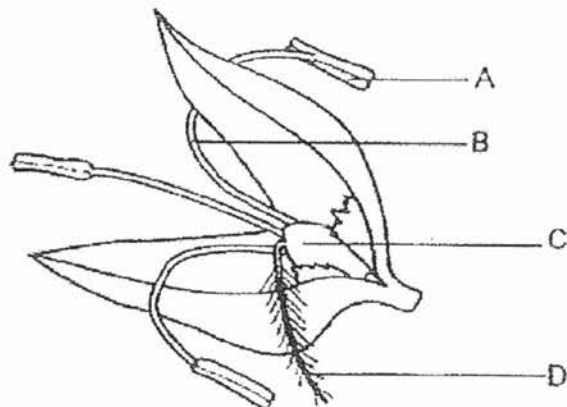

Which part of the system has the same function as the ovary found in human?

- (1) A
- (2) B
- (3) C
- (4) D

5. A stalk of flower was placed overnight in a beaker of water that was dyed blue in colour.

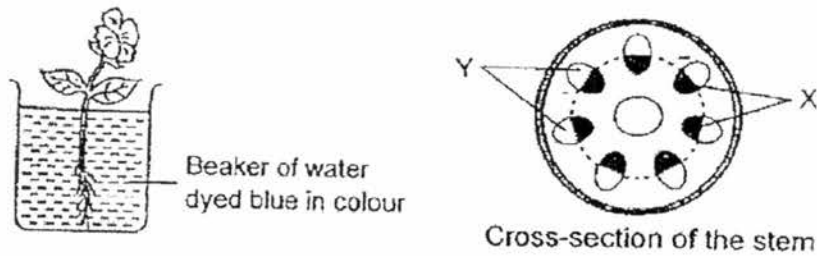

After the experiment, the stem of the stalk of flower was cut to show the cross-section as shown above. The areas, X, turned blue.

Which of the following about X and Y is correct?

	X	Y
(1)	Transports food	Transports water and mineral salts
(2)	Transports food and mineral salts	Transports air and water
(3)	Transports water and mineral salts	Transports food
(4)	Transports air and water	Transports food and mineral salts

6. What are the main parts of our respiratory system?

- (1) mouth, ribs and lungs
- (2) nose, windpipe and lungs
- (3) mouth, windpipe and lungs
- (4) nose, windpipe, ribs and lungs

7. The following pictures show the various systems in a human body.

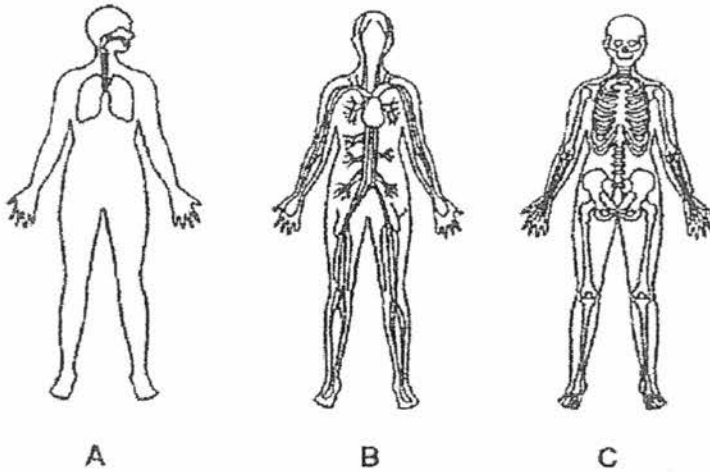

Which of the system(s) above continue to function when you are sleeping at night?

- (1) A only
- (2) B only
- (3) A and B only
- (4) A, B and C

8. Study the diagram below carefully.

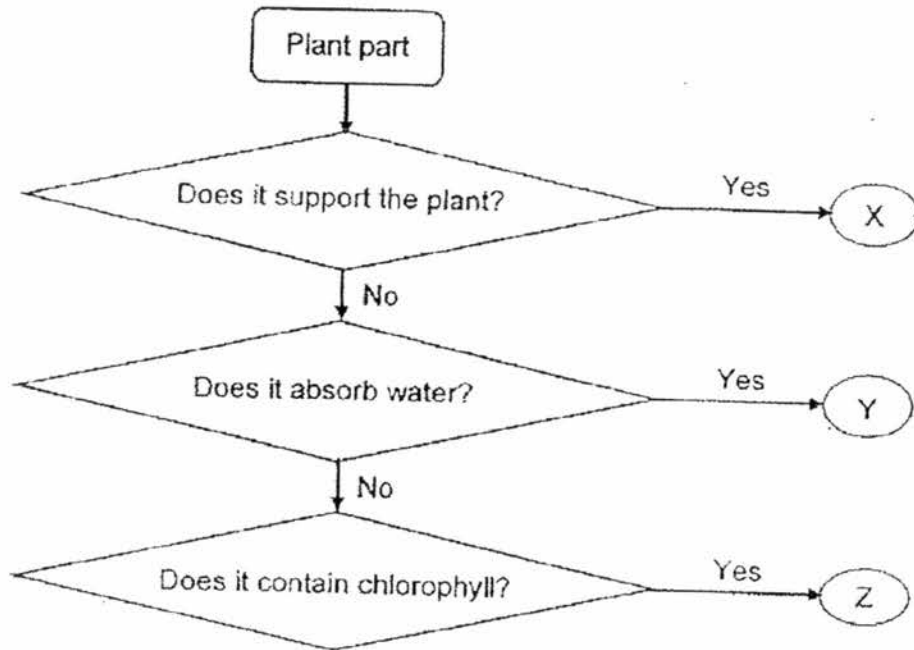

Which of the following shows what X, Y and Z represent respectively?

	X	Y	Z
(1)	root	leaf	stem
(2)	root	stem	leaf
(3)	stem	leaf	root
(4)	stem	root	leaf

9. Study the set-up below carefully. Some starch solution is placed into a plastic bag and dipped into a basin of iodine solution. Iodine solution turns dark blue when it comes into contact with starch. After one hour, the starch solution in the plastic bag turned dark blue but the iodine solution in the basin remained unchanged.

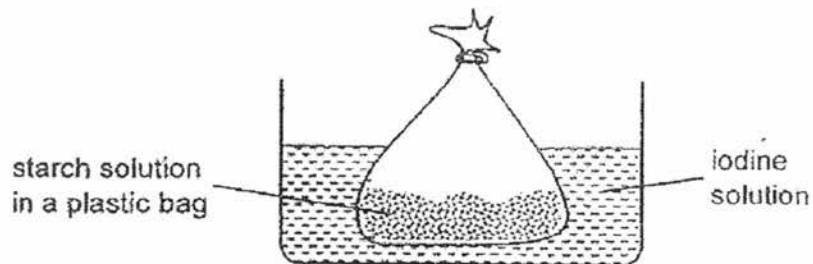

Which part of the cell could be represented by the plastic bag to explain what had happened in the experiment?

- (1) Nucleus
- (2) Cytoplasm
- (3) Chloroplasts
- (4) Cell Membrane

The diagram below shows the distribution of plants W, X, Y and Z.

Questions 10 and 11 are based on the diagram.

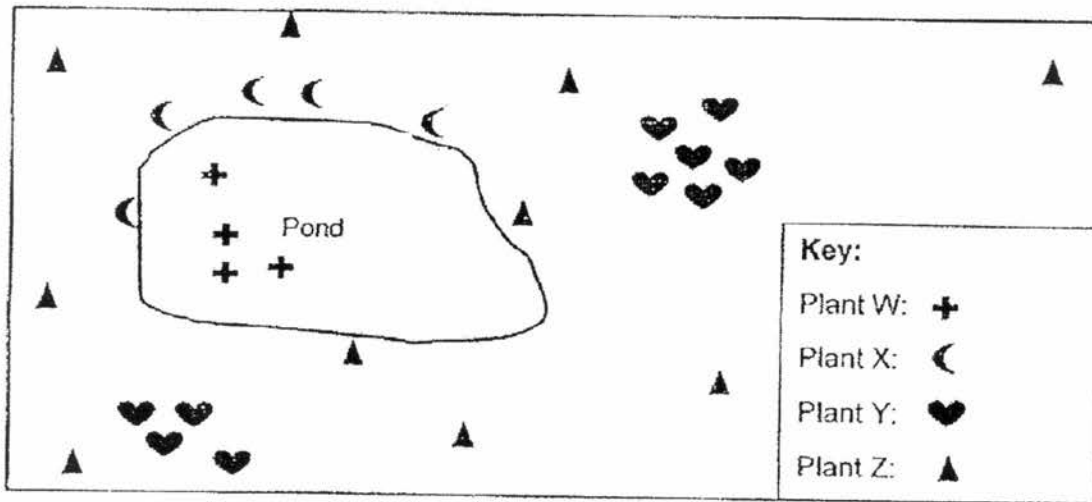

10. Which of the following plant has fruits with stiff hairs?

- (1) Plant W
- (2) Plant X
- (3) Plant Y
- (4) Plant Z

11. The following statements describe the plants.

- A. Seeds of Plant Y may have wing-like structures.
- B. Fruits of Plant W and Plant X have fibrous parts.
- C. Plant Y experiences higher chances of overcrowding

Based on your observations of the diagram above, which statement(s) is/are most likely to be correct?

- (1) A only
- (2) A and B
- (3) B and C
- (4) A, B and C

12. Which diagram shows the correct movement of food in a germinating seed?

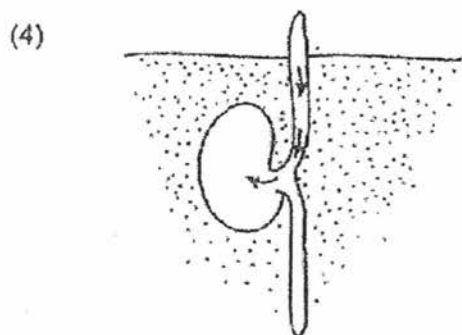
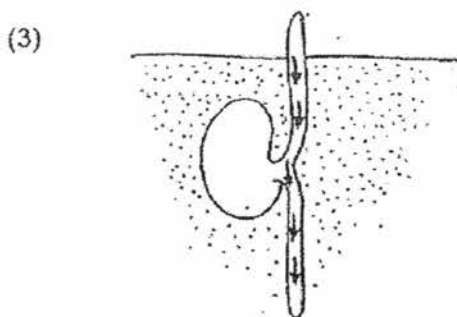
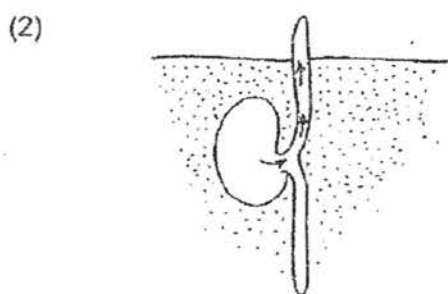
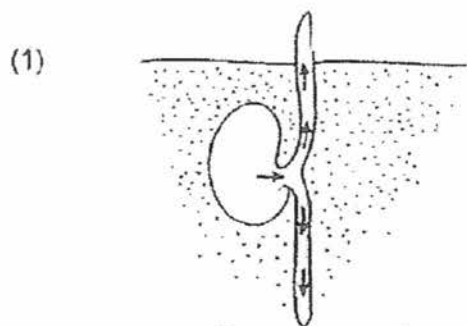

3. The female reproductive system usually releases one egg every month. A woman eats substance X regularly to increase chances of fertilisation. Substance X most likely works by increasing_____.

- (1) the size of the womb
- (2) the number of sperms produced by the testes
- (3) the number of eggs released by the ovaries monthly
- (4) the number of ovaries in the female reproductive system

4. The diagram below shows a lizard kept in a sealed glass jar.

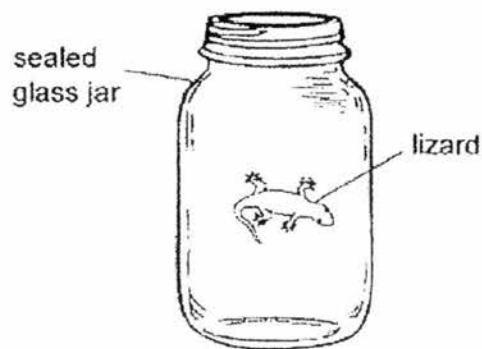

Which one of the graphs below shows how the amount of oxygen and carbon dioxide changed over fifteen minutes?

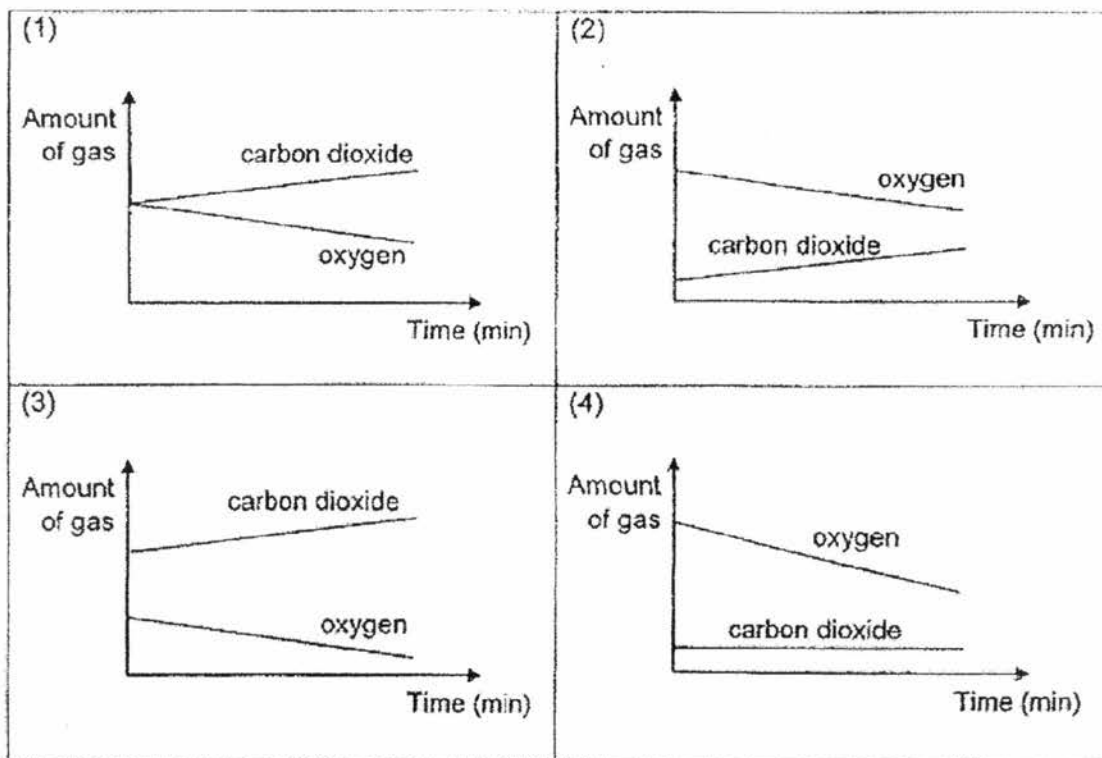

15. The diagrams below show the respiratory systems of a human and a fish.

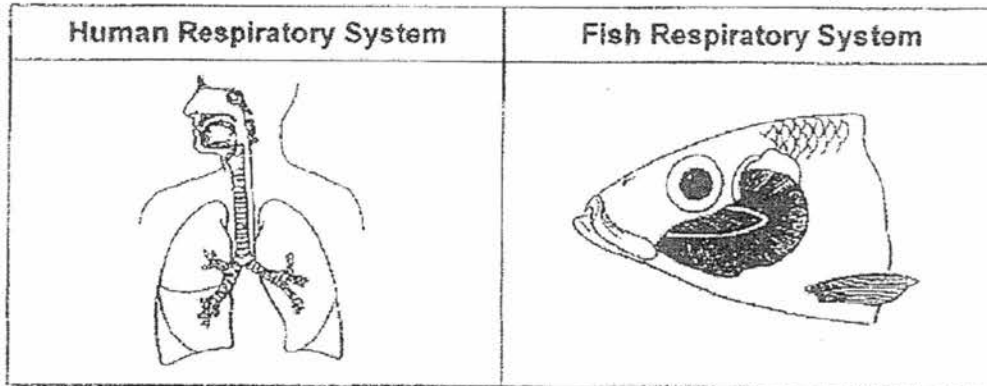

Which statement(s) about the human and fish respiratory systems is/are correct?

- A Both systems take in oxygen and release carbon dioxide into the air.
 - B Gaseous exchange occur in the lungs of the human and at the gills of the fish.
 - C The human take in air through the nose but the fish take in water through the mouth.
- (1) A only
(2) B only
(3) A and C only
(4) B and C only
16. Which of the following statements correctly describe what happens to the food in the mouth before it is swallowed?
- A The food is dissolved in saliva.
 - B The food becomes moist and slippery.
 - C The food is broken up into smaller pieces.
 - D The food is starting to be broken down into simple substance.
- (1) A and B only
(2) C and D only
(3) A, B and C only
(4) B, C and D only

17. The diagram below shows how food travels in our body.

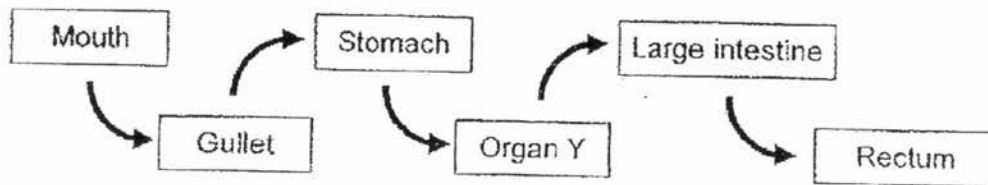

What happens if Organ Y is not working?

- A More digestive juice cannot be added.
- B Water cannot be absorbed into the bloodstream.
- C Digested food cannot be absorbed into the blood stream.

- (1) A and B only
- (2) A and C only
- (3) B and C only
- (4) A, B and C

18. The diagram below shows four objects.

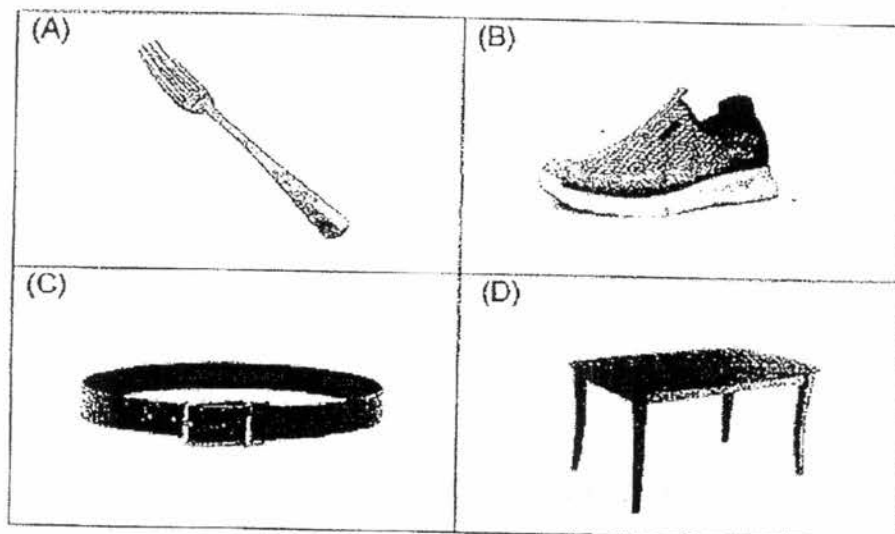

Which objects above have to be made of a flexible material?

- (1) A and D only
- (2) B and C only
- (3) A, B and C only
- (4) B, C and D only

19. Five magnets are connected as shown in the diagram below.

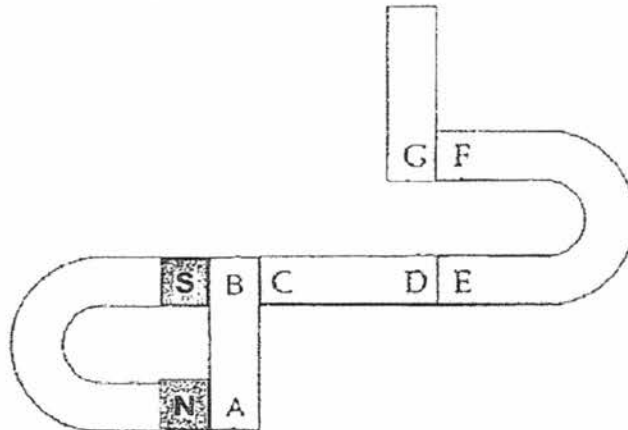

What are the poles of A, D, F and G respectively?

	A	D	E	G
(1)	South	North	South	South
(2)	North	South	North	North
(3)	South	North	North	South
(4)	North	South	North	North

20. The diagram below shows the water cycle.

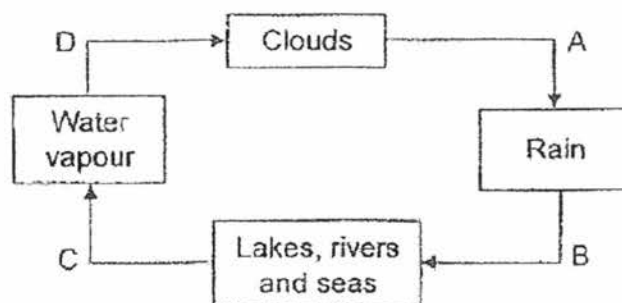

Which statement(s) about the water cycle is/are true?

- A The Sun provides the heat for processes C and D.
- B Plants and animals also provide the water vapour for the water cycle.
- C Only process B ensures a constant supply of water to lakes, rivers and seas.

- (1) A only
- (2) B only
- (3) A and B only
- (4) B and C only

21. Sally carried out an experiment to test the strength of four materials for making fishing lines. She added weights of 2 kg to the strings made of the four different materials until the strings broke.

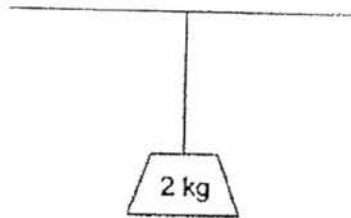

Sally recorded the results in the table below.

Number of weights added until the string breaks			
String W	String X	String Y	String Z
3	7	4	5

To catch a fish of more than 10 kg, which string should Sally use?

- (1) String W
- (2) String X
- (3) String Y
- (4) String Z

22. The diagram below shows paper bags used by many shops. Paper is made from wood that comes from trees that will not pollute the earth unlike plastic bags.

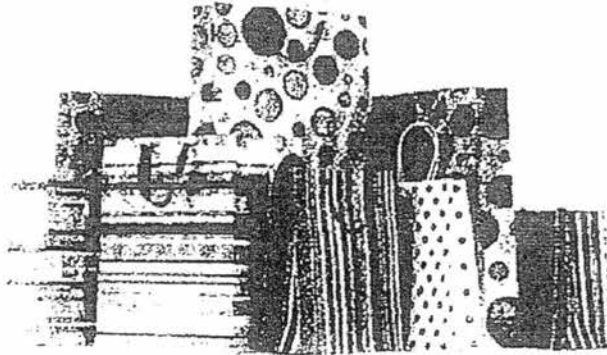

The supermarkets that use a lot of plastic bags should consider changing to paper bags to reduce pollution.

Which property/properties of plastic is/are the possible reason(s) why supermarkets continue to use plastic bags instead of paper bags?

- A strong
- B waterproof
- C translucent

- (1) A only
- (2) A and B only
- (3) A and C only
- (4) B and C only

23. Damien placed a piece of cardboard between a paperclip and a magnet.

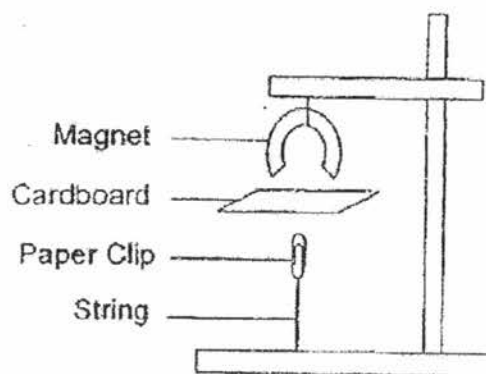

What does the above experiment show?

- (1) The magnet can act at a distance.
- (2) The paper clip is a temporary magnet.
- (3) The string is made of a magnetic material.
- (4) Magnetic force cannot pass through the cardboard.

24. Siti wants to find out how the magnetic strength of a temporary magnet is affected by the number of strokes made by the magnet.

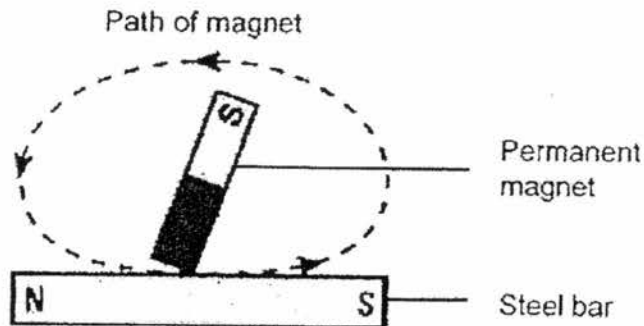

She magnetised four identical steel bars by stroking them with a magnet for different number of times. After each steel bar was magnetised, she placed each steel bar 5 cm above a bowl of pins.

The results of the experiment are recorded in the table below.

Number of strokes received by steel bar	Number of pins attracted		
	1 st attempt	2 nd attempt	3 rd attempt
10	4	3	4
20	5	6	6
30	7	13	8
40	10	10	11

Siti decided that the circled value is unusually high. She removed the reading before calculating the average number of pins picked up for each temporary magnet before making a conclusion. This shows that repeating the experiment increases the _____ of the result.

- (1) fairness
- (2) reliability
- (3) variables
- (4) accuracy

25. The diagram below shows a conveyor belt that is used to separate waste. The roller drum at the end of the conveyor belt is a magnet.

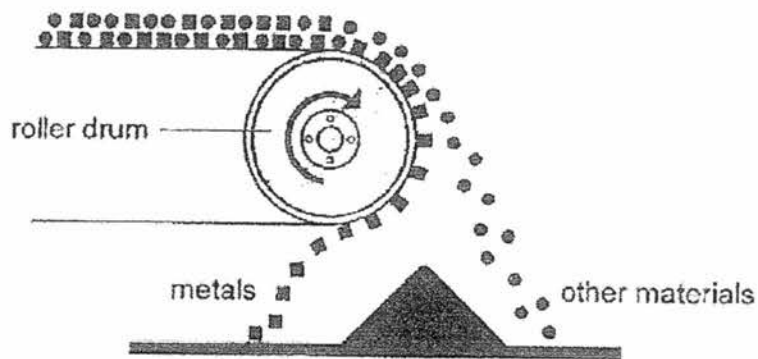

Which option correctly shows the metals and materials separated by the machine?

	Metals	Other materials
(1)	Copper and Iron	Plastic and Paper
(2)	Iron and Steel	Glass and Plastic
(3)	Aluminium and Copper	<u>Iron</u> and Paper
(4)	Aluminium and Steel	<u>Iron</u> and Glass

26. Jimmy set up an experiment. He filled two identical beakers with 100 ml of water at room temperature and heated them as shown below. The size of the flame of the three bunsen burners were kept the same.

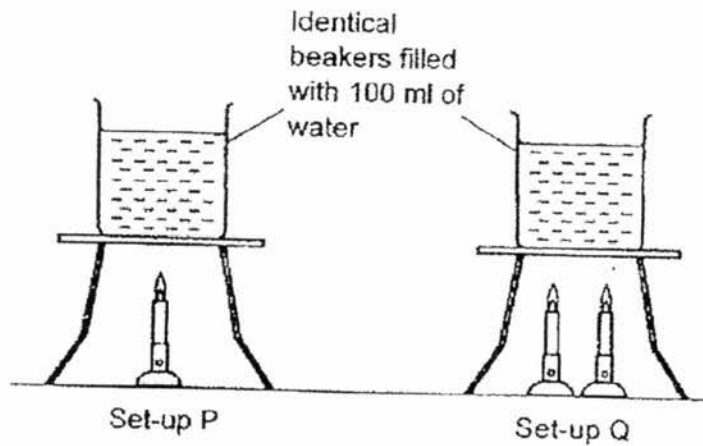

Jimmy measured the temperature of the water in both beakers at the start of the experiment. Which graph correctly shows how the temperature of both beakers changed?

(1)

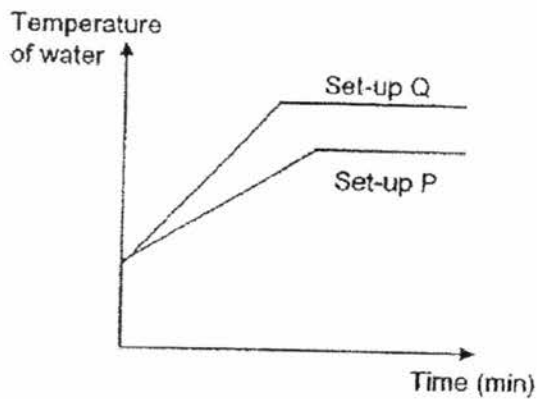

(2)

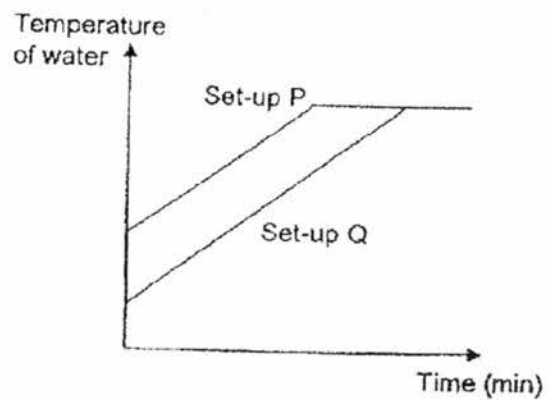

(3)

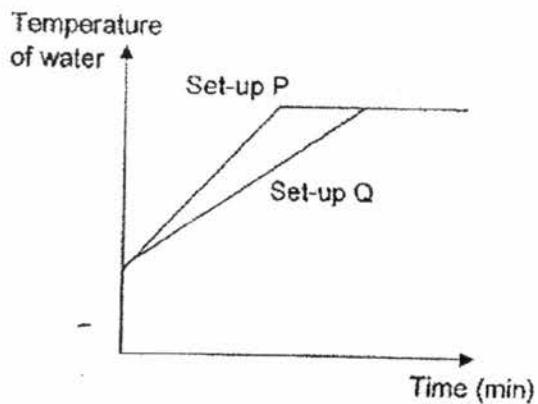

(4)

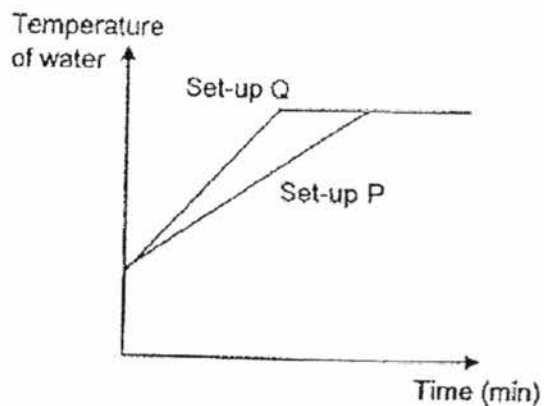

27. Sam poured different amount of water at 80°C into three cups of similar size.

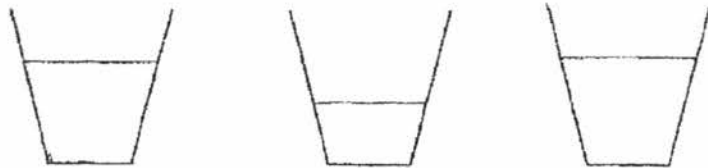

A: Metal Cup with 100 ml of water

B: Metal Cup with 50 ml of water

C: Plastic Cup with 100 ml of water

Arrange the cups according to the amount of heat in the water after ten minutes, from the least amount of heat to the most amount of heat.

- (1) A, B, C
- (2) B, C, A
- (3) B, A, C
- (4) C, A, B

28. Mrs Lim placed the following set-up in a basin of ice.

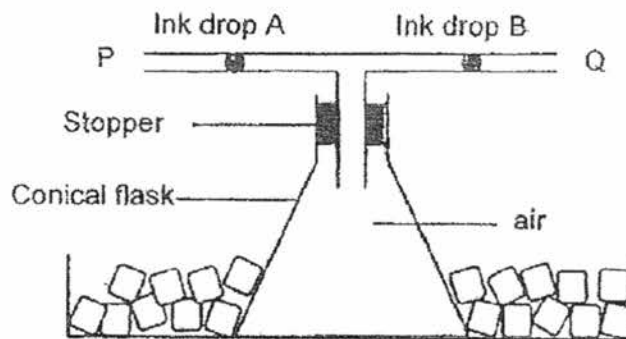

After ten minutes, ink drops A and B will move towards _____.

- (1) P
- (2) Q
- (3) each other
- (4) towards P and Q respectively



NAN HUA PRIMARY SCHOOL
SEMESTRAL ASSESSMENT 1 – 2017
PRIMARY 5

SCIENCE

BOOKLET B

13 Open-ended questions (44 marks)

Total Time for Booklets A and B : 1 hour 45 minutes

INSTRUCTIONS TO CANDIDATES

1. Write your name and index number in the space provided.
2. Do not turn over the page until you are told to do so.
3. Follow all instructions carefully.
4. Answer all questions.
5. Write your answers in this booklet.

Marks Obtained

Section B

	/ 44
--	------

Name: _____ () Class: P 5 _____

Date : 3 May 2017

Parent's Signature: _____

Section B: (44 marks)

Write your answers to questions 29 to 41.

The number of marks available is shown in brackets [] at the end of each question or part question.

29. Study the table below carefully.

	Has part X	Has part Y
Plant cell	Yes	Yes
Animal cell	No	Yes

(a) If both cells have nuclei, identify part X and Y. [1]

Part X: _____

Part Y: _____

(b) The skeleton of an animal supports its body and gives it its shape. Which part of the plant cell performs this same function? [1]

Score	2
-------	---

30. The diagram below shows the African Tulip and the Pea.

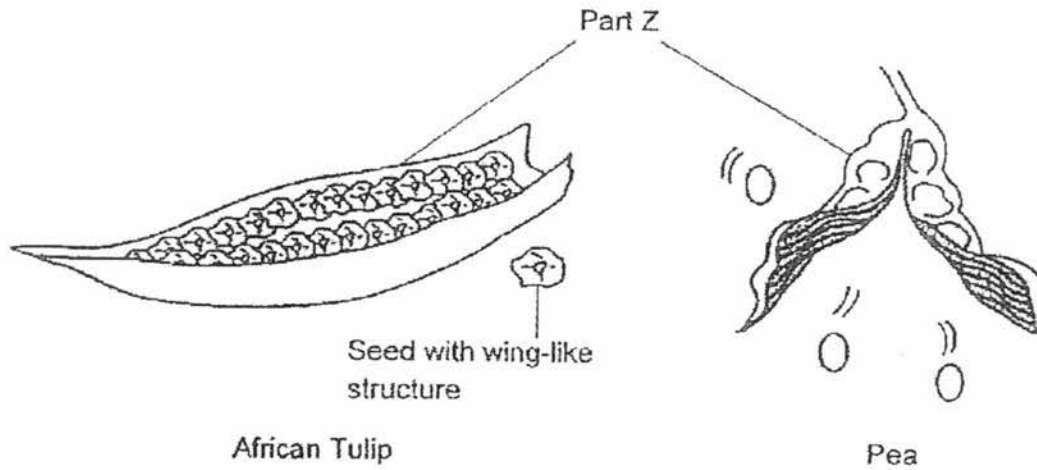

(a) Based on your observations, which seeds will be dispersed further? Explain your answer. [2]

(b) Part Z is found to be dry and thin in the African Tulip and Pea. Which part of the flower is Part Z before fertilisation took place? [1]

Score	3
-------	---

31. The diagram below shows a sperm cell and an egg cell.

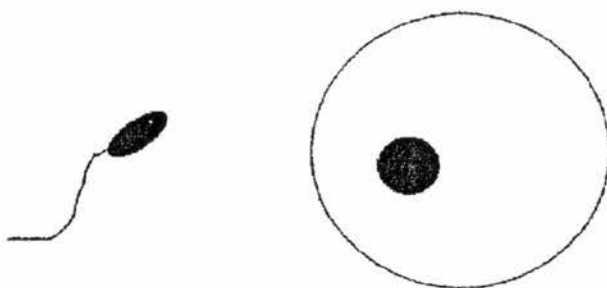

- (a) What must happen between the sperm and the egg in order for fertilisation to happen? [1]

- (b) Children often have similar traits with their parents. Which cell part in the sperm and egg is responsible for this? [1]

- (c) State a function of the cell part mentioned in (b). [1]

Score	3
-------	---

32. Tom set up the apparatus as shown below.

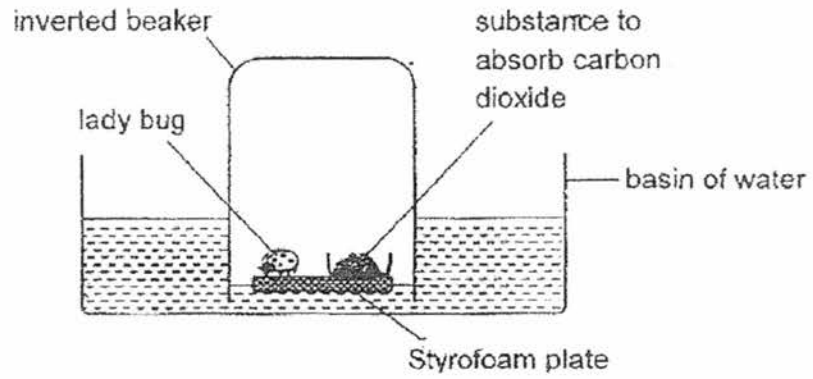

(a) What would happen to the water level in the inverted beaker after one hour? [1]

(b) How did the lady bug cause the change in the water level in the beaker in part (a) above? [2]

Score	3
-------	---

33. Study the flow chart below carefully.

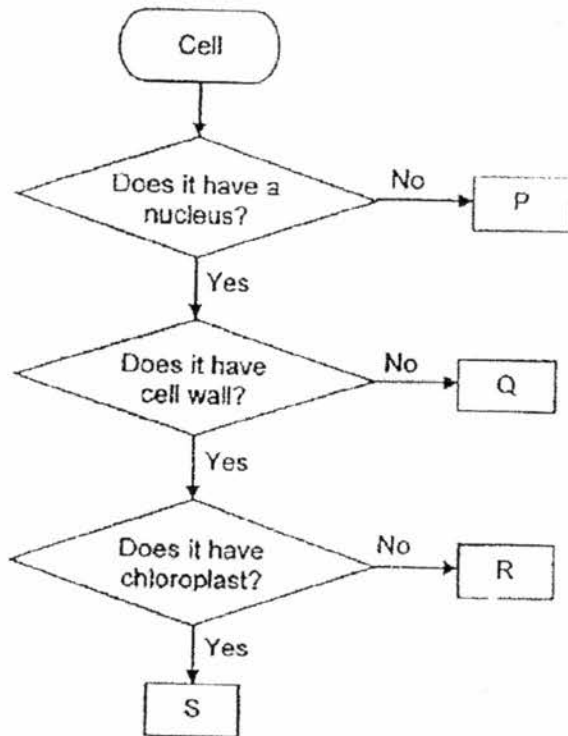

(a) Match P, Q, R or S to the appropriate blanks below.

[1]

(i) Leaf cell: _____

(ii) Root cell: _____

(b) Explain your answer in part (a).

[1]

Score	2
-------	---

34. The diagram below shows the dispersal patterns of Plant A and Plant B .

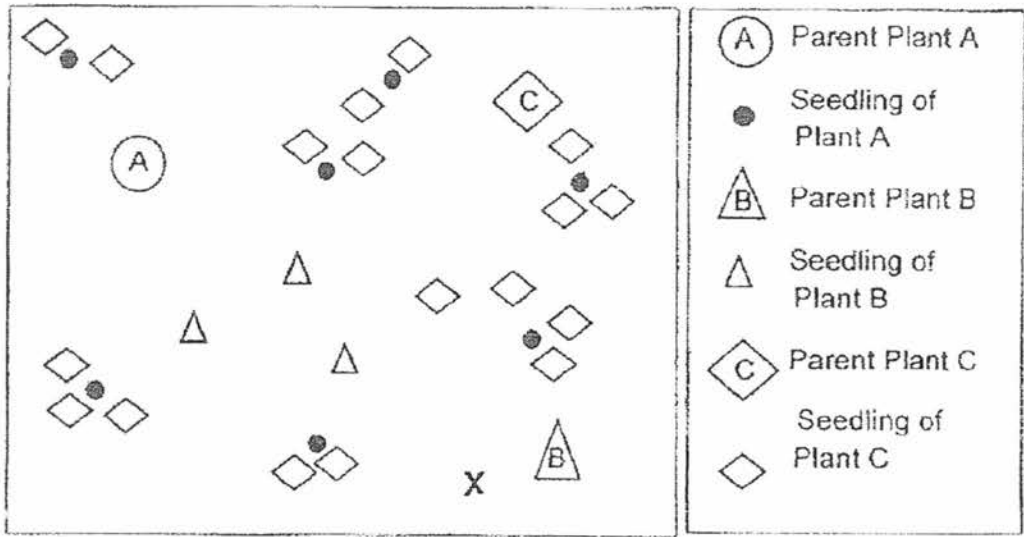

(a) State the dispersal method of Plant A and Plant C. [1]

i. _____ dispersal

ii. _____ dispersal

(b) It is observed that the seedlings of Plant A did not grow well even though they are dispersed far away from their parent and each other. State a possible reason. [2]

(c) Plant B is dispersed by the wind. Draw an arrow starting from point X in the diagram above to indicate the direction of the wind. [1]

Score	4
-------	---

35. Cross-pollination happens when a flower is pollinated by pollen grains from another flower of a plant. A farmer wants to prevent cross-pollination to happen in his farm. He grows Type D tomatoes and Type E tomatoes. The table below shows the flowers of these tomato plants.

Flower of Type D tomato plant	Flower of Type E tomato plant
<ul style="list-style-type: none"> • Orange in colour • Sweet-smelling • Blooms in April 	<ul style="list-style-type: none"> • Yellow in colour • Sweet-smelling • Blooms in July

- (a) How are pollen grains from the anthers transferred to the stigma of the flower? Explain your answer. [2]

- (b) Explain why cross-pollination between these two types of flowers cannot take place in the farm? [1]

- (c) Anther is the part of the flower that produces male reproductive cells in pollen grains. Which part in the human produces male reproductive cells? [1]

- (d) The following diagram shows the male reproductive system in human. Mark a cross to indicate the part mentioned in (c). [1]

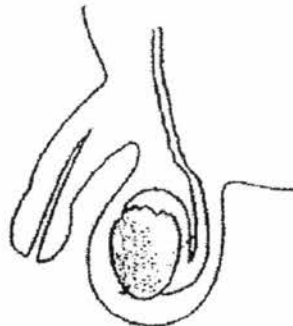

7

Score	/	5
-------	---	---

36. Dan placed two identical plants into two identical jars, each containing water at the same level as shown below. The roots of the plant in Set-up B had been tightly wrapped with a plastic bag. He placed both set-ups under the sun for an hour.

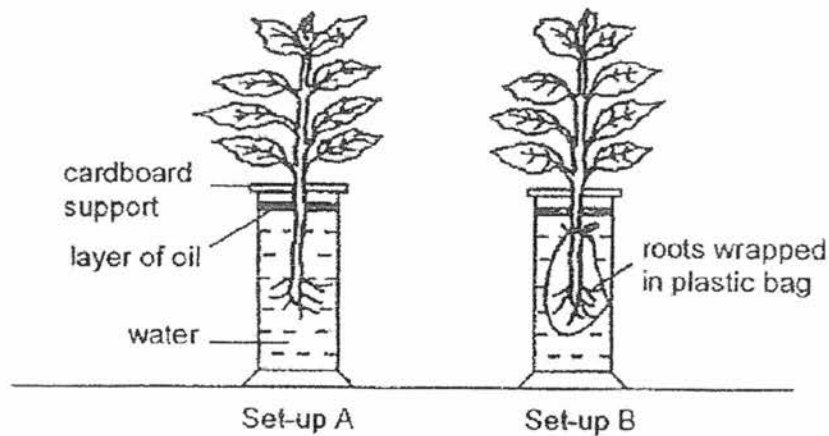

- (a) At the end of the experiment, Dan measured the height of water left in each jar. He found the height of water in Set-up A to be 85 mm. Complete the table to show the possible result for Set-up B. [1]

	Height of water at first (mm)	Height of water after 1 hour (mm)
Set-up A	200	85
Set-up B	200	

- (b) Explain the purpose of the layer of oil in the jars. [2]

- (c) Explain clearly why the water in set-up A was lower. [1]

Score	4
-------	---

37. The picture below shows a plastic water bottle that we bring outdoors.



(a) Name two properties and explain why plastic is a better material for making Part X instead of glass? [2]

i) _____

ii) _____

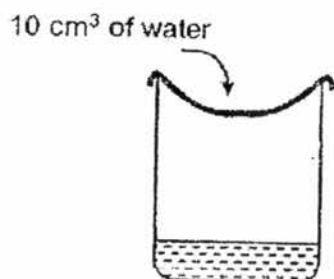

A piece of fabric is placed over a beaker as shown in the diagram above. 10 cm³ of water is poured into the beaker through the fabric. The amount of water collected in the beaker using three different fabric, A, B and C, is measured and recorded in the table below.

Fabric	A	B	C
Amount of water collected in the beaker (cm ³)	9	6	8

- (b) Which fabric is most suitable to make a bath towel? Explain your answer using the results in the table. [2]

- (c) Name two factors about the three fabric used that need to be kept constant to ensure a fair test. [1]

Score	5
-------	---

38. An investigation was carried out using the same batteries, iron rods and paper clips. The results of the investigation are shown below.

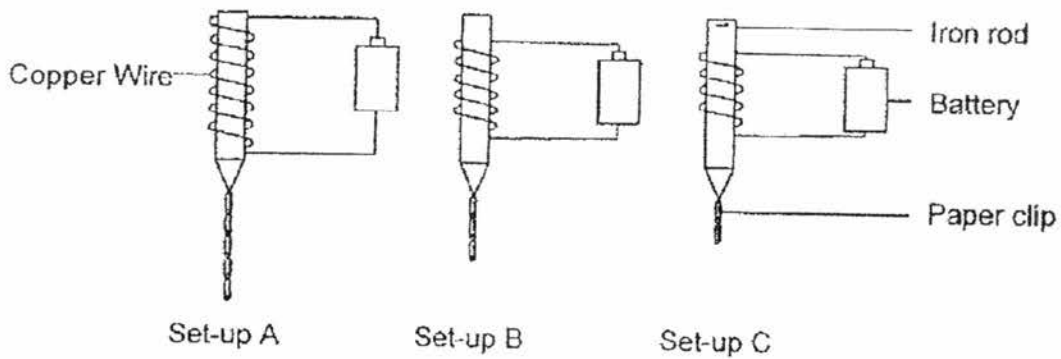

- (a) Identify the following variables of the above experiment. [1]

Dependent (measured) variable: _____

Independent (changed) variable: _____

- (b) Explain why set-up A attracted the most number of clips. [1]

- (c) Besides adding more coils around the rod, what is another method that can increase the number of paper clips attracted? [1]

- (d) Peter replaced the iron rod with a copper rod. Would the rod still be able to attract the paper clips? State a reason. [1]

Score	4
-------	---

39. Tommy kept some water boiling in an electric kettle. He brought a metal plate at room temperature to the spout of the kettle as shown below. He collected and measured the amount of water that dripped from the metal plate for one minute.

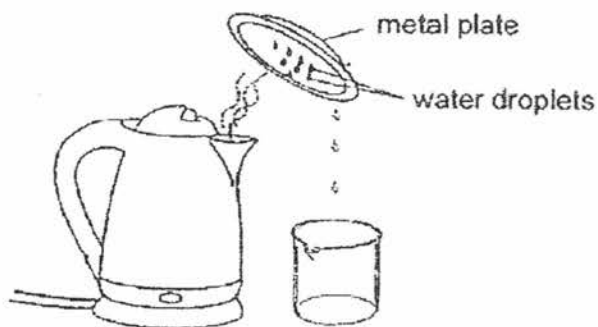

- (a) Explain clearly how the water droplets are formed on the metal plate. [2]

Tommy repeated the experiment above with another metal plate taken from the refrigerator.

- (b) Would Tommy collect more or less water in the beaker in one minute? Explain your answer. [1]

- (c) While observing the water dripping into the beaker from both metal plates, Tommy noticed that less water droplets fell into the beaker nearer to the end of the observation.

What could be the reason for this? [2]

40. Containers in set-ups A, B and C are of the same size and thickness but made of different materials. The containers were filled with the same volume of water at 70°C and left on a table.

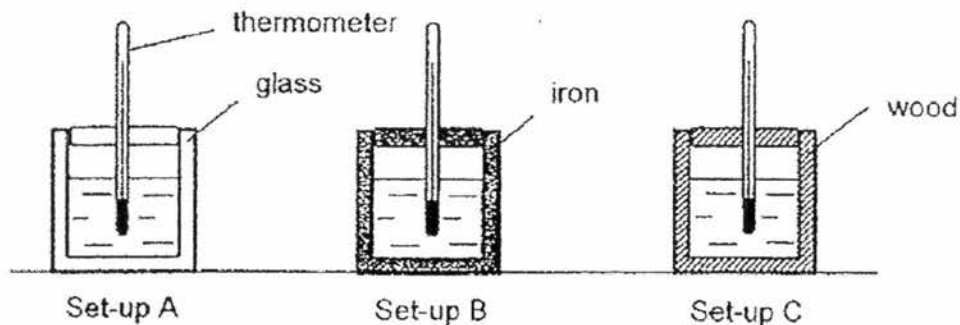

The graph below shows the temperature of water in set-ups A, B and C over a period of time

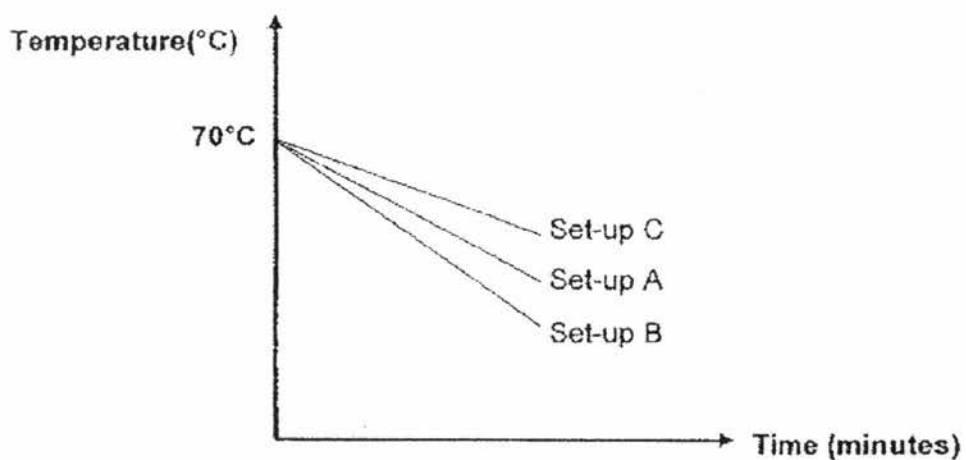

- (a) Based on the graph, which material (glass, iron or wood) is the poorest conductor of heat? Explain your answer. [2]

Tom prepared two identical cups of ice water. He used a metal spoon for one cup and a wooden spoon for another. When he touched the spoons, he realised that the metal spoon felt much colder than the wooden spoon.

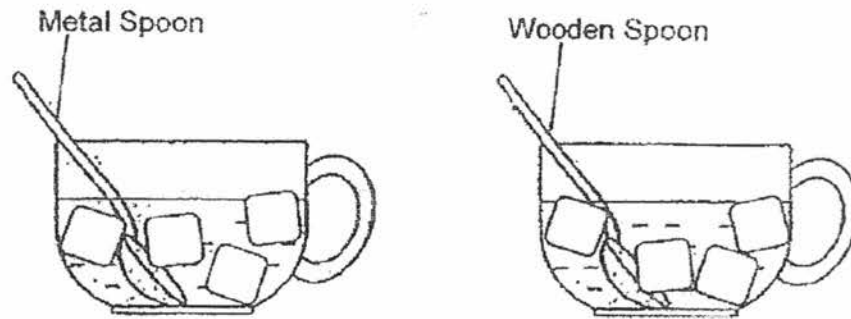

(b) Explain why the metal spoon felt much colder than the wooden spoon. [2]

End of Paper

Score	4
-------	---

EXAM PAPER 2017 (P5)

SCHOOL : Nan Hua

SUBJECT : SCIENCE

TERM : SA1

Q1	Q2	Q3	Q4	Q5	Q6	Q7	Q8	Q9	Q10
4	1	1	3	3	2	4	4	4	4
Q11	Q12	Q13	Q14	Q15	Q16	Q17	Q18	Q19	Q20
3	1	3	2	4	4	2	2	1	2
Q21	Q22	Q23	Q24	Q25	Q26	Q27	Q28		
2	2	1	2	2	4	3	3		

29)a)Part X:cell wall

Part Y:cell membrane

b)cell wall

30)a)The African Tulip will be dispersed further, because it's seed has a seed with wing-like structure that can kept it on the air longer than the Pea.

b)ovary

31)a)The sperm must fuse with the egg in order for fertilization to occur.

b)Nucleus

c)It contains genetic information from both parents.

32)a)The water level will increase

b) When the lady bug respired, it took in oxygen and gave out carbon dioxide. The carbon dioxide is absorbed by the substance causing the amount of air in the inverted beaker to decrease. The water will then occupy the space of the carbon dioxide.

33)a)i) Leaf cell: S

ii) Root cell: R

b) The leaf cell has chloroplast which contain chlorophyll to trap sunlight to photosynthesis but the root cell does not have chloroplast as it does not photosynthesis.

34)a)i) animal

ii) animal

b) As Plant A and C grow in the same area, Plant A has to compete with Plant C for space, water, light.

c)

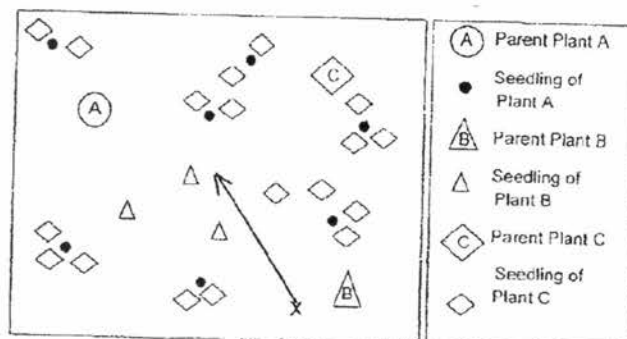

35)a) When the insect comes to find nectar, the pollen grain will stick onto the insect's body and it will land onto the stigma.

b) The flowers of the two types of tomatoes flower at different times.

c) Testes

d)

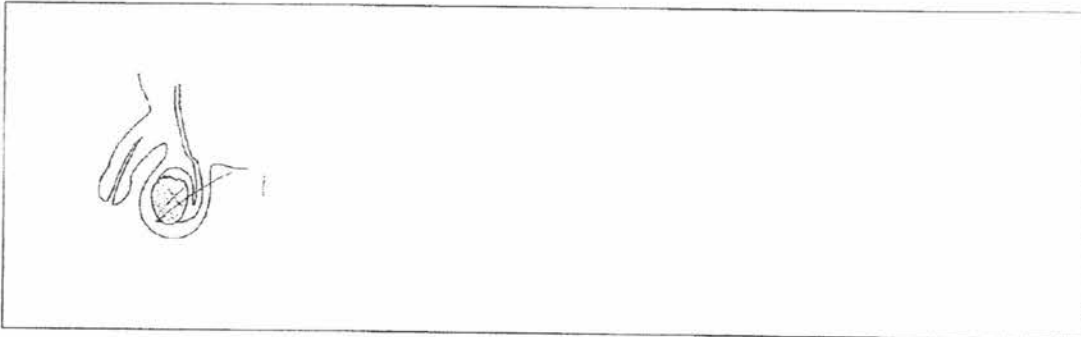

36)a)200

b)The purpose of the layer of oil is to prevent evaporation to occur and to ensure the water taken in is by the plants.

c)Set up A had taken in water by the roots.

37)a)i)Plastic is lighter so it will be easier to carry around.

ii)Plastic is stronger so that the bottle will not break when dropped.

b)Fabric B.It has the most amount of water collected in the beaker which shows it is most absorbent fabric.

c)size and thickness of the fabric

38)a)Dependent variable:number of paper clips attracted

Independent variable:number of coils of copper wire

b)In set-up A the number of coils around the iron rod is the highest,the resulting in the strongest magnetic.

c)Put in more batteries

d)No.Copper is non-magnetic material and cannot be magnetized.

39)a)The steam lost heat to the cooler surface of the plate and condense into water droplets.

b)More water will collected as the metal plate is colder.Steam will lose heat faster due to the greater temperature difference and speed up the rate of condensation.

c)The metal plate had gained heat from the steam and become hotter.This caused the temperature difference between the metal plates and steam to decrease resulting in a decrease in the rate of condensation.

40)a)Wood.The set-up with wood has the temperature of the water is the highest at the end so that the water loses heat to the surrounding the slowest.

b)The metal spoon is a better conductor of heat.Tom lost heat to the spoon and then the ice water faster.