

Anglo-Chinese School (Junior)



WEIGHTED ASSESSMENT 2 (2020)

PRIMARY 5

SCIENCE

BOOKLET A

Wednesday

19 August 2020

50 min

Name: _____ () Class: 5.()

INSTRUCTIONS TO PUPILS

- 1 Do not turn over the pages until you are told to do so.
- 2 Follow all instructions carefully.
- 3 There are 14 questions in this booklet.
- 4 Answer ALL questions.
- 5 Shade your answers in the Optical Answer Sheet (OAS) provided.

This question paper consists of 10 printed pages (inclusive of cover page).

For each question from 1 to 14, four options are given. One of them is the correct answer. Make your choice (1, 2, 3 or 4). Shade your answer on the Optical Answer Sheet.

(26 marks)

1. The graph shows the amount of food eaten by the young of Animal A during its life cycle.

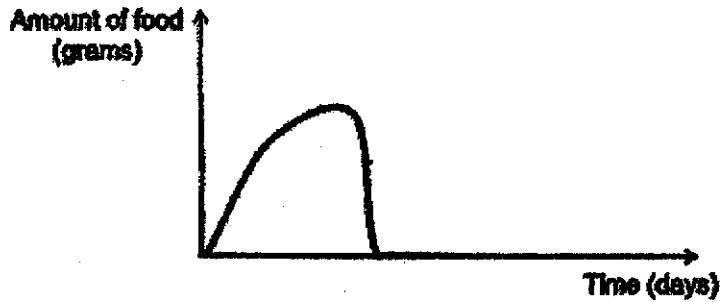

Animal A is most likely a _____.

- (1) frog
 (2) chicken
 (3) grasshopper
 (4) mealworm beetle
2. The diagrams show flowers of two similar plants, X and Y.

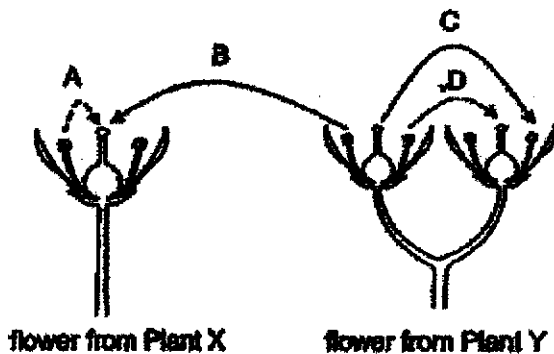

Which of the arrow(s) show(s) pollination taking place?

- (1) A only
 (2) C only
 (3) B and D only
 (4) A, B and D only

3. Diagrams X and Y show the human and plant reproductive systems.

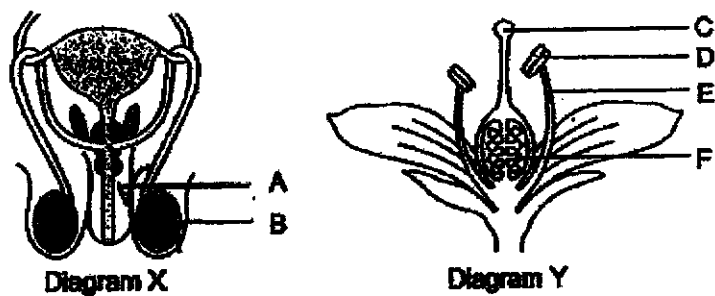

Which of the following correctly identifies the male and female parts of both systems?

| | Male parts | Female parts |
|-----|------------|--------------|
| (1) | A, B, C, F | D, E |
| (2) | A, B, D, E | C, F |
| (3) | C, D, E | A, B, F |
| (4) | D, E | A, B, C, F |

4. The diagram represents the continuous movement of water in the water cycle.

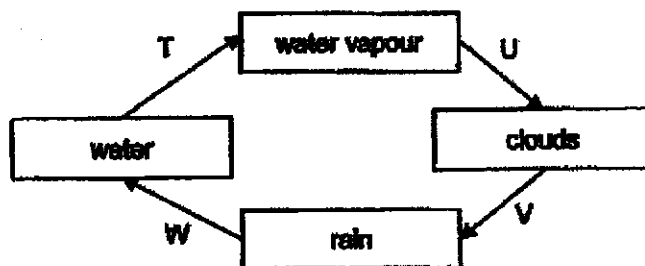

At which parts of the water cycle does a change in state occur?

- (1) W only
- (2) T and U only
- (3) T, U and V only
- (4) V and W only

5. Jane placed five pieces of cloth at different locations.

| Set-Up | Location | Material of cloth |
|--------|--------------------------|-------------------|
| A | In the refrigerator | silk |
| B | Inside a closed cupboard | cotton |
| C | In the open field | silk |
| D | In the refrigerator | cotton |
| E | Inside a closed cupboard | wool |

Which set-ups should she use to find out how the location of the set-ups affects how fast the cloths dry?

- (1) A and D
 (2) B and D
 (3) B and E
 (4) C and E
6. Alan set up an experiment with objects X, Y and Z. He placed each object near a magnet, a wooden spoon and an iron nail and observed the interactions between them. He recorded his observations in the table.

| Object | Observations | | |
|--------|----------------|----------------|----------------|
| | Magnet | Wooden spoon | Iron nail |
| X | attract | no interaction | no interaction |
| Y | repel | no interaction | attract |
| Z | no interaction | no interaction | no interaction |

Based on Alan's observations, which of the following are objects X, Y and Z?

| | X | Y | Z |
|-----|------------|------------|------------|
| (1) | magnet | copper bar | iron bar |
| (2) | copper bar | iron bar | magnet |
| (3) | copper bar | magnet | iron bar |
| (4) | iron bar | magnet | copper bar |

7. The diagram shows how substances X and Y are transported in the human body.

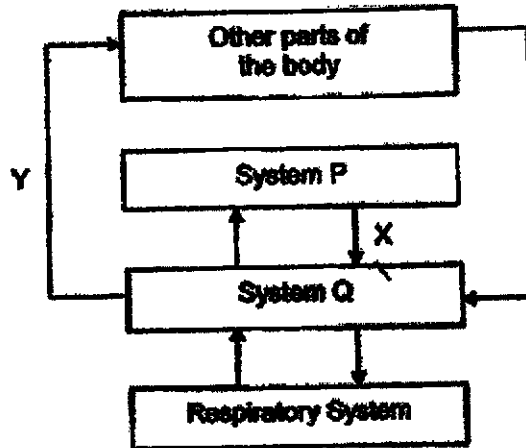

What are systems P and Q and substances X and Y?

| | System P | System Q | Substance X | Substance Y |
|-----|-------------|-------------|----------------|---------------|
| (1) | digestive | circulatory | digested food | oxygen |
| (2) | circulatory | digestive | carbon dioxide | water |
| (3) | digestive | circulatory | carbon dioxide | oxygen |
| (4) | circulatory | digestive | digested food | digested food |

8. Study the flowchart.

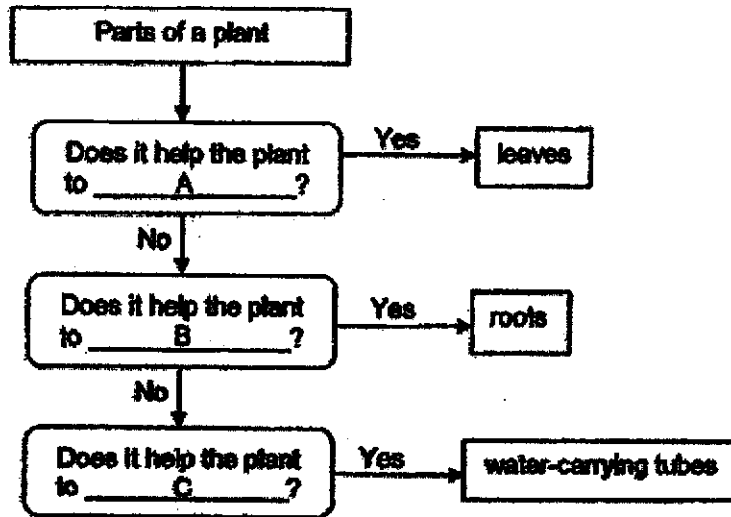

Which of the following correctly identifies A, B and C?

| | A | B | C |
|-----|----------------|-----------------------------|-------------------------|
| (1) | make food | absorb water | stay upright |
| (2) | exchange gases | anchor itself to the ground | transport water |
| (3) | make food | absorb mineral salts | transport glucose |
| (4) | exchange gases | stay upright | transport mineral salts |

9. Which of the bar graphs best represents the composition of oxygen, carbon dioxide and water vapour in the air inhaled and exhaled by humans?

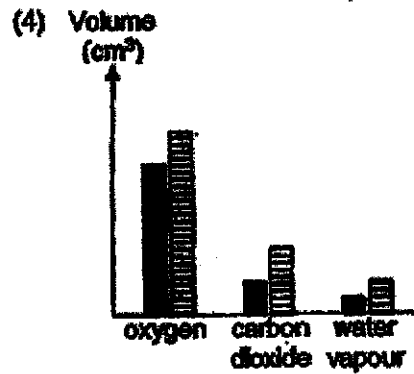
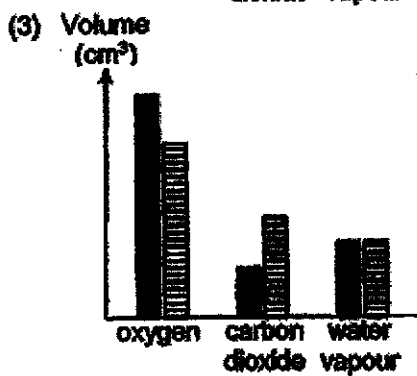
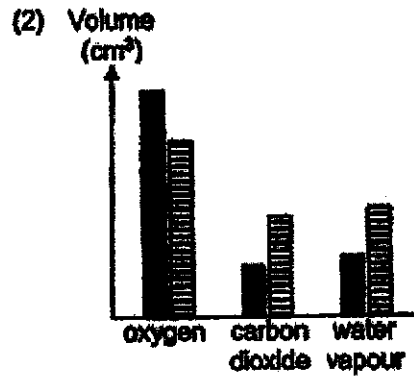
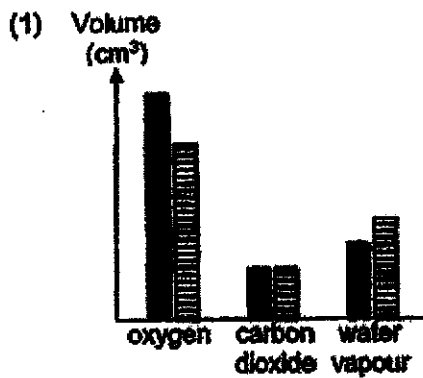
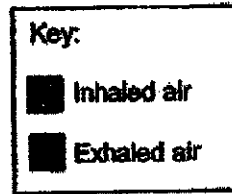

10. Which of the following is/are correct about the respiratory systems of a fish and a human?

| | Fish | Human |
|---|--------------------------------------------|--------------------------------------------|
| A | Gaseous exchange takes place at the gills. | Gaseous exchange takes place in the lungs. |
| B | Takes in dissolved oxygen in the water. | Takes in oxygen from the inhaled air. |
| C | Carbon dioxide is removed at the mouth. | Carbon dioxide is removed at the nose. |

- (1) A only
 (2) C only
 (3) A and B only
 (4) A and C only
11. Ross set up the following electric circuits using identical bulbs, wires and batteries, all in working condition.

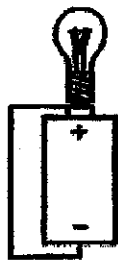

Circuit P

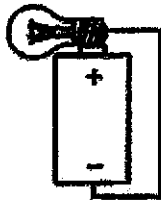

Circuit Q

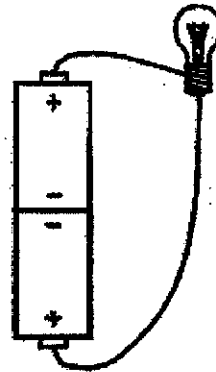

Circuit R

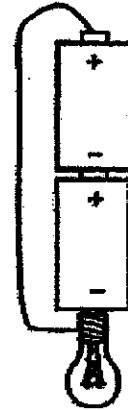

Circuit S

In which circuit(s) will the bulb(s) light up?

- (1) Q only
 (2) Q and S only
 (3) R and S only
 (4) P, R and S only

12. The diagram shows a cell.

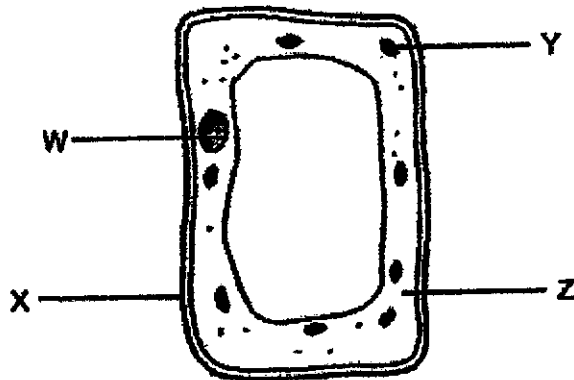

Which of the following statements about the function of cell parts are correct?

- A Part W controls all activities of the cell.
- B Part X supports and gives the cell its shape.
- C Part Y makes food for the cell.
- D Part Z controls the movement of substances in and out of the cell.

- (1) A and D only
- (2) B and C only
- (3) A, B and C only
- (4) B, C and D only

13. Object R is made out of cardboard.

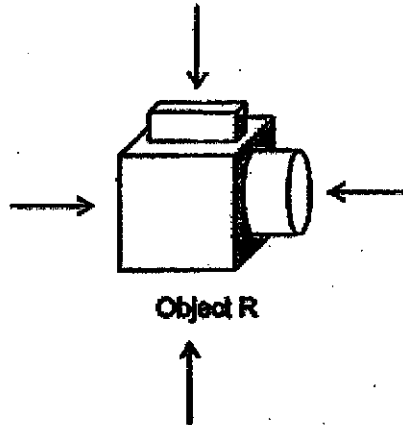

Which of the following shadows cannot be formed by object R when light is shone on it from different directions as shown by the arrows?

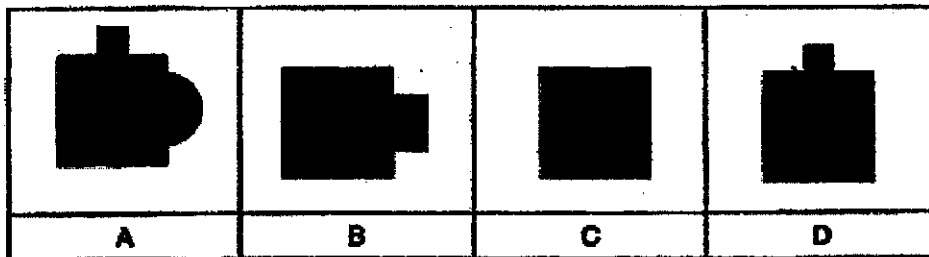

- (1) D only
 (2) B and D only
 (3) A and C only
 (4) A, B and C only
14. What happens when ice is melting?

- A It loses heat.
 B Its mass increases.
 C Its temperature increases.
 D There is a change in state.

- (1) D only
 (2) B and C only
 (3) C and D only
 (4) A, B and C only

End of Booklet A

Anglo-Chinese School (Junior)



WEIGHTED ASSESSMENT 2 (2020)

PRIMARY 5

SCIENCE

BOOKLET B

Wednesday

19 August 2020

50 min

Name: _____ () Class: 5.() Parent's Signature: _____

INSTRUCTIONS TO PUPILS

- 1 Do not turn over the pages until you are told to do so.
- 2 Follow all instructions carefully.
- 3 There are 7 questions in this booklet.
- 4 Answer ALL questions.
- 5 The marks are given in the brackets [] at the end of each question or part question.

| Booklet | Possible Marks | Marks Obtained |
|---------|----------------|----------------|
| A | 28 | |
| B | 22 | |
| Total | 50 | |

This question paper consists of 8 printed pages (inclusive of cover page).

For questions 15 to 21, write your answers in this booklet.
 The number of marks available is shown in brackets [] at the end of each question or part question.

(22 marks)

15. Dave placed some marbles in Container Y.

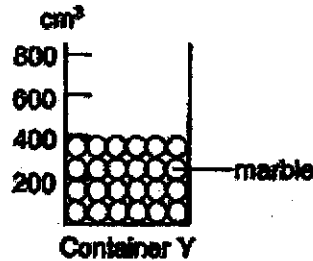

(a) Identify the states of matter in Container Y. [1]

(b) Dave poured 400 cm³ of water into Container Y.

Would the total volume of water and marbles in Container Y be more than, less than or equals to 800 cm³? Explain your answer. [1]

(c) Dave then placed bigger marbles into Container Z. Container Z is identical to Container Y.

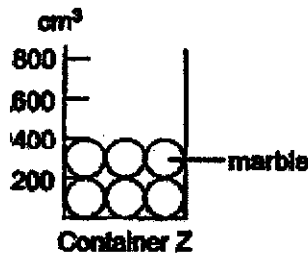

He poured 400cm³ of water into Container Z. Would the total volume of water and marbles in Container Z be more than, less than or equals to that in Container Y? Explain your answer. [1]

(Go on to the next page)

| | |
|-------|---|
| SCORE | 3 |
|-------|---|

16. Mdm Lim folded three similar sized towels and hung them out to dry in her garden as shown.

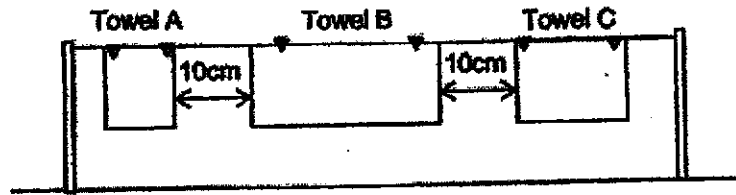

- (a) Which towel, A, B or C, dried the fastest? Explain your answer. [1]

- (b) State another variable that should be kept the same in this experiment to ensure a fair test. [1]

- (c) The graph shows how the amount of water in Towel C changed when it was hung out to dry in the garden on a cloudy day.

hung

Amount of water (ml)

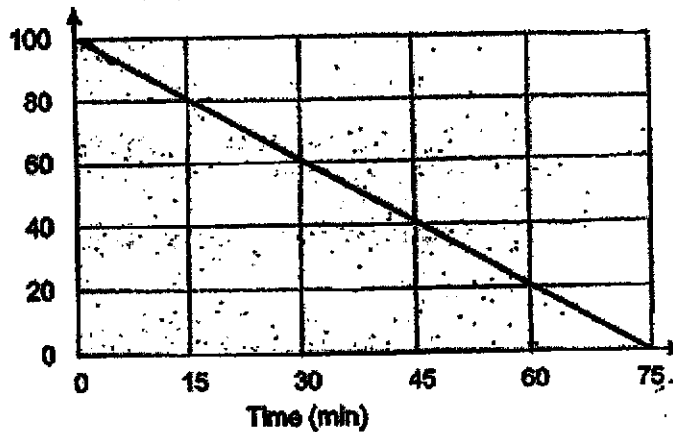

- Using a ruler, draw a line in the graph above to show how the amount of water in Towel C would change if the same towel was hung out to dry in the same garden on a sunny day. [1]

(Go on to the next page)

| | |
|-------|---|
| SCORE | 3 |
|-------|---|

17. Siti placed a plastic container of water at 60°C in a classroom at room temperature for 10 minutes as shown in set-up A.

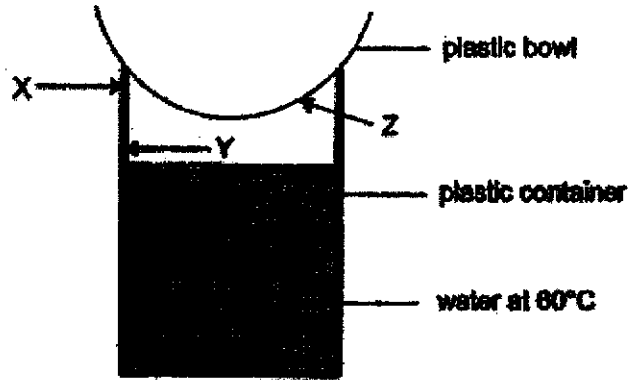

Set-up A

- (a) After five minutes, she observed water droplets forming in set-up A.
Which parts of the set-up, X, Y or Z, will water droplets likely be formed? [1]

- (b) Explain how the water droplets were formed. [2]

- (c) Without changing the plastic bowl, container and volume of water, suggest how water droplets can be formed faster in set-up A. [1]

(Go on to the next page)

| | |
|-------|---|
| SCORE | 4 |
|-------|---|

18. The diagram shows three different types of plants, A, B, and C, in a forest.

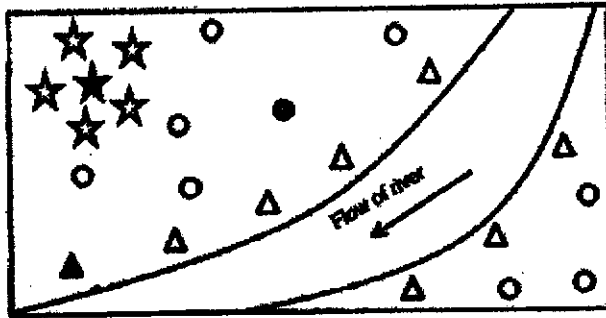

Key:

| Plant | Parent | Young |
|-------|--------|-------|
| A | ★ | ★ |
| B | ▲ | △ |
| C | ● | ○ |

(a) Circle the parent plant that is in the wrong position and give a reason for your answer. [1]

(b) State the method of seed/fruit dispersal of plants A, B and C in the table. [1]

| Plant | Method of dispersal |
|-------|---------------------|
| A | |
| B | |
| C | |

(c) State a characteristic of the seed/fruit of Plant C that helps in its dispersal. [1]

(Go on to the next page)

| | |
|-------|---|
| SCORE | 3 |
|-------|---|

19. The diagram shows the direction of blood flow in some parts of the body.

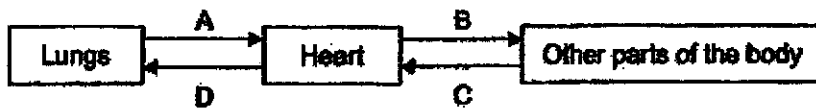

Vivian drew a bar graph to show the different amounts of oxygen found in the blood from A, B, C and D.

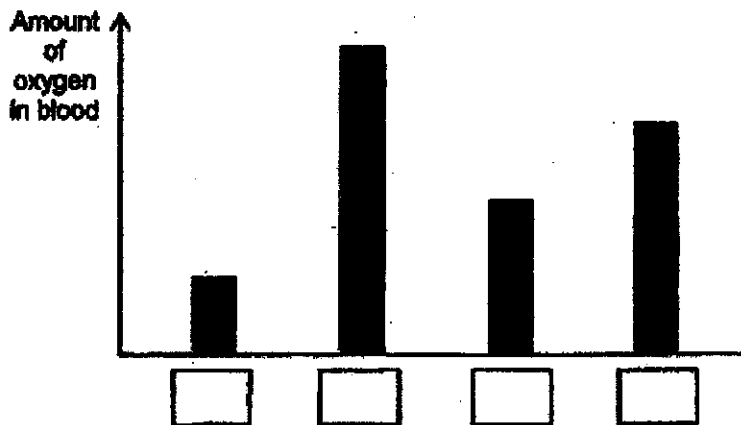

- (a) Label the bar graph with letters A, B, C and D. [1]
- (b) Vivian's heart rate increased when she went for a jog. Explain why. [2]

(Go on to the next page)

| | |
|-------|---|
| SCORE | 3 |
|-------|---|

20. Jake made a circuit card using steel paper clips, A, B, C, D, E and F, and some wires.

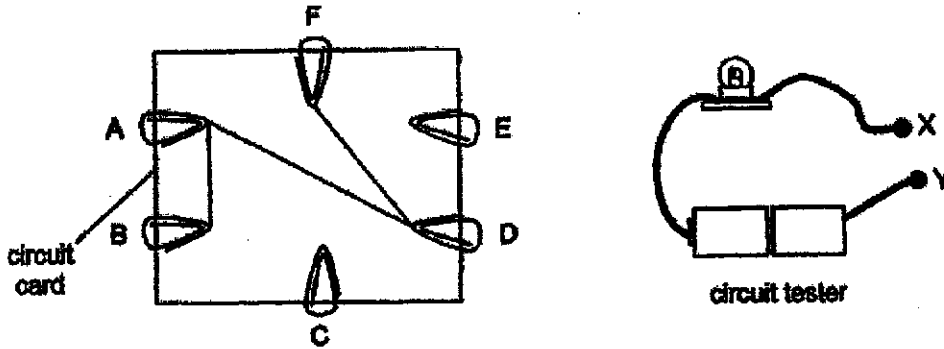

- (a) He then used a circuit tester to find out which clips when connected to the circuit tester at points X and Y will allow the bulb to light up. Fill in the table with a "Yes" if the bulb will light up or "No" if it will not light up. [2]

| Clips tested | Does the bulb of circuit tester light up? |
|--------------|-------------------------------------------|
| A and B | |
| A and F | |
| B and D | |
| C and E | |

- (b) Jake then prepared two set-ups with two different objects, P and Q.

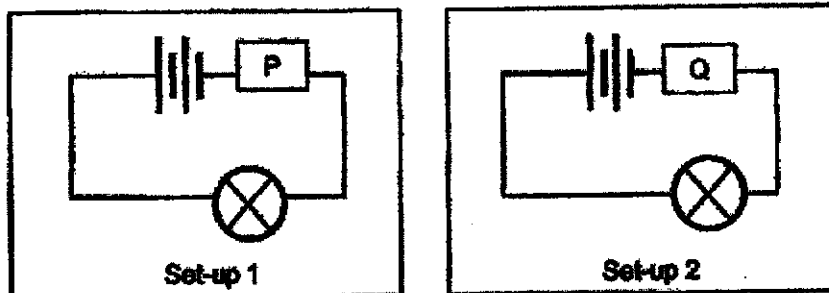

- Object P is a wooden chopstick and object Q is a copper pipe. In which set-up, 1 or 2, will the bulb light up? Explain your answer. [1]

(Go on to the next page)

| | |
|-------|---|
| SCORE | 3 |
|-------|---|

21. The diagram shows three identical containers made of different materials X, Y and Z. Each container has the same amount of water. The containers are placed on a heating plate.

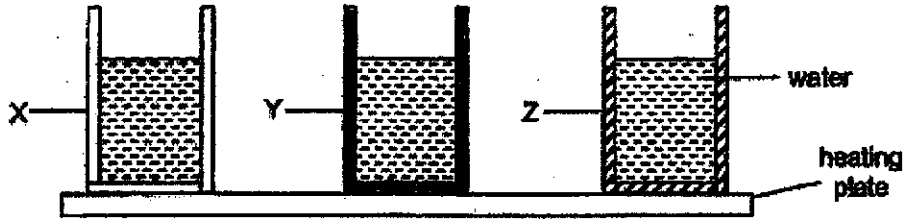

After 15 minutes, the amount of water left in the containers is as shown.

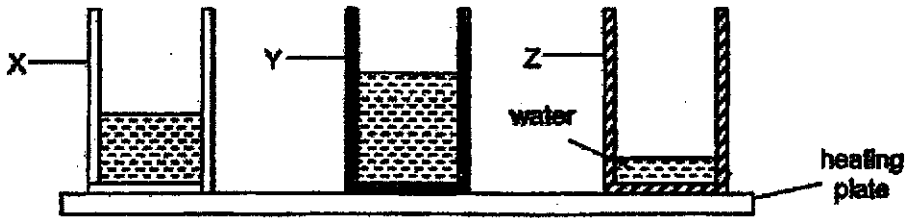

- (a) What can you conclude about Material Z? Explain your answer. [2]

- (b) The diagram shows cold liquid R which is transported through pipes in an air conditioning system.

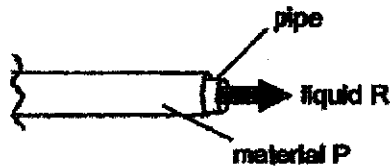

The pipes are covered with material P that allows liquid R to be at the lowest possible temperature so that it can cool the room.

- Which material, X, Y or Z, should material P be made of? Explain how it allows liquid R to be at the lowest possible temperature. [1]

| | |
|-------|---|
| SCORE | 3 |
|-------|---|

SCHOOL : ANGLO – CHINESE SCHOOL (JUNIOR)
 LEVEL : PRIMARY 5
 SUBJECT : SCIENCE
 TERM : 2020 CA2

SECTION A

| | | | | | | | | | |
|------|-----|-----|-----|----|----|----|----|----|-----|
| Q 1 | Q2 | Q3 | Q4 | Q5 | Q6 | Q7 | Q8 | Q9 | Q10 |
| 4 | 4 | 2 | 2 | 2 | 4 | 1 | 2 | 2 | 3 |
| Q 11 | Q12 | Q13 | Q14 | | | | | | |
| 2 | 3 | 3 | 1 | | | | | | |

SECTION B

| | |
|------|---------------------------------------------------------------------------------------------------------------------------------------------------------------------------------------------------------------------------------------------------------------------------------------------------------------------------------------------------------------------------------------------------------------------------------------------|
| Q15) | <p>(a) Gas and solid</p> <p>(b) Less than 800cm³. Less water displaces the air in the spaces between the marbles.</p> <p>(c) It would be less than the volume of water and marbles in container Y. When bigger marbles are placed in container Z, the air spaces between the marbles are bigger so the total volume of water and marbles would be less than in Y when 400cm³ of water is poured into container Z.</p> |
| Q16) | <p>(a) Towel B. It had the most surface area exposed to the surroundings so the evaporation of water from the towel is the fastest. Thus, it dried the faster.</p> <p>(b) Wind blowing at the towel</p> <p>(c)</p> <div style="text-align: center;"> </div> |

| | |
|------|--------------------------------------------------------------------------------------------------------------------------------------------------------------------------------------------------|
| Q17) | <p>(a) Y and Z</p> <p>(b) The water at 60°C evaporated into warm water. The warmer water vapour would come into contact with the cooler surface, lose heat and condense into water droplets.</p> |
|------|--------------------------------------------------------------------------------------------------------------------------------------------------------------------------------------------------|

| | |
|------|-----------------------------------------------------------------------------------------------------------------------------------------------------------------------------------------------------------------------------------------------------------------------------------------------------------------------------------------|
| | (c) Add ice on the plastic bowl, use hotter water in the container. |
| Q18) | <p>(a) The parent plant should not be at the bottom of the river. It should be at the start of the river flow so during dispersal, its seeds can drift to the riverbank.</p> <p>(b) Splitting Water Wind</p> <p>(c) It has wing like structure so it can get blown by the wind to a further distance from the parent plant.</p> |
| Q19) | <p>(a) $DD \rightarrow AA \rightarrow CC \rightarrow BB$</p> <p>(b) When the heart pumps faster, more blood would be pumped and oxygen to all parts of the body faster to release more energy.</p> |
| Q20) | <p>(a) Yes Yes Yes No</p> <p>(b) Set up Z. Copper is a conductor of electricity so electric current can flow in a closed circuit and the bulb would light up.</p> |
| Q21) | <p>(a)) Material Z is the best conductor. It conducted heat from heating plate to the water the fastest. The water in material Z gained heat faster and the rate of evaporation was the fastest.</p> <p>(b) Material Y. It would gain heat from the surrounding the slowest.</p> |

