

**NANYANG PRIMARY SCHOOL**  
**PRIMARY 6 SCIENCE**  
**FIRST CONTINUAL ASSESSMENT 2005**

Name : \_\_\_\_\_ ( )      Date : \_\_\_\_\_

Class : Primary 6 ( )      Duration : 1 h 45 min

Parent's signature: \_\_\_\_\_      Score :

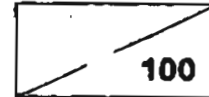

Settlers : Mrs Lynette Wong & Mr Ting Huat Seng

**Section A** (30 x 2 marks = 60 marks)

For each question from 1 to 30, four options are given. One of them is the correct answer. Make your choice (1, 2, 3 or 4). Shade the correct oval (1, 2, 3 or 4) on the Optical Answer Sheet provided.

1. Gina classified some organisms into 3 groups.

Group A	Group B	Group C
mimosa	toadstool	woodlouse
rain tree	bracket fungus	millipede

How did she group the organisms?

- A according to their nutrition  
 B according to their habitat  
 C according to the way they reproduce

- (1) A and B only  
 (2) B and C only  
 (3) A and C only  
 (4) A, B and C

2. Which one of the following features is likely to be found in an insect-pollinated flower?

- (1) A feathery stigma
- (2) Sticky pollen grains
- (3) Long-hanging stamens
- (4) Petals reduced or absent

3. The following plants are classified according to how their seeds are dispersed.

Group X	Group Y	Group Z
coconut	guava	angsana
mangrove	chilli	vernonia

Which one of the following groups of fruits shown below is classified according to the way shown above?

	Group X	Group Y	Group Z
(1)	nipah	water-melon	lotus
(2)	balsam	lady's finger	African tulip
(3)	pong-pong	love-grass	shorea
(4)	lotus	lalang	casuarina

4. The diagram below shows Lina's family tree.

Male □  
Female ○

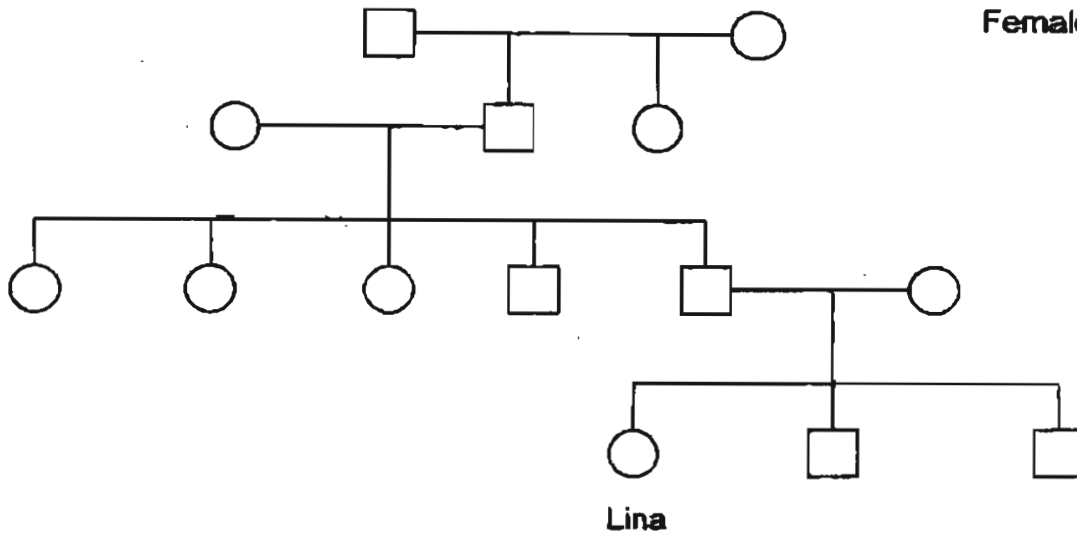

Which one of the following statements about Lina's family is true?

- (1) Lina has two uncles.
- (2) Lina has one younger sister.
- (3) Lina's father has three sisters.
- (4) Lina's great-grandparents have three children.

5. Which of the following animals do not go through the pupal stage in their life-cycles?

- A Housefly
- ~~B~~ Grasshopper
- ~~C~~ Cockroach
- ~~D~~ Dragonfly

- (1) A and B only
- (2) A, B and C only
- (3) A, C and D only
- (4) B, C and D only

6. Which of the following are found in the female reproductive system?

- ~~(1)~~ Uterus, sperm, testis, ova
- ~~(2)~~ Ovary, womb, vagina, ovum
- ~~(3)~~ Ova, testis, womb, fallopian tubes
- ~~(4)~~ Fallopian tubes, stomach, womb, ovary

7. The diagram below shows the life-cycle of an insect and the point at which fertilisation occurs.

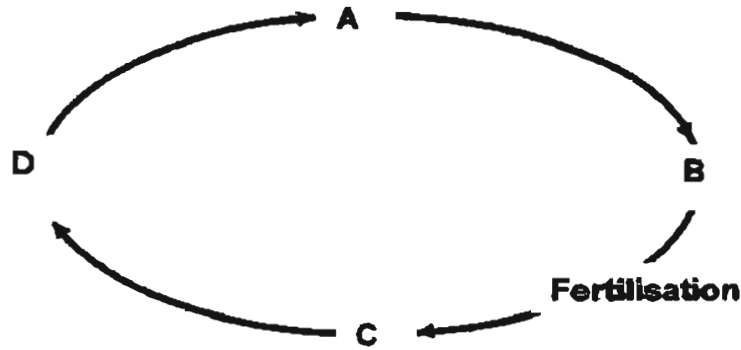

Which of the following are correct stages of the life-cycle?

	A	B	C	D
(1)	Egg	Larva	Pupa	Adult
(2)	Larva	Pupa	Adult	Egg
(3)	Pupa	Adult	Egg	Larva
(4)	Adult	Larva	Egg	Pupa

8. The diagram below shows the cross-section of a flower.

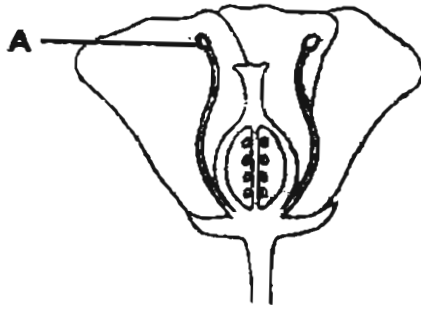

The part marked 'A' \_\_\_\_\_.

- (1) contains ovules
- (2) develops into a fruit
- (3) contains pollen grains
- (4) receives pollen grains

9. Study the classification chart below.

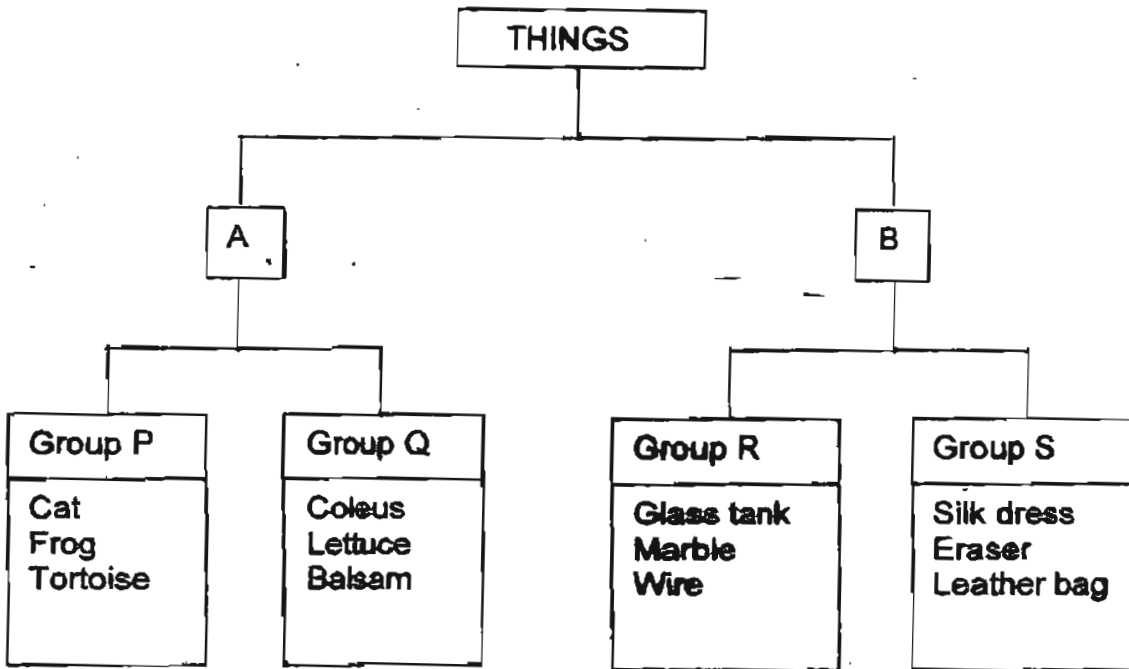

In which of the groups above would you place 'Venus flytrap' and 'ivory comb' respectively?

- (1) P and Q
- (2) P and S
- (3) Q and R
- (4) Q and S

10. The diagram below shows the structures inside a tomato fruit.

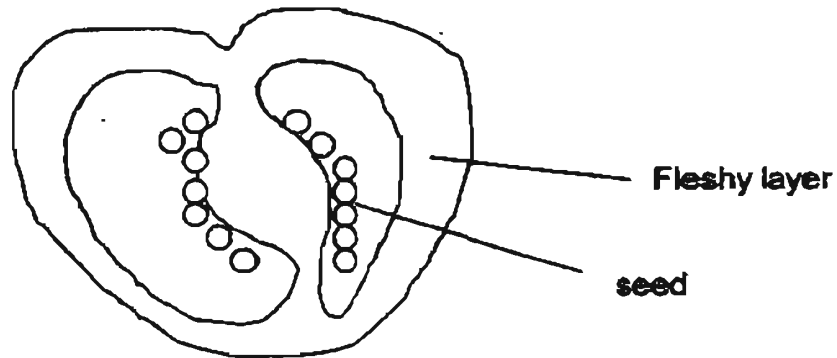

Which part of the tomato flower swells to form the fleshy layer of the fruit?

- (1) Ovule
- (2) Stigma
- (3) Stamen
- (4) Ovary wall

11. The diagram below shows a method of growing new plants.

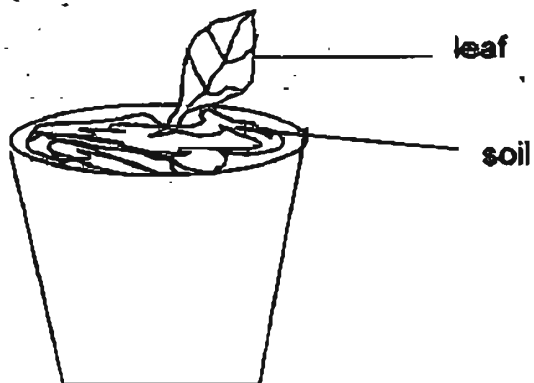

Which one of the following groups of plants can be grown by this method?

- (1) balsam and orchid
- (2) hibiscus and dumbcane
- (3) bryophyllum and coleus
- (4) begonia and sansevieria

12. Which one of the following organisms may have more than one cell?

- (1) Algae
- (2) Yeast
- (3) Bacterium
- (4) Paramecium

13. Oil can be extracted from \_\_\_\_\_.

- A olive fruit
- B soybeans
- C oil palm seed
- D groundnut seeds

- (1) A only
- (2) A and C only
- (3) A, B and D only
- (4) A, B, C and D

14. Study the classification table below.

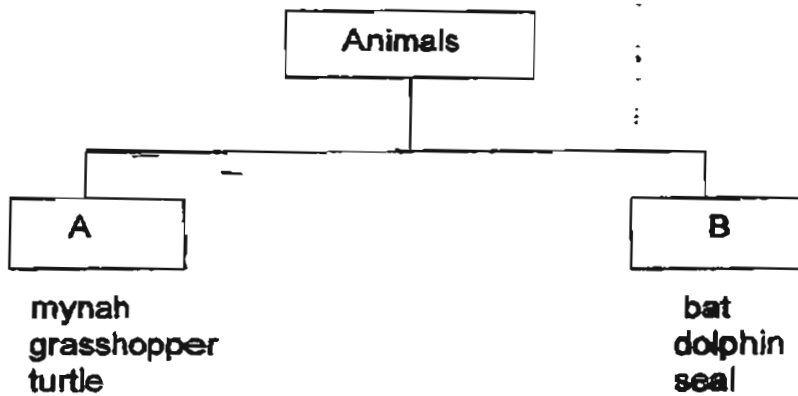

Which of the following headings best fit A and B respectively?

	A	B
(1)	Insects	Mammals
(2)	Lay eggs	Give birth
(3)	Live on land	Live in water
(4)	Have 3-stage life cycle	Have 4-stage life cycle

15. An experiment was set up using 4 groups of insect-pollinated flowers of the same species in a field. At the start of the experiment, different parts of the flowers were removed, as shown in the table below. Insects were observed to be visiting the flowers freely.

Group of flowers	Stigma	Anthers	Petals
P	Present	Removed	Present
Q	Present	Present	Removed
R	Removed	Present	Removed
S	Removed	Removed	Present

Which group of flowers, P, Q, R or S, would produce the most seeds after 2 weeks?

- (1) P
  - (2) Q
  - (3) R
  - (4) S
16. What is the route taken by a pollen tube after pollination of a flower?

- (1) stigma → style → ovule
- (2) filament → stigma → style
- (3) ovule → style → stigma
- (4) stigma → filament → ovule





17. The table below contains some information about five planets.

Planets	Number of moons	Surface	Speed around Sun (km/s)	Distance from Sun (millions of km)
Mercury	0	solid	48	58
Earth	1	solid	30	150
Jupiter	15	gas	13	778
Neptune	6	gas	5	4496
Pluto	1	solid	5	5946

These tables show how Jane and Siti grouped these planets.

Jane	
Group 1	Group 2
Mercury	Jupiter
Earth	Neptune
Pluto	

Siti	
Group 1	Group 2
Mercury	Neptune
Earth	Pluto
Jupiter	

What characteristics did Jane and Siti use to group the planets?

	Jane	Siti
(1)	surface	distance from the sun
(2)	speed around the sun	distance from the sun
(3)	surface	number of moons
(4)	speed around the sun	number of moons

18. Which one of the following is not necessarily an effect as a result of day and night caused by the rotation of the earth ?

- (1) A bat looking for food.
- (2) Plants undergoing photosynthesis.
- (3) Water heated up by a solar heater.
- (4) The lights in the house are switched on.

19. Which one of the following is not a source of light ?

- (1) A star
- (2) A barbeque fire
- (3) The Moon
- (4) Fireworks in the sky

20. Study the diagram below.

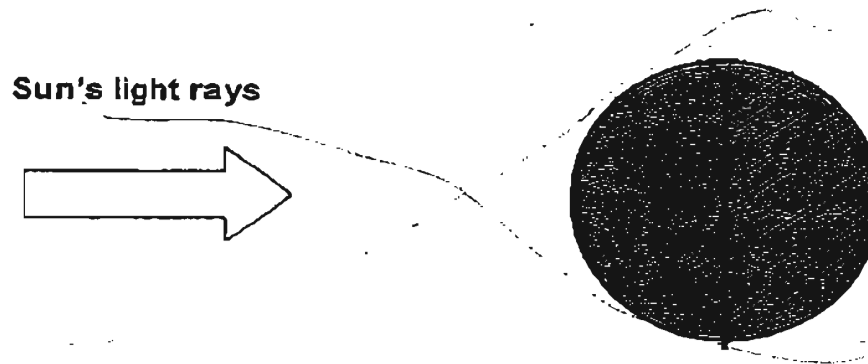

Which one of the following statements best describes what is happening to the Earth ?

- (1) Light from the Sun travels in straight lines.
- (2) The Earth is experiencing a Solar Eclipse.
- (3) Light from the Sun is passing through the Earth.
- (4) The whole Earth is reflecting the Sun's light rays.

21. The picture below shows the inside of a building with light coming through large windows at the roof.



Which one of the following statements best describes a property of light shown in the picture?

- (1) Light is reflected.
- (2) Light is absorbed.
- (3) Light travels in straight lines.
- (4) Light travels in many beams.

22. The shape of different shadows changes with the position of the light source.

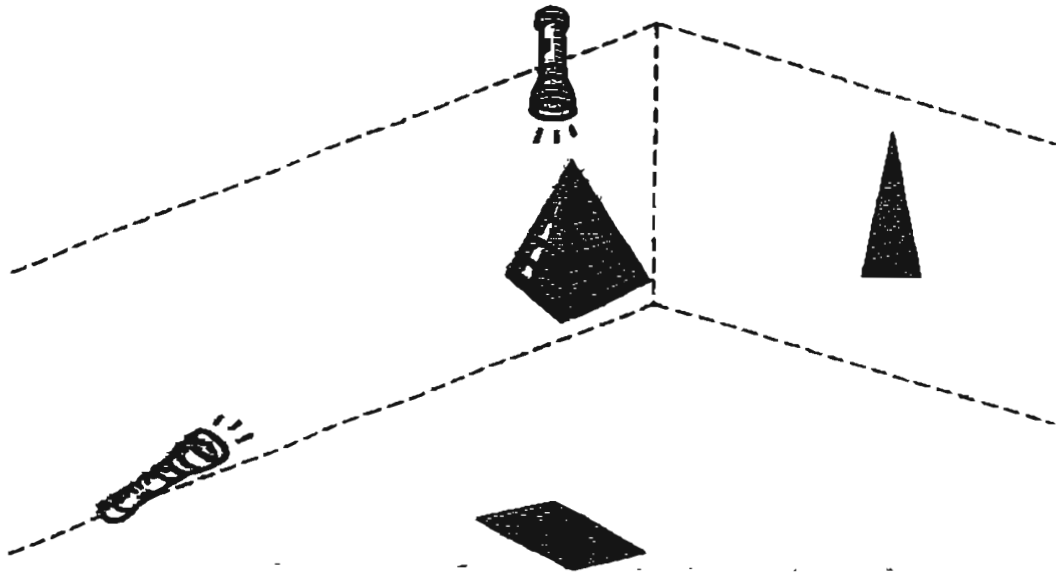

Study the two shadows shown below.



Which one of the following objects could produce these shadows ?

(1)



(2)

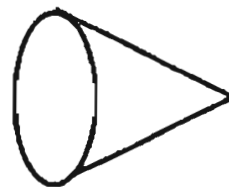

(3)



(4)





26. The drawing below shows a stove operated with a gas cartridge.

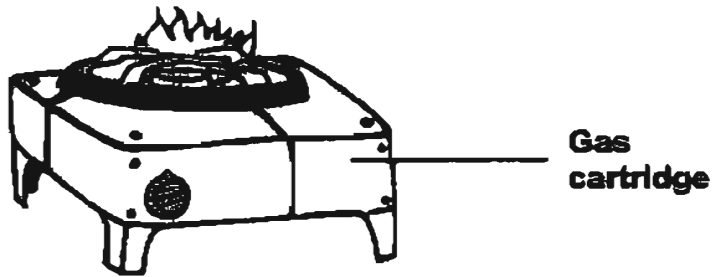

What forms of energy are present in the setup above ?

- (1) Heat and light energy
- (2) Potential and kinetic energy
- (3) Kinetic, heat and light energy
- (4) Potential, heat and light energy

27. Study the following information in the table below.

Appliance	Useful Energy	Energy that is not useful
A	light and sound	heat
B	heat	light
C	light	heat

Which of the following best identified the appliances ?

	Appliance A	Appliance B	Appliance C
(1)	toaster	television set	fluorescent light
(2)	television set	toaster	fluorescent light
(3)	fluorescent light	television set	toaster
(4)	toaster	fluorescent light	television set

28. Study the drawing of an experiment shown below.

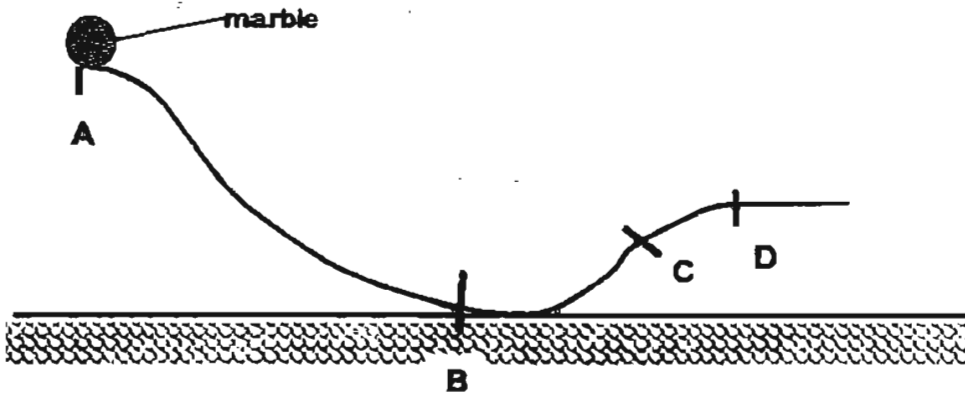

A marble is placed at the top of a slope at point A as shown in the drawing above. It is then allowed to roll down the slope from A. Which one of the following graphs best describes the changes in the amount of potential and kinetic energy of the marble from point A to point D?



(1)

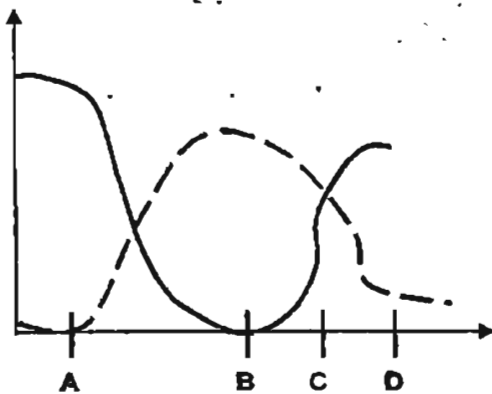

(2)

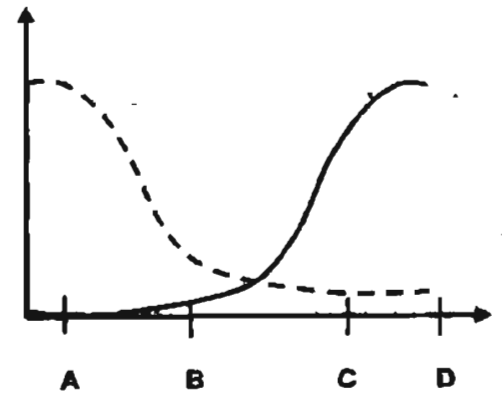

(3)

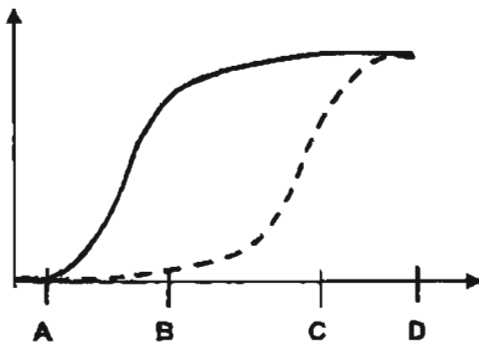

(4)

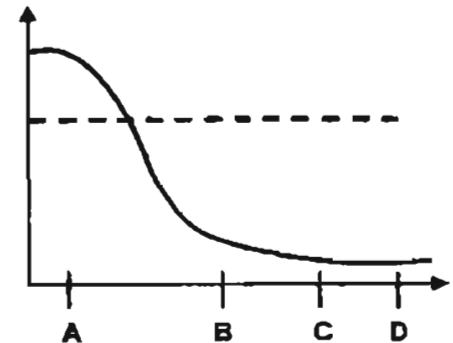

29. Study the following circuit diagram carefully.

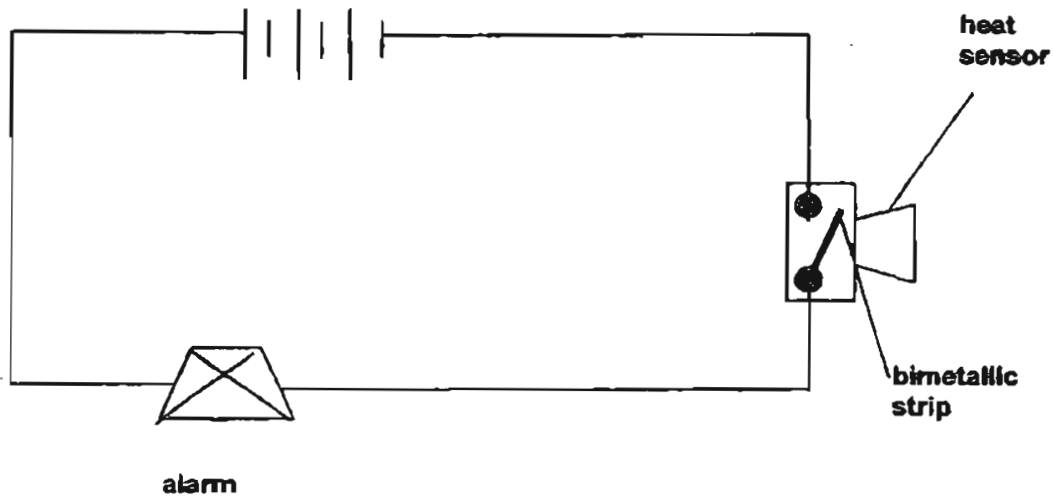

The heat sensor is able to detect temperatures between  $80^{\circ}\text{C}$  and  $110^{\circ}\text{C}$  before the alarm is activated. This happens when the bimetallic strip closes the circuit when it expands.

Which one of the following energy changes best describes what happens when a beaker of boiling water is brought near to the heat sensor ?

- (1) Heat Energy  $\rightarrow$  Kinetic Energy  $\rightarrow$  Electrical Energy  $\rightarrow$  Sound Energy
- (2) Kinetic Energy  $\rightarrow$  Electrical Energy  $\rightarrow$  Heat Energy  $\rightarrow$  Sound Energy
- (3) Kinetic Energy  $\rightarrow$  Sound Energy  $\rightarrow$  Heat Energy  $\rightarrow$  Electrical Energy
- (4) Electrical Energy  $\rightarrow$  Sound Energy  $\rightarrow$  Heat Energy  $\rightarrow$  Kinetic Energy

30. Study the diagram of a catapult below.

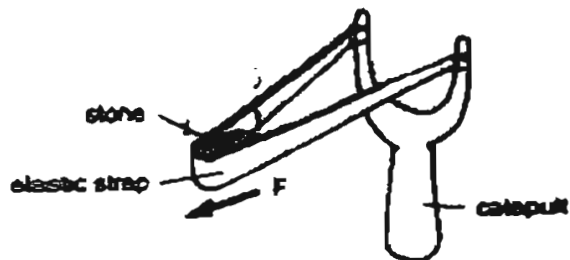

Which two of the following hypothesis are most likely to be correct ?

	How far the elastic strap is pulled back ?		Amount of potential energy	
	Further back	Not as far back	Greater	Lesser
A				
B				
C				
D				

- (1) A and B only
- (3) B and D only

- (2) A and C only
- (4) C and D only



NANYANG PRIMARY SCHOOL

PRIMARY 6 SCIENCE

FIRST CONTINUAL ASSESSMENT 2005

Name : \_\_\_\_\_ ) Date \_\_\_\_\_

Class : Primary 6 ( )

---

**Section B (40 marks)**

Write your answers to questions 31 to 46 in the spaces provided.  
Marks will be deducted for misspelt key words.

31: Study the classification below.

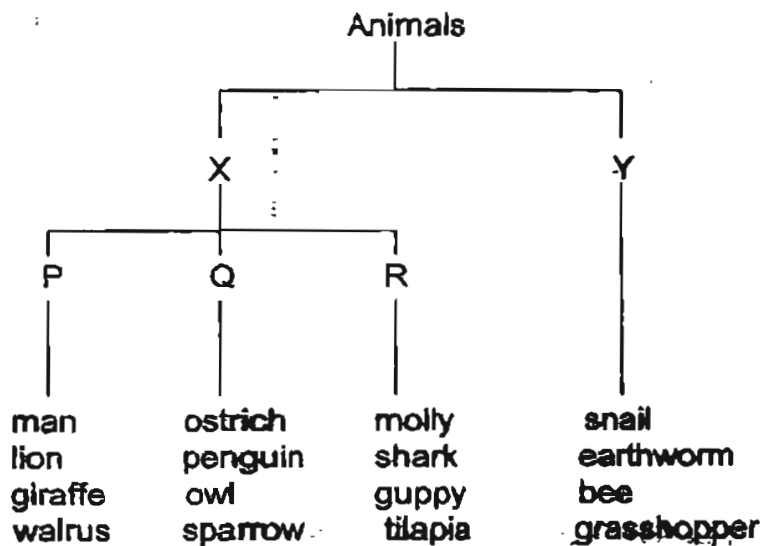

(a) Give a suitable heading for ' X '. (1 mark)

---

(b) State one characteristic feature of the animals in group ' Q '. (1 mark)

---

32. (a) State one use of the stomata found on leaves. (1 mark)

---

(b) In most plants, stomata are found on the underside of the leaves.

Give a reason why most of the stomata of the water-lilies are found on the upperside of their leaves. (1 mark)

---

---

---

33. Study the diagrams of the two animals shown below.



Animal A



Animal B

Based on what you can see in the diagrams, state one similarity and one difference between the two animals. Do not mention the shape or size of the animals. (2 marks)

(a) Similarity : \_\_\_\_\_

\_\_\_\_\_

(b) Difference : \_\_\_\_\_

\_\_\_\_\_

34. Mike carried out an experiment as follows:

Step 1: He dropped an angšana fruit from a height and recorded the time taken by the fruit to reach the ground. He repeated the step and calculated the average time taken by the angšana fruit to reach the ground.



Step 2: Next, he cut away the wing-like structure of the angšana fruit. He carried out step 1 with the 'wingless' angšana fruit.



(a) Mike recorded his results as shown in the table below. From the results of the experiment, identify the correct fruit by writing 'with wing-like structure' and 'without wing-like structure' in the boxes provided. (1 mark)

Angšana fruit	Time (seconds) taken			
	1 <sup>st</sup> Try	2 <sup>nd</sup> Try	3 <sup>rd</sup> Try	Average
	3.4	2.8	3.1	3.1
	5.2	5.6	5.1	5.3

(b) How does the wing-like structure help the angšana fruit to disperse? (1 mark)

---

---

35. Susan carried an experiment using four different liquids, J, P, R and S. She poured the different liquids into separate similar containers A, B, C and D. All four liquids do not mix with one another, as shown in the diagrams below.

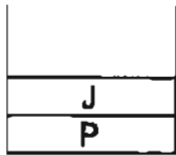

Container  
A

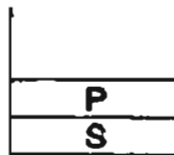

Container  
B



Container  
C

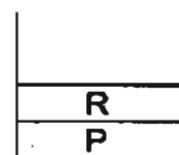

Container  
D

If all the four different liquids are poured into another container, show how the liquids will settle by writing the letters (J, P, R and S) in the diagram below.

(2 marks)

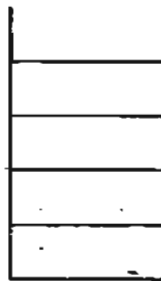

36. The diagram shows some stages in photosynthesis.

Substance X  
absorbed from  
atmosphere

Substance Y  
manufactured in  
leaf



Substance Z  
released to atmosphere

- (a) What are substances X, Y and Z?

(1 mark)

X: \_\_\_\_\_

Y: \_\_\_\_\_

Z: \_\_\_\_\_

- (b) Describe what happens to excess substance Y manufactured. (1 mark)

---

---

---

37. The diagram below shows a seedling.

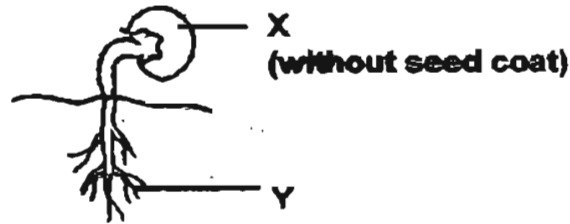

- (a) In what way is the part labelled X useful at this stage of its growth? (1 mark)

---

---

- (b) What is the function of Y? (1 mark)

---

---

- (c) State the conditions which are necessary for the seed to grow into a seedling. (1 mark)

---

---

38. The diagram below shows the different parts of a typical plant cell.

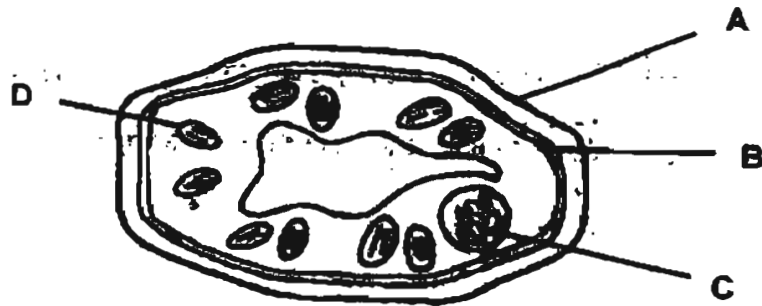

In the table below, state the functions of the parts labelled A, B, C and D. (4 marks)

Parts	Functions
A	
B	
C	
D	

39. Plants make food. Other organisms eat plants and other organisms for food.

The main source of energy for living things is the sun. Plants use energy from the sun to make food through the process of \_\_\_\_\_. A lamp is similar to the sun because it also gives out \_\_\_\_\_ and \_\_\_\_\_ energy. A lamp converts these forms of energy from \_\_\_\_\_ energy with the help of a bulb. Therefore, both the sun and the lamp are different sources of energy. (2 mark

40. The diagram below shows a boy cycling up 2 slopes of the same surface.

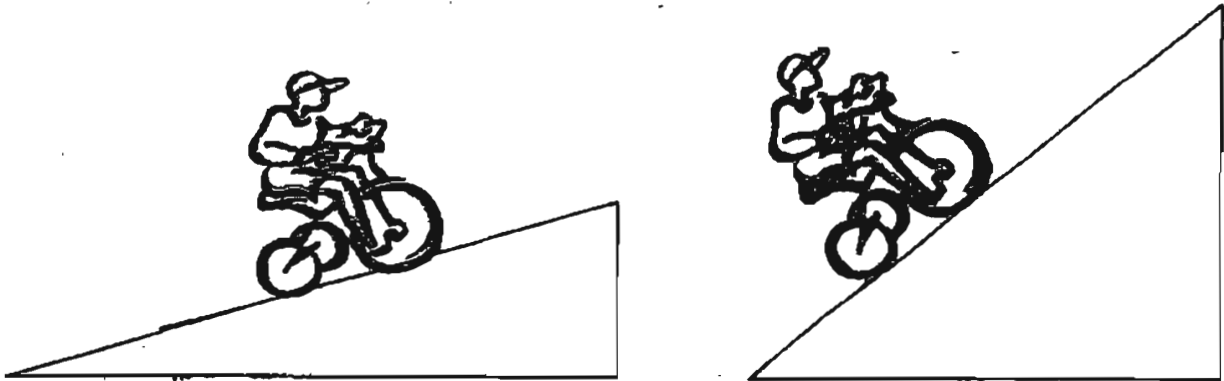

(a) Where did the boy get the energy to enable them to cycle up the slopes? (1 mark)

---

(b) What is the difference between the potential energy of the boy at the top of the slope compared to that when he was at the bottom? (1 mark)

---

---

---

41. Mariam set up the following experiment to measure the change in temperature over ten minutes at 2 minutes intervals when four types of heating coil were used.

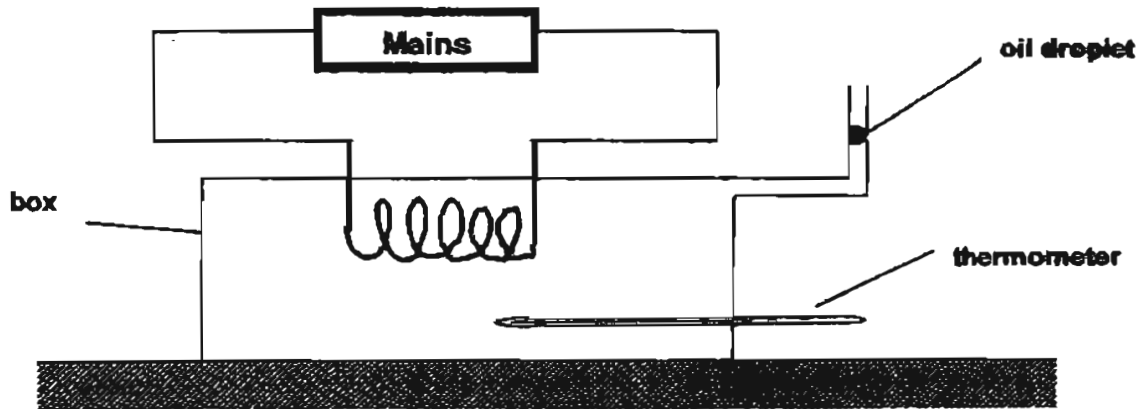

The table below shows the results that she obtained.  
 Temperature of air before the start of the experiment was 30°C

Material of Heating Coil	Temperature Change (°C)				
	2 minutes	4 minutes	6 minutes	8 minutes	10 minutes
Copper	30	35	40	43	45
Nichrome	30	42	48	57	65
Tin	30	30	32	33	33
Steel	30	30	30	31	32

- (a) What is the energy change that has taken place during the experiment?

Write the forms of energy in the boxes provided.

(1 mark)

(mains)

(coil)

(oil droplet)

- (b) Based on the results, which material is best suited to be used as a heating element in a heater to warm up a room in winter? (1 mark)

---

- (c) Explain your answer in (b).

(1 mark)

---



---



42. Study the diagram below.

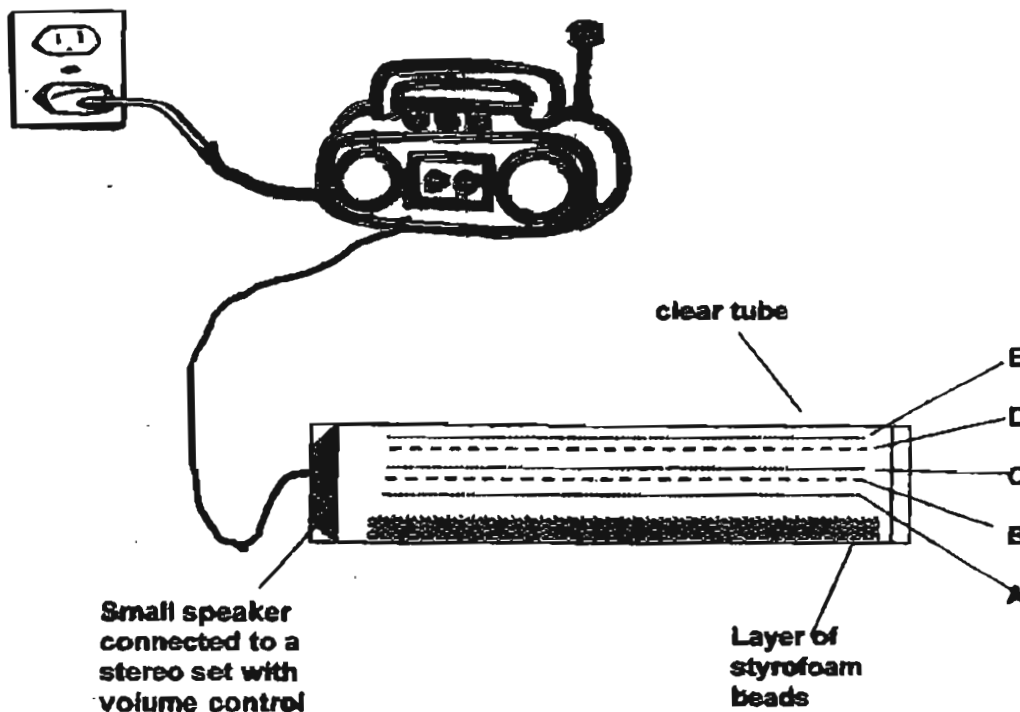

To conduct the experiment, Jie Wei set the volume of the stereo at the 5<sup>th</sup> marking before switching it on. When that happened, the styrofoam beads would vibrate and jump about in the tube. He noted the maximum height reached by the beads. Then, he repeated the experiment setting the volume at 10<sup>th</sup>, 15<sup>th</sup> and 20<sup>th</sup> marking.

(a) What was the aim of the experiment? (1 mark)

---



---

(b) The markings A to E on the tube showed the average height jumped by the beads under different volume settings.

Complete the table below by writing the appropriate volume settings, 5<sup>th</sup>, 10<sup>th</sup>, 15<sup>th</sup> and 20<sup>th</sup>, in the correct columns. (1 mark)

Height jumped by beads	A	B	C	D	E
Volume setting					

43. Julian used the light probe from the school's datalogger set for an experiment. The light probe measured the amount of light that passed through the material. Before he started his experiment, he learned that 'Lux' is the unit to measure how much light had been detected by the light probe.

He set up the experiment as shown below.

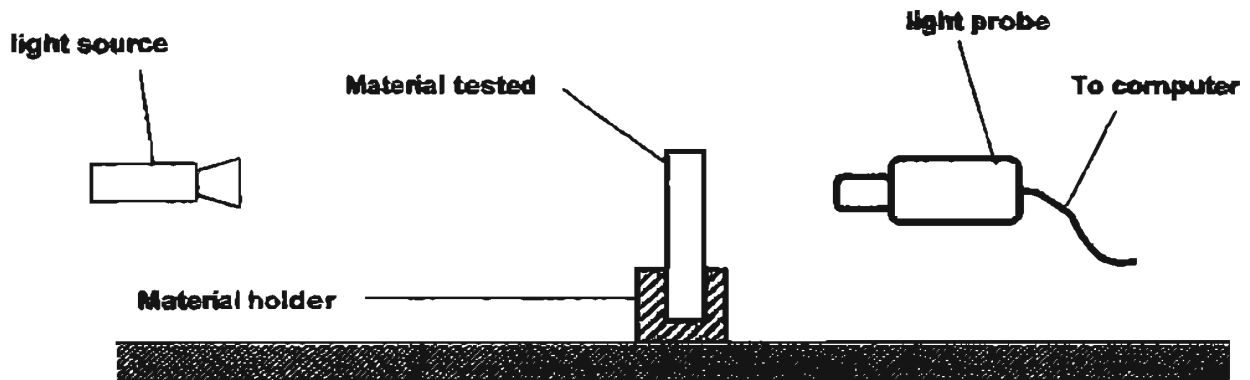

Julian recorded his results in the table below.

Material	Amount of light detected (Lux)
A	70
B	20
C	0

- (a) Based on the above results, which material is opaque? Explain your answer. (2 mark)

---



---

- (b) What would happen to the amount of light detected by the probe when the light source is moved further back from the material? (1 mark)

---



---

44. Study the following diagram carefully.  
 Weiyao dropped a rubber ball from the heights marked (a), (b) and (c) which were 20 cm apart from the adjacent point. The clear tube had markings on it to allow Weiyao to take her readings.

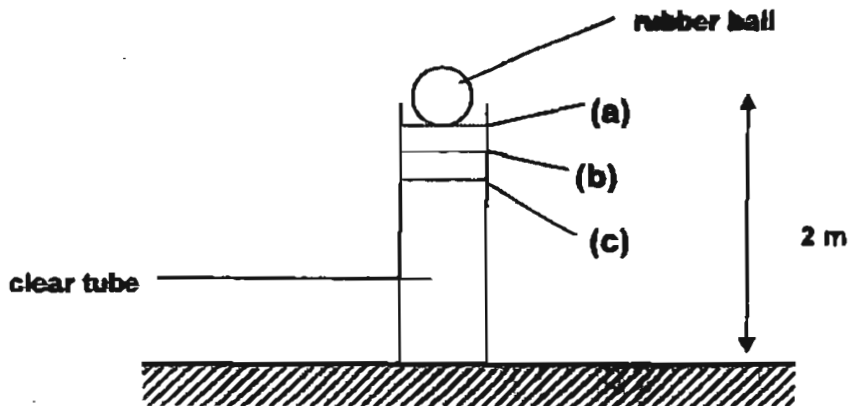

The table below shows the results that she had recorded.

Starting position	Height reached after each bounce (m)		
	1 <sup>st</sup> bounce	2 <sup>nd</sup> bounce	3 <sup>rd</sup> bounce
(a)	1.8	1.3	1
(b)	1.7	1.1	0.8
(c)	1.4	0.9	0.5

- (a) Based on the results, what is the relationship between the starting position and the height of the bounce? (1 mark)

---



---

- (b) Complete the following energy conversion of the experiment above by filling in the relevant information. (2 marks)

<p><b>Potential energy due to</b></p> <hr/> <hr/> <hr/>	<p>converted into</p>	<p><b>Kinetic energy as</b></p> <hr/> <hr/> <hr/>
---	-----------------------	---

45. The diagram below shows a mallet pivoted at one end. It was allowed to swing freely and hit a ball upon release from positions A and B.

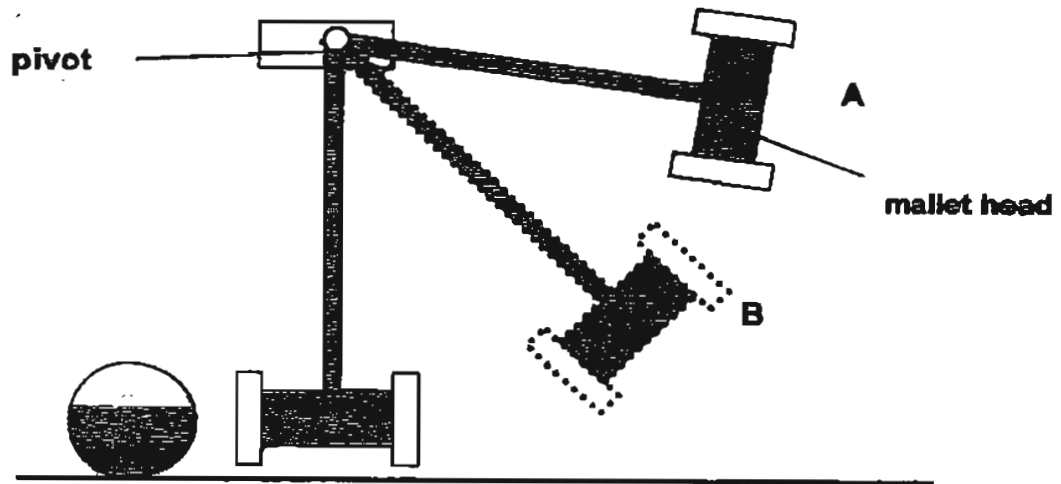

- (a) Compare the speeds of the ball when the mallet head is raised to position A and position B upon release. (1 mark)

---

---

- (b) Explain your answer in (a). (1 mark)

---

---

- (c) What observation(s) could be made of the ball when a heavier mallet head is released from position A? (1 mark)

---

---

46. A shooting range owner, Mr Watahi, wanted to study how powerful three types of guns, A, B and C were in order to select them for his new attraction at Sentosa. He fired paint pellets from the guns allowing them to hit a target. (A paint pellet is a ball of paint enclosed in a ball of plastic. Ejected from the air gun, these pellets will burst on impact to leave a splat of paint on the target.) The diagram below shows how the experiment is set up.

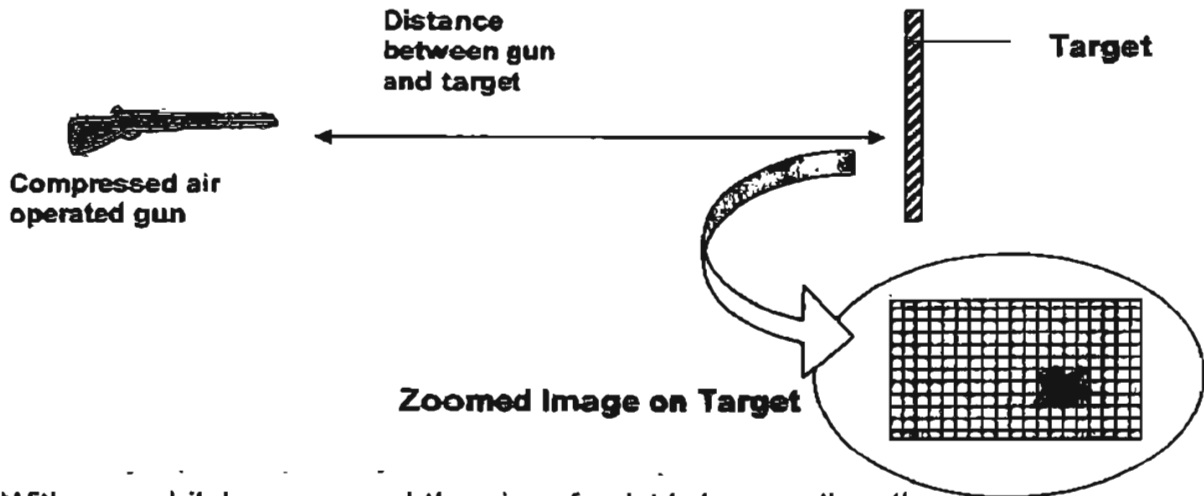

With every hit, he measured the size of splat by counting the number of squares it occupied on the grid. Then, he recorded his results in the table below.

Gun	Average area of paint splat (no. of squares)
A	50
B	45.5
C	65

For each statement below, put a tick (✓) in the correct column based on the information given above. (3 marks)

Statements	True	False	Not Possible to Tell
(a) The distance between the gun and the target must be different for each trial to make this experiment a fair test.			
(b) The paint pellet possesses more kinetic energy when it leaves a larger gun barrel.			
(c) Gun C is the most powerful.			

\*\*\*\*\* END OF PAPER \*\*\*\*\*

CAT

**NANYANG PRIMARY SCHOOL  
FIRST CONTINUAL ASSESSMENT 2005  
PRIMARY 6  
SCIENCE**

- 1) 3            28) 1
- 2) 2            29) 1
- 3) 3            30) 4
- 4) 3            31) a) Backbone
- 5) 4                      b) All have feathers/beak
- 6) 2            32) a) It is to exchange gases with the surroundings.
- 7) 3                      b) Underside of leaf in contact with water, so exchanging of gases is not easy; top surface of the leaf is exposed to air which allows easier exchange of gases to take place.
- 8) 3
- 9) 4
- 10) 4            33) a) Both have wings
- 11) 4                      b) B has patterns on its wings but A does not.
- 12) 1            34) a) without wing-like structure
- 13) 4                      with wing-like structure
- 14) 2                      b) The wing surface area enables the angsana fruit to be carried further away by wind.
- 15) 1            35) R
- 16) 1                      J
- 17) 1                      P
- 18) 4                      S
- 19) 3            36) a) X : carbon dioxide
- 20) 1                      Y : glucose
- 21) 3                      Z : oxygen
- 22) 4                      b) After some time, the excess glucose produced by the plant turned into starch.
- 23) 4            37) a) It provides the seedling with food.
- 24) 3                      b) It absorbs water and mineral salts for the seedling.
- 25) 4                      c) It needs water, warmth and oxygen.
- 26) 4
- 27) 2            38) A It supports the cell
- B It allows certain substances to pass through

- 38) C It controls the activities in the cell.  
 D It contains chlorophyll from the plant.
- 39) photosynthesis  
 heat light  
 electrical
- 40) a) He gets it from his food.  
 b) There is maximum potential energy at the top of the slope. At the bottom there is 0 potential energy.
- 41) a) electrical energy heat energy kinetic energy  
 b) Nichrome  
 c) Nichrome heats up to a high temperature within 10 minutes. Nichrome takes the shortest time to heat up to a high temperature.
- 42) a) To find out the effect of different volume of sound on the kinetic energy of the styrofoam beads.  
 b) 5th. 10th 15th 20th  
 A B C D
- 43) a) C, 0 lux could be detected.  
 b) The amount of Lux will decrease.
- 44) a) The lower the starting position, the lower the bounces will be.  
 b) Height of the ball The rubber ball came down from the ground
- 45) a) When the mallet head raised to A, the ball moved faster compared to B.  
 b) At A, the mallet head had more potential energy than B, hence there were more kinetic energy when the mallet head came down.  
 c) The ball moved even further.
- 46) a) False  
 b) Not possible to tell  
 c) True