

**Anglo-Chinese School  
(Junior)**



**NON-WEIGHTED BITE-SIZED ASSESSMENT ONE (2024)  
PRIMARY 6**

**SCIENCE**

Monday

26 February 2024

50 min

**INSTRUCTIONS TO PUPILS**

**DO NOT TURN OVER THE PAGES UNTIL YOU ARE TOLD TO DO SO**

Follow all instructions carefully.

There are 18 questions in this booklet.

Answer ALL questions.

Name: \_\_\_\_\_ (      )

Class: 6. (      )

Parent's Signature: \_\_\_\_\_

Booklet	Possible Marks	Marks Obtained
A	20	
B	30	
<b>TOTAL</b>	<b>50</b>	

This question paper consists of 18 printed pages. (Inclusive of cover page)

For each question from 1 to 10, four options are given. One of them is the correct answer. Make your choice (1, 2, 3 or 4). Shade your answer on the Optical Answer Sheet.

(20 marks)

1. Study the diagram of a toy car.

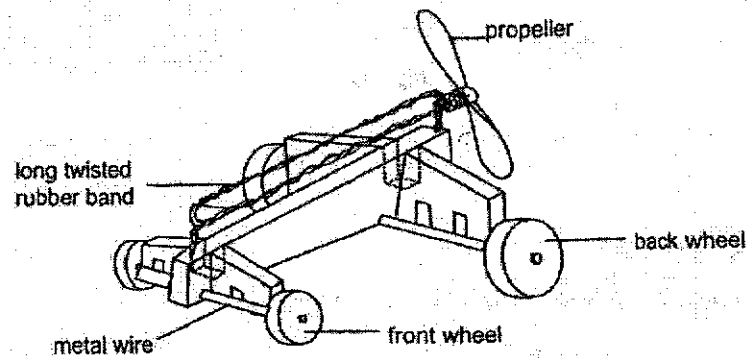

Which part of the toy car possesses the source of energy which enables it to move when it is released?

- (1) Wheels
- (2) Propeller
- (3) Metal wire
- (4) Twisted rubber band

2. The diagram shows how sea waves can be used to generate electricity. The waves push the water into the barrier which pushes the air in the chamber, causing the turbine to turn.

The turbine is connected to a generator which produces electricity.

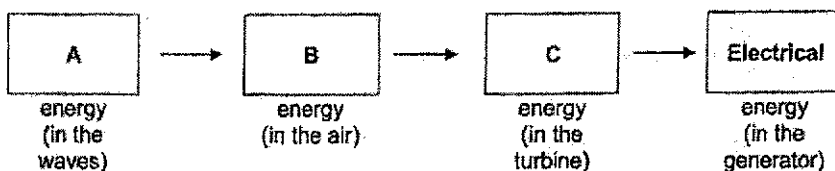
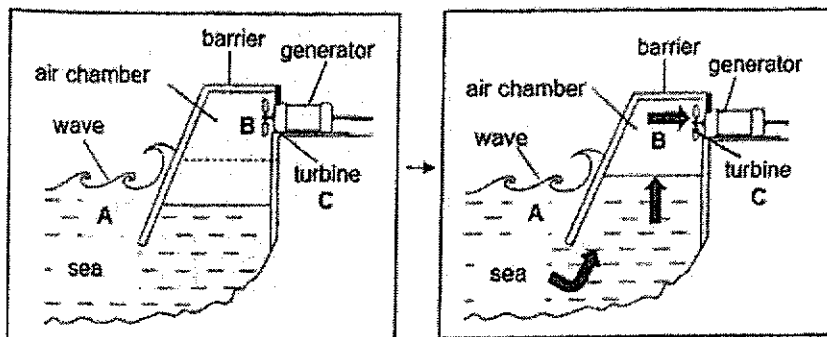

Which of the following correctly shows the main forms of energy at A, B and C?

	A	B	C
(1)	Kinetic	Heat	Kinetic
(2)	Potential	Potential	Heat
(3)	Kinetic	Kinetic	Kinetic
(4)	Potential	Kinetic	Sound

3. The graph below shows the extension of two springs, P and Q, when loads were hung on them.

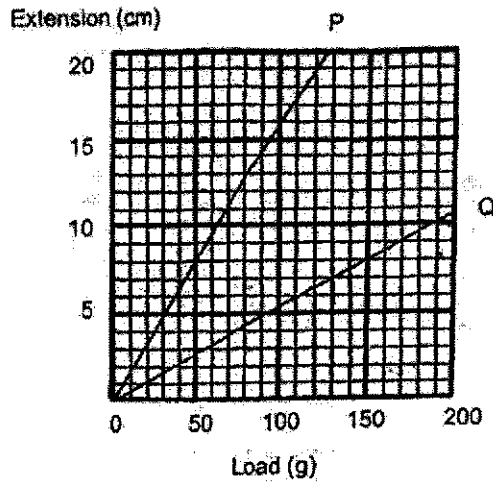

Based on the graph, which of the following statements is correct?

- (1) The extension of both springs is the same for the same load hung.
- (2) The length of spring P increased by 8cm when a load of 50g is hung.
- (3) The original length of spring P is longer than the original length of spring Q.
- (4) Spring Q has more elastic potential energy than spring P when the same load is hung.

4. Elliott sets up three similar electrical circuits to find out which brand of battery stores the most energy. Each circuit consists of a bulb, a switch and a battery as shown.

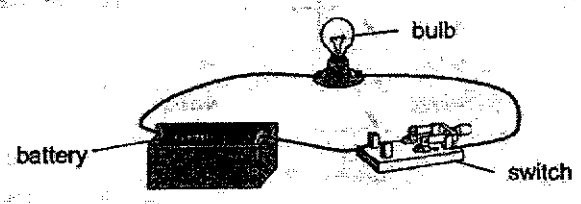

Which of the following correctly shows the variables to be changed and kept constant to conduct a fair experiment?

	Variable to be changed	Variable to be kept constant
(1)	Brand of batteries	Duration the bulb is lit
(2)	Brand of batteries	Type of bulb
(3)	Duration the bulb is lit	Brand of batteries
(4)	Duration the bulb is lit	Type of bulb

5

5. Farhan rolled a ball down a slope as shown. The graph shows the amount of different types of energy of the ball at point X.

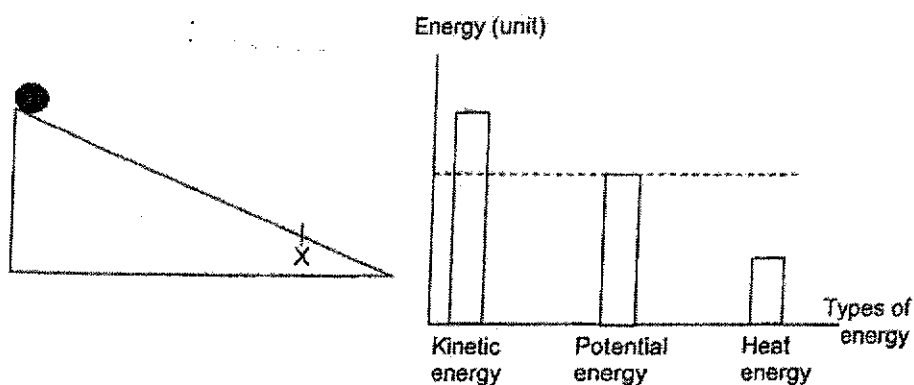

- He poured some sand on the slope and released the ball.  
Which of the following shows the amount of different types of energy at point X?

	Kinetic Energy	Potential Energy	Heat Energy
(1)	Increase	Remains the same	Decrease
(2)	Remains the same	Decrease	Decrease
(3)	Decrease	Increase	Increase
(4)	Decrease	Remains the same	Increase

6. A ball is moving in the direction as shown.

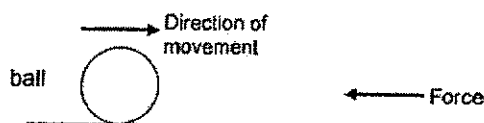

Which of the following may take place when a force is applied in the opposite direction of the moving ball?

- A The ball will stop moving.  
 B The mass of the ball will change.  
 C The ball will move in another direction.  
 D The ball will move slower in the same direction.
- (1) A only  
 (2) B and C only  
 (3) B and D only  
 (4) A, C and D only

6

7. Lele wanted to find out which liquid is the best lubricant for reducing friction between two surfaces. He set up the experiment as shown.

He coated the surface of the ramp with liquid A and released the plastic box from point P. He measured the time taken for the plastic box to reach Point Q.

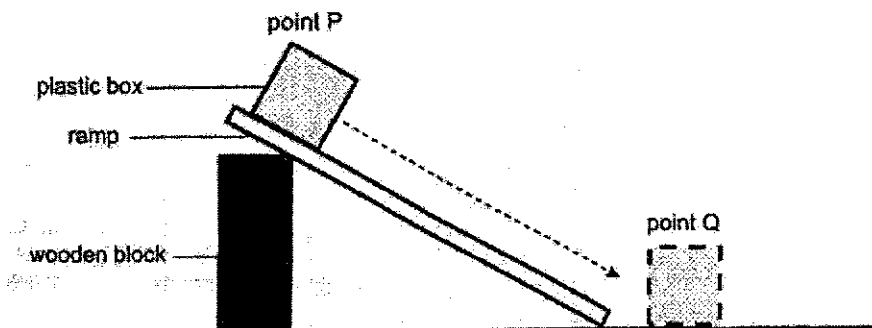

The experiment was then carried out with liquids B, C and D.

The table shows the time taken for the plastic box to reach point Q.

Type of liquid	Time taken for the box to reach point Q (seconds)
A	1
B	4
C	3
D	2

Which lubricant reduces the most amount of friction?

- (1) A
- (2) B
- (3) C
- (4) D

8. Ming set up an experiment as shown. He released the wooden block at point X. It moved down the ramp until point Z, before moving back a little and finally stopping at point Y. The block did not touch object P.

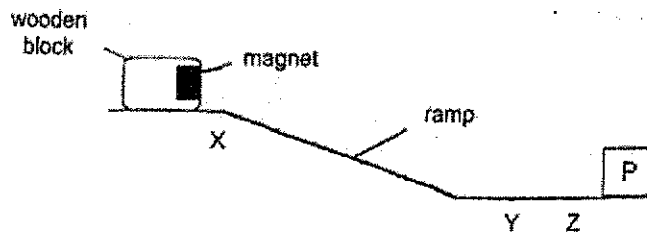

Which of the following statements are true?

- A The block did not touch object P due to magnetic force.
- B There is only magnetic force acting on the block at point Z.
- C There was gravitational force acting on the block at point X.

- (1) A only
- (2) B only
- (3) A and C only
- (4) B and C only

9. A ball is rolling down a slope as shown.

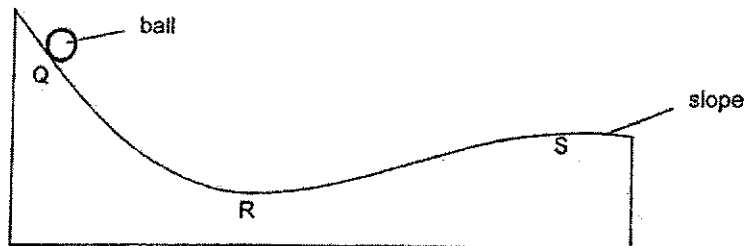

Which of the following correctly shows how gravitational force and gravitational potential energy is affected as the ball rolls from R to S?

	Gravitational Force	Gravitational Potential Energy
(1)	Increase	Remains the same
(2)	Decrease	Remains the same
(3)	Remains the same	Increase
(4)	Remains the same	Decrease

10. Arielle placed object X on the table in front of a spring as shown.

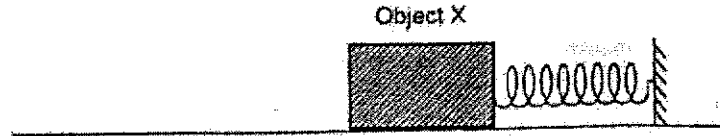

She then placed a magnet near Object X and it moved as shown.

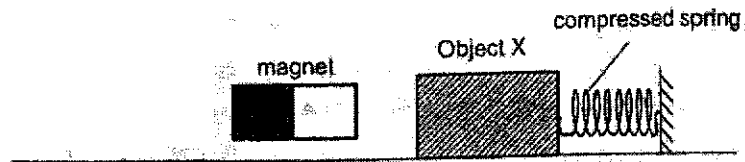

Which of the following correctly shows the direction of force acting on Object X?

	Magnetic Force	Frictional Force	Elastic Spring Force
(1)	→	←	←
(2)	→	→	←
(3)	←	←	←
(4)	←	→	→



For questions 11 to 18, write your answers in this booklet.  
The number of marks available is shown in brackets [ ] at the end of each question or part question.

(30 marks)

11. The diagram shows the positions of a basketball as it drops from position X till it lands on the wet sand and makes a depression,  $d$ .

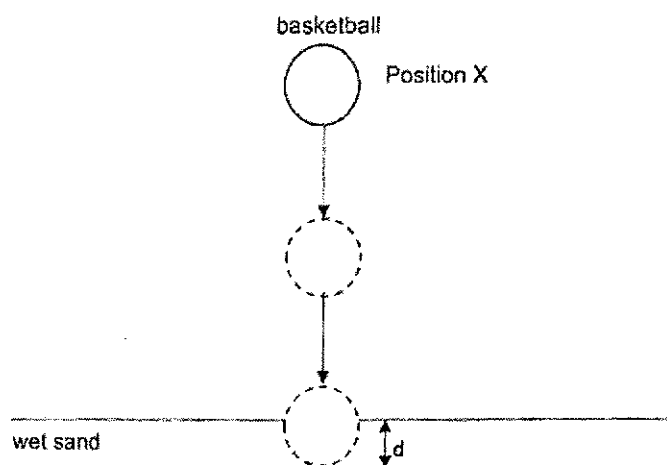

- (a) State the main form of energy of the basketball at position X. [1]

\_\_\_\_\_

- (b) Suggest one way to increase the depth of depression,  $d$ , of the basketball in the wet sand. [1]

\_\_\_\_\_

- (c) Why was wet sand used instead of dry sand to measure the depression,  $d$ , made by the basketball? [1]

\_\_\_\_\_

\_\_\_\_\_

(Go on to the next page)

SCORE	3
-------	---

12. The diagram shows a steam train. The water heated in the boiler produces steam which goes through the cylinder, causing the piston to move. As the piston moves, the wheels attached to the rod also moves.

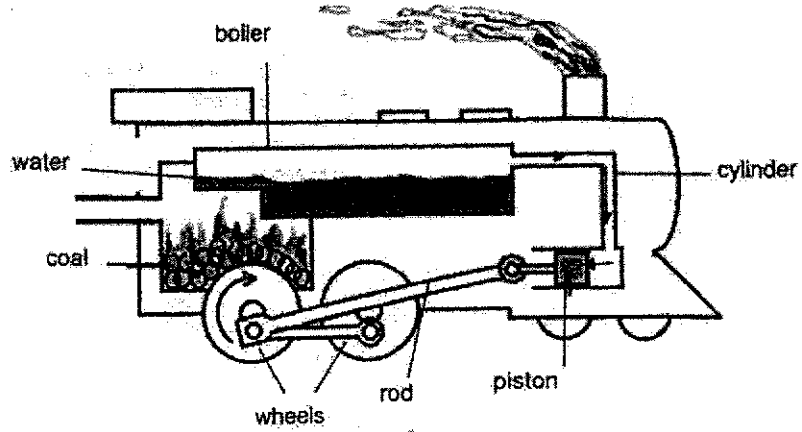

- (a) What is the source of energy for the above train? [1]

---

- (b) Fill in the boxes to show the main energy conversion of the moving steam train. [2]

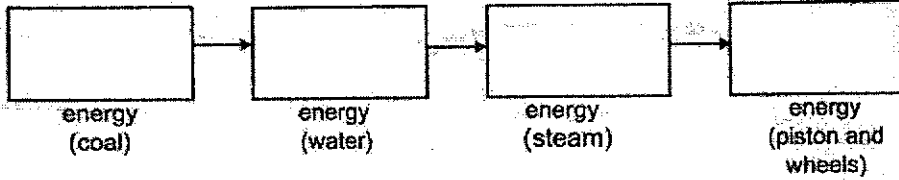

- (c) A Maglev train uses magnets on the train and its tracks to keep it moving.

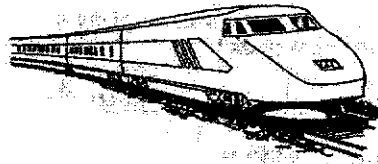

- State an advantage of using the Maglev train instead of a steam train. [1]

---



---

(Go on to the next page)

SCORE	4
-------	---

13. Divya conducted an experiment using the set-up as shown.

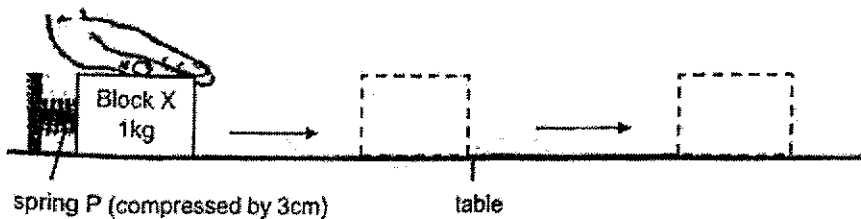

She pulled block X back until spring P was compressed by 3cm.

When she released block X, it moved a distance before coming to a stop.

- (a) Where does Divya's energy come from? [1]

---

- (b) Explain why block X stopped moving after some time. [1]

---



---

- (c) Divya repeated her experiment with block Y of mass 4kg and compressed the spring by 3cm.

Would block Y move a greater or shorter distance than block X?  
Explain your answer in terms of energy.

[1]

---



---

(Go on to the next page)

SCORE	/
	3

-12

14. Farhan is playing with an archery toy. To release the arrow, he has to pull back the arrow along with the rubber band. He wants to find out how the distance,  $d$ , between the bow and rubber band would affect the distance travelled by the arrow.

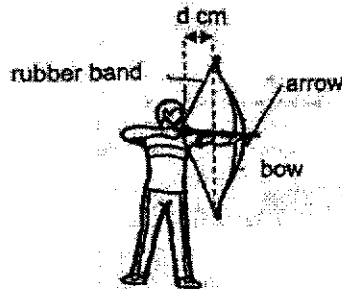

He recorded his results in the table.

Distance, $d$ , between the bow and the rubber band (cm)	Distance travelled by the arrow (cm)
10	30
15	40
20	50
25	60
30	70

- (a) State what energy is. [1]
- 
- (b) Name the form of energy present in the stretched rubber band. [1]
- 
- (c) Based on the results, state the relationship between distance,  $d$ , and the distance travelled by the arrow. [1]
- 
- (d) Suggest a change he can make to the rubber band to increase the distance travelled by the arrow. [1]
- 

(Go on to the next page)

SCORE	4
-------	---

15. Dave puts one mass on the hook. He uses a spring balance to pull the hook and measures the amount of force needed to start moving the hook.

- (a) Draw an arrow ( $\rightarrow$ ) in the picture below to show the direction of his pull force. [1]

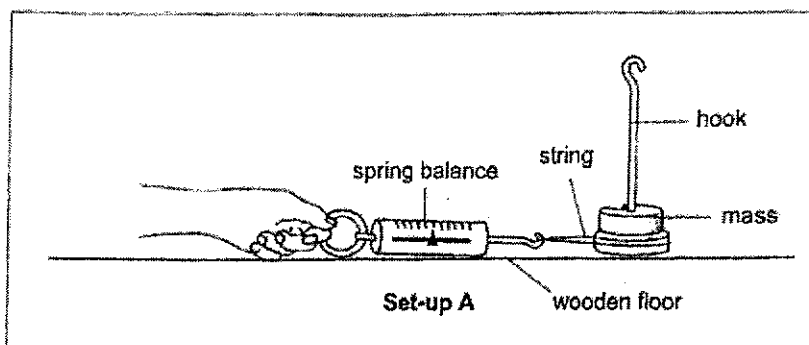

Dave wants to conduct an experiment and adds different number of identical masses to the hook and measures the amount of force needed to move the hook each time.

Dave records the results in the table.

Number of masses	Amount of force needed to move the hook (units)
1	3
2	4
3	6
4	7

- (b) What is the aim of Dave's experiment? [1]

---



---

- (c) How will the amount of force needed to move the hook change if Dave conducted his experiment on a carpeted floor instead of the wooden floor? [1]

---

- (d) Dave now wants to find out how the type of surface affects the amount of force needed to move the hook. What variables should Dave change and keep constant in set-up A to carry out this new experiment? Tick ( $\checkmark$ ) the correct boxes. [1]

Variables	Change	Keep Constant
String		
Type of surface		
Spring balance		
Number of masses		

(Go on to the next page)

SCORE	4
-------	---

16. A pen manufacturer wants to develop a pen with an erasable ink that can be erased in the shortest time and will not reappear after being erased.  
 He discovered that the ink can become colourless when heat is applied.

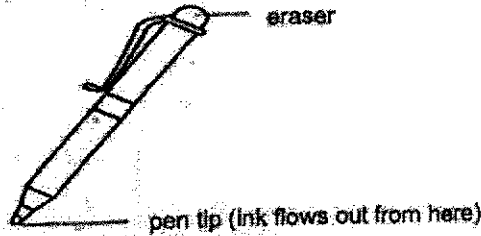

The pen manufacturer tested the pen with four different inks, R, S, T and U.

The time taken to erase the ink with a machine was recorded. The same amount of force was used throughout the erasing process to ensure that it is a fair test. The observations from the tests were recorded in the table.

Observations		
ink	Time taken to erase the ink (s)	Does the ink reappear
R	0.5	Yes
S	0.4	Yes
T	0.3	No
U	0.9	No

- (a) Which ink, R, S, T and U is the most suitable ink to be used in the pen?  
 Explain your answer based on the information in the table.

[1]

---

- (b) How can the eraser on the pen cause the ink to be colourless?  
 Explain your answer in terms of forces.

[1]

---



---

(Go on to the next page)

SCORE	2
-------	---

The pen manufacturer also developed other types of pens which are used commonly by students.

Students notice that writing with a pen of a smaller mass requires less force to make a mark on paper, compared to a pen of a greater mass.

- (c) State the force(s) applied when using a pen to write. [1]

---

- (d) Explain why less force is needed to write on a paper using a pen with a smaller mass, as compared to a pen with a greater mass. [1]

---

---

(Go on to the next page)

SCORE	2
-------	---

17. Sam carried out an experiment on three similar pipes, A, B and C, of different lengths. He blew a dart through the pipes. He measured the distance moved by the dart after each try.

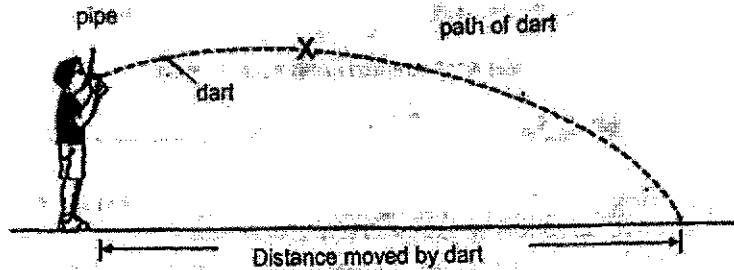

His results are shown in the table.

	Distance moved by the dart (cm)		
	Pipe A (length = 10cm)	Pipe B (length = 15cm)	Pipe C (length = 20cm)
1 <sup>st</sup> try	100	208	318
2 <sup>nd</sup> try	118	205	323
3 <sup>rd</sup> try	114	210	326

- (a) State what a force is. [1]
- 
- (b) For pipe A, suggest a reason why the distance moved by the dart was different for each try. [1]
- 
- (c) Name the force that caused the dart to move downwards at X. [1]
- 
- (d) Sam used the same dart throughout the experiment. Give a reason how using the same dart helps to make the experiment a fair test. [1]
- 

(Go on to the next page)



18. Chris sat in a sled he designed and used it to slide down a grass slope from point X. For safety reasons, Chris must remain seated in the sled.

Chris wore gloves to protect his hands from the abrasion of the grass and could only use his glove-covered hands to control the speed of his sled by either pressing down on the grass or pushing against the grass to propel himself forward.

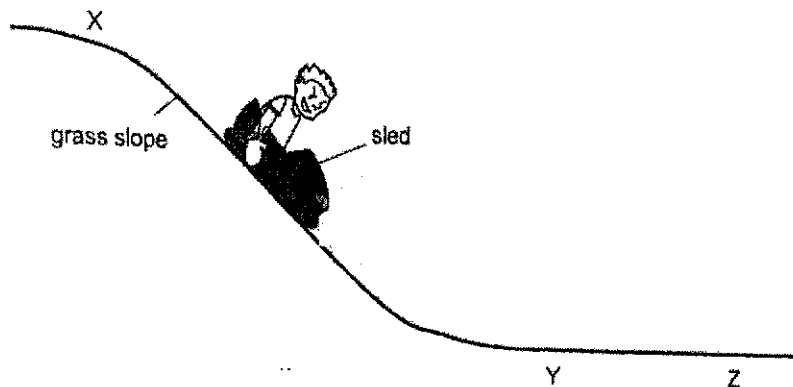

After controlling the speed of the sled with his glove-covered hands, the sled came to a stop at point Z.

- (a) Describe what Chris should do if he wanted to safely stop his sled at point Y. [1]

---

---

- (b) Chris would like to slide down the grass slope faster. Apart from controlling the speed of his sled with his glove-covered hands, suggest two things he can do. [2]

---

---

(Go on to the next page)

SCORE	3
-------	---

Chris designed a backpack that could open a parachute as shown.

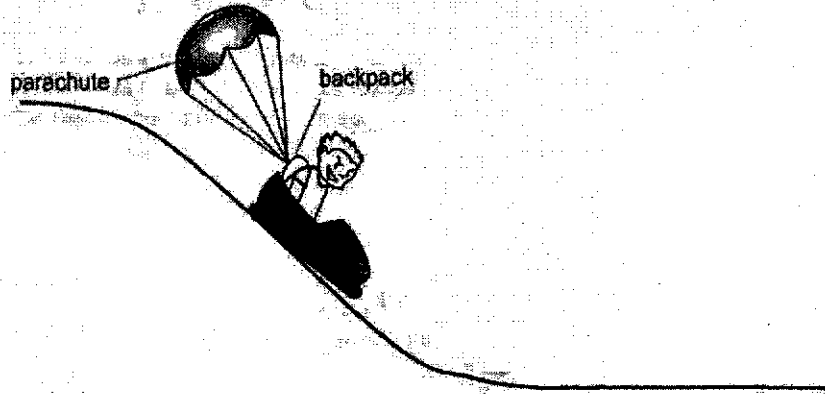

He wanted to use a fabric to make a parachute that could stop the sled in the shortest time possible.

He was deciding between using Fabric A and Fabric B, as shown. Both use the same type of strong fibres.

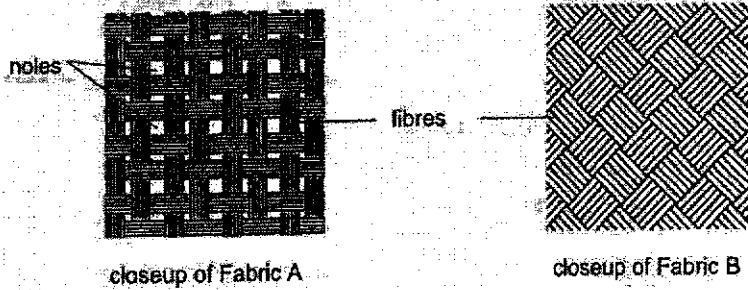

(c) Should Chris use Fabric A or Fabric B? Explain your answer.

[1]

---

---

End of Paper

SCORE	
-------	--

**SCHOOL : ACS (J) PRIMARY SCHOOL**

**LEVEL : PRIMARY 6**

**SUBJECT : SCIENCE**

**TERM : 2024 WA1**

Q1	Q2	Q3	Q4	Q5	Q6	Q7	Q8	Q9	Q10
4	3	2	2	4	4	1	3	3	1

Q11)	<p>a) Gravitational potential energy</p> <p>b) Increase the height the basketball was dropped at.</p> <p>c) It is easier to make a depression.</p>
Q12)	<p>a) coal.</p> <p>b) Chemical Potential energy → Heat energy → kinetic energy → kinetic energy</p> <p>c) The Maglev train does not pollute the air.</p>
Q13)	<p>a) It comes from the food she eats.</p> <p>b) Some of block X's kinetic energy was converted to heat and sound energy, and eventually, all the kinetic energy would have been converted to heat and sound energy and hence block X stopped moving at the same time.</p> <p>c) As block Y was now 4kg instead of block X, which was 1kg the amount of energy needed to make it travel the same distance would be more and as spring P was compressed the same amount (3cm), the amount of energy would be the same, hence block Y would move a shorter distance than block X.</p>
Q14)	<p>a) energy is a force inside an object that allows it to move.</p> <p>b) Elastic potential energy</p> <p>c) As distance d, between the bow and the rubber band increase, the distance travelled by the arrow also increases.</p> <p>d) Use a stiffer rubber band.</p>

Q15)	<p>a)</p>  <p>b) To find out how the number of masses affect the amount of force needed to move the hook.</p> <p>c) The amount of force needed to move the hook will increase.</p> <p>d) spring balance</p> <p>Number of masses</p>
Q16)	<p>a) Ink T. Inks R and S cannot be used as they will reappear even after being erased. Though both Inks T and U will not reappear after being erased, when using ink T, the time taken to erase the ink is shorter.</p> <p>b) When the eraser is being used to erase the ink, the heat generated from the eraser will make the ink be colour less.</p> <p>c) Push and pull</p> <p>d) There is less friction between the pen tip and the paper.</p>
Q17)	<p>a) A force a pull or pushes</p> <p>b) Sam used a different angle when he was holding the pipe</p> <p>c) gravitational force</p> <p>d) It Sam used different darts, thought out then would be changes in the quality of the darts, and some darts may, fly further than others. By using the some darts, some ensure that the only changed variable of the length of pipes.</p>
Q18)	<p>a) He should exert less force when pushing down from point X if he want to safely stop his sled at point Y.</p> <p>b) He can increase the mass at the sled. He can get a friend to push the sled</p> <p>c) Fabric B. It has no gup's and thus blocking more air.</p>