

**Henry Park Primary School  
Primary Six Science  
2024 Term Review 2**

Name: \_\_\_\_\_ ( ) Class: 6 \_\_ Parent Signature: \_\_\_\_\_

Booklet A (56 marks)      Duration:      1 h 45 min      Marks:      \_\_\_\_\_ / 56

For each question from 1 to 28, four options are given. One of them is the correct answer.

Make your choice (1, 2, 3 or 4). Shade the correct oval (1, 2, 3 or 4) on the **Optical Answer Sheet**.

1. The table shows how some living things are classified into two groups, A and B.

| Group A                        | Group B                       |
|--------------------------------|-------------------------------|
| rose plant<br>bird's nest fern | bread mould<br>bracket fungus |

Which one of the following correctly describes groups A and B?

|     | Group A                 | Group B                   |
|-----|-------------------------|---------------------------|
| (1) | flowering plants        | non-flowering plants      |
| (2) | do not have chlorophyll | have chlorophyll          |
| (3) | reproduce from seeds    | reproduce from spores     |
| (4) | able to make own food   | not able to make own food |

2. The diagram of cell X was shown to three students, Anna, Ben and Carlene.

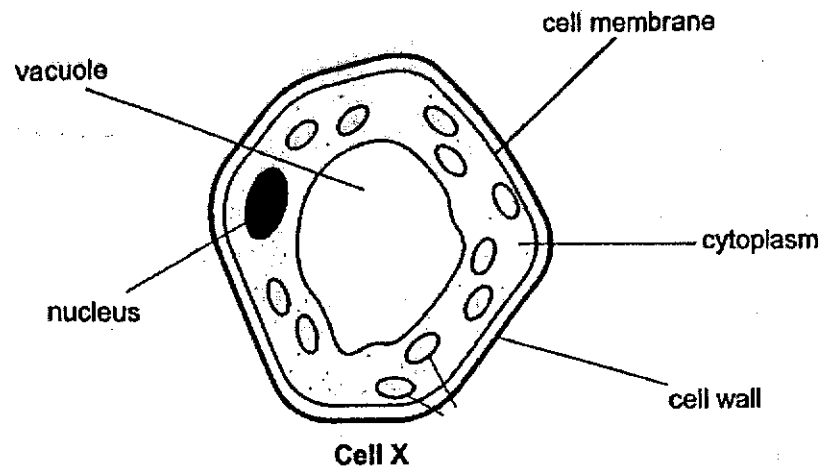

After looking at the diagram of the cell, they made the following statements:

- Anna : It is an animal cell as it has no chloroplasts.  
 Ben : The cytoplasm is a substance that contains many cell parts.  
 Carlene : Cell X is likely to be an animal cell as it does not have a rectangular shape.

Whose statement(s) is / are correct?

- (1) Anna only
- (2) Ben only
- (3) Ben and Carlene only
- (4) Anna and Carlene only

3. The diagram shows part of a flower.

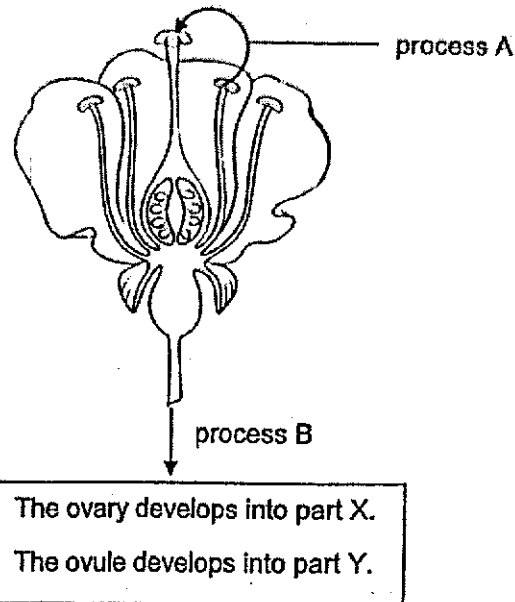

Which of the following could processes A and B and parts X and Y be?

|     | Process       |                | Part  |       |
|-----|---------------|----------------|-------|-------|
|     | A             | B              | X     | Y     |
| (1) | fertilization | germination    | fruit | seed  |
| (2) | fertilization | seed dispersal | seed  | fruit |
| (3) | pollination   | seed dispersal | seed  | fruit |
| (4) | pollination   | fertilization  | fruit | seed  |

4. Which of the following statements about the plant transport system are correct?

- J The food-carrying tubes can only transport food in the upwards direction.
- K The water-carrying tubes can only transport water and minerals in the upwards direction.
- L The food-carrying tubes can transport food in either upwards or downwards directions.
- M The water-carrying tubes can transport water and minerals in either upwards or downwards directions.

- (1) J and K
- (2) K and L
- (3) J and M
- (4) L and M

5. The bar graph shows the amount of undigested food as it enters different organs (parts V, W, X, Y and Z) in the digestive system after a meal.

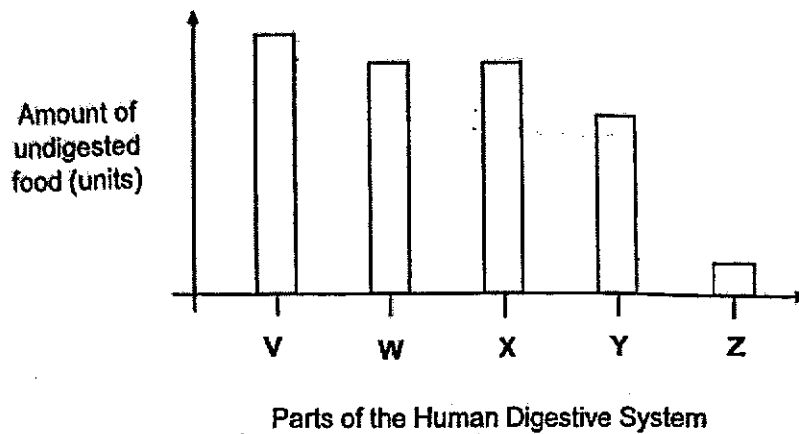

Based on the information given, which of the following statement(s) is / are correct?

- A Digestion starts in part X.
- B Digested food is absorbed in part Z.
- C Digestion does not take place in part W.

- (1) B only
- (2) C only
- (3) B and C only
- (4) A and C only

6. Sally conducted an experiment on photosynthesis. She placed 3 similar pots of plants in a dark room and watered them daily. After 3 days, the pots of plants were placed in set-ups A, B and C, containing substances X, Y and Z. All the set-ups were placed under the sun.

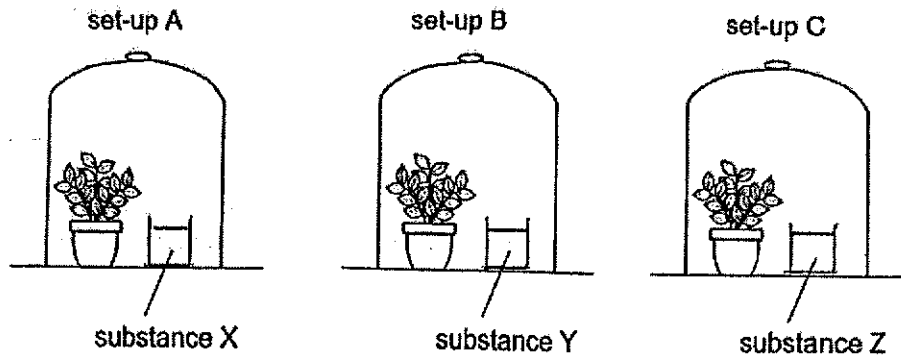

After 6 hours, Sally removed a leaf from each of the set-ups and conducted a starch test on them.

The observations were recorded in the table below.

| Leaf from | Results of starch test          |
|-----------|---------------------------------|
| set-up A  | iodine turned dark blue         |
| set-up B  | iodine turned dark blue         |
| set-up C  | iodine remained yellowish brown |

Which of the following is most likely to be substances X, Y and Z?

|     | substance X             | substance Y             | substance Z             |
|-----|-------------------------|-------------------------|-------------------------|
| (1) | water                   | produces carbon dioxide | absorbs carbon dioxide  |
| (2) | absorbs water vapour    | absorbs oxygen          | produces carbon dioxide |
| (3) | absorbs carbon dioxide  | water                   | absorbs oxygen          |
| (4) | produces carbon dioxide | absorbs water vapour    | water                   |

7. Jack set up the experiment as shown below.

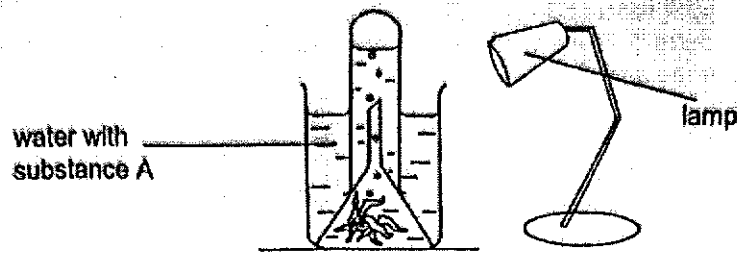

He adds substance A which removes carbon dioxide in the water. Any carbon dioxide given out by the plant is absorbed by substance A immediately. He switches on the lamp and measures the amount of oxygen in the water.

What will Jack observe after one day?

- A: The water plant will die.
- B: Number of bubbles in the water will not change.
- C: Number of bubbles in the water will increase.
- D: Number of bubbles in the water will decrease.

- (1) B only
- (2) C only
- (3) D only
- (4) A and D only

8. Which of the following human body systems work together when a student is eating her snack?

- A Skeletal
- B Digestive
- C Muscular
- D Reproductive

- (1) A and B only
- (2) A, B and C only
- (3) B, C and D only
- (4) A, B, C and D

9. The diagram below represents the flow of substances among the various organ systems in the human body.

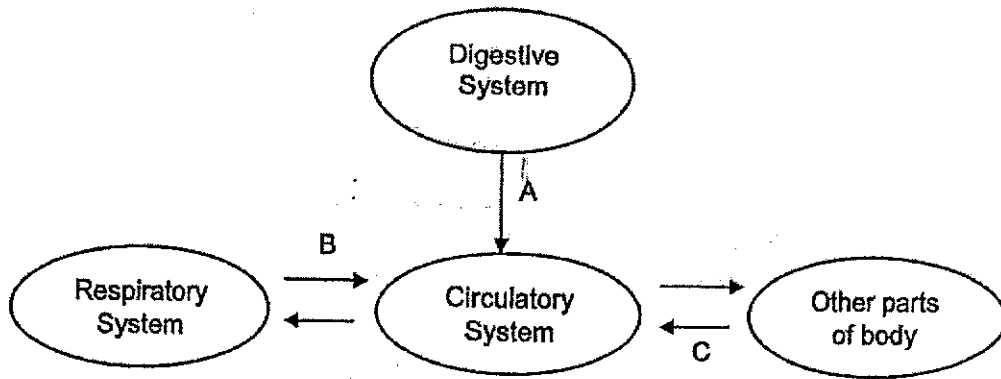

Which one of the following options correctly represents the arrows in the diagram?

|     | A               | B                            | C                            |
|-----|-----------------|------------------------------|------------------------------|
| (1) | digested food   | blood rich in oxygen         | blood rich in carbon dioxide |
| (2) | digested food   | blood rich in carbon dioxide | blood rich in oxygen         |
| (3) | undigested food | blood rich in oxygen         | blood rich in carbon dioxide |
| (4) | undigested food | blood rich in carbon dioxide | blood rich in oxygen         |

10. A group of scientists discovered that certain parts of a river were polluted with toxic chemicals as shown in the diagram below.

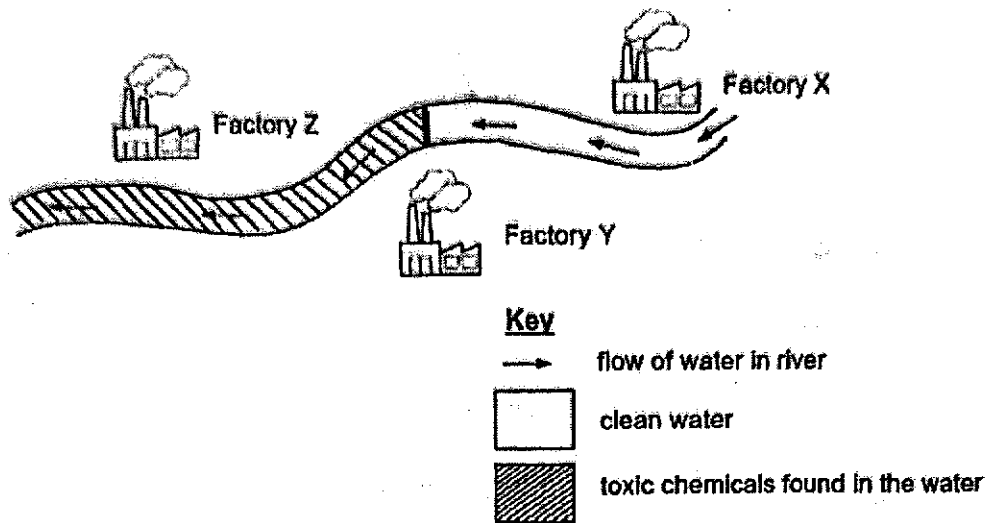

Which one of the following options correctly shows which factory / factories was / were responsible for polluting the river?

|     | Factory X            | Factory Y | Factory Z            |
|-----|----------------------|-----------|----------------------|
| (1) | Not possible to tell | Yes       | Not possible to tell |
| (2) | No                   | Yes       | Yes                  |
| (3) | No                   | No        | Not possible to tell |
| (4) | Yes                  | No        | No                   |



11. Mr. Razid conducted an experiment using the flowers of a particular plant in his garden. He wanted to find out if a flower would still develop into a fruit when only a certain part of the flower was removed.

| Flower | Part removed    |
|--------|-----------------|
| A      | the stigma      |
| B      | all the anthers |
| C      | all the petals  |

He dusted pollen grains of the same type of flowers over flowers A, B and C. Then he observed them over two weeks.

Which of the flower(s) is / are more likely to have developed into fruits at the end of the two weeks?

- (1) C only
  - (2) A and B only
  - (3) B and C only
  - (4) A, B and C
12. The following statements describe what happens during sexual reproduction in plants.
- A: Ovule develops into a seed.
  - B: The anther releases pollen grains.
  - C: Pollen grains are transferred to the stigma.
  - D: Male reproductive cells fuse with the female reproductive cells.
  - E: Pollen tube grows towards the ovary.

Which of the following shows the correct sequence of the process?

- (1) B → E → C → D → A
- (2) B → C → E → D → A
- (3) C → D → A → B → E
- (4) C → B → D → A → C

13. The diagram below shows the human reproductive system.

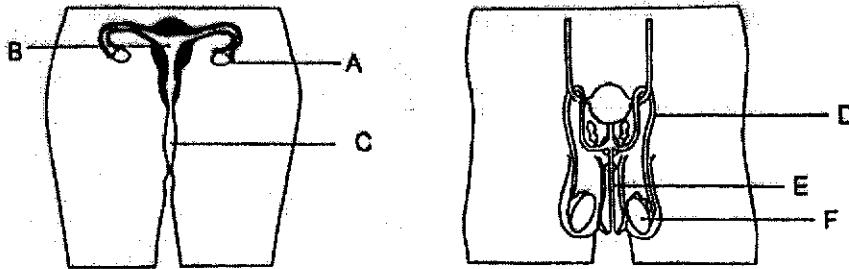

Which of the following is correct?

|     | where the female reproductive cell is produced | where the male reproductive cell is produced | where the fertilised egg is developed |
|-----|--|--|---------------------------------------|
| (1) | A  | F  | B                                     |
| (2) | B  | F  | A                                     |
| (3) | C  | E  | B                                     |
| (4) | A  | D  | C                                     |

14. Wei Ming set up three test tubes as shown in the diagram below. At the start of the experiment, solution X in each test tube is red. In the presence of carbon dioxide, the indicator changes from red to yellow.

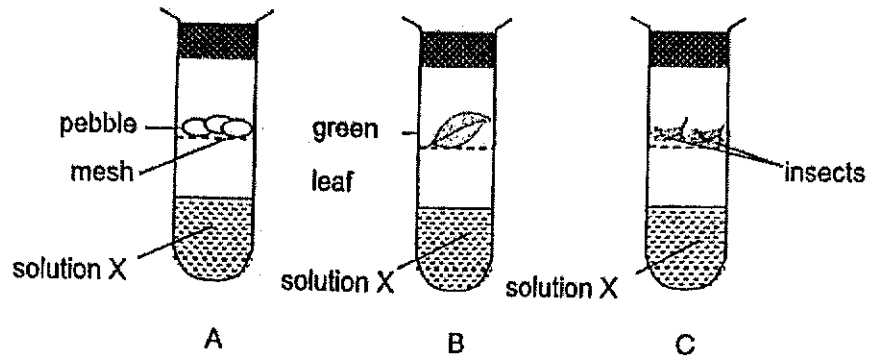

What will be the colour of the indicator in each test tube after a few hours?

|     | A   | B      | C      |
|-----|-----|--------|--------|
| (1) | red | red    | red    |
| (2) | red | red    | yellow |
| (3) | red | yellow | red    |
| (4) | red | yellow | yellow |

15. Jack wanted to study how the volume of a substance, X, affects its mass. He took a certain amount of substance X and measured its mass and volume.

Which of the following should Jack do to ensure the results of his experiment will be accurate?

- A Repeat the experiment using different substances.
  - B Keep the temperature of substance X the same during the experiment.
  - C Measure the mass and volume using different amounts of substance X.
- (1) C only  
 (2) A and B only  
 (3) B and C only  
 (4) A, B and C

16. The diagram below shows a white cloud forming above the kettle spout when water in the kettle boils.

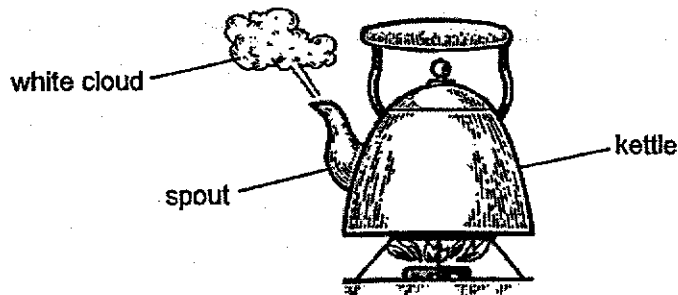

Which of the following activities show a similar process as the formation of the white cloud above the spout?

- A: Filling an empty cup with ice-water.
  - B: Drying our wet hair with a hair dryer.
  - C: Putting a hot bun into a styrofoam box.
  - D: Breathing out through our mouth onto spectacle lenses.
- (1) A and D only  
 (2) B and C only  
 (3) A, C and D  
 (4) A, B, C and D

17. Harry set up the experiment as shown below.

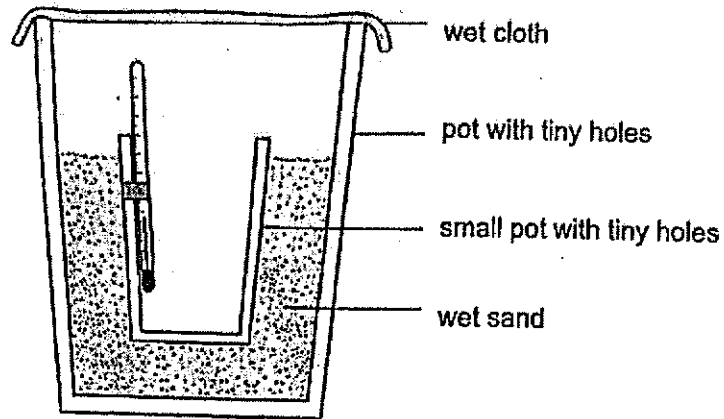

He placed the set-up in a dry place. He recorded the temperature of the air inside the small pot. His results are shown below.

| Time (minutes) | Temperature ( $^{\circ}\text{C}$ ) |
|----------------|------------------------------------|
| 0              | 30                                 |
| 10             | 28                                 |
| 20             | 27                                 |

The drop in the temperature of the air inside the small pot was mainly due to \_\_\_\_\_.

- (1) water evaporating from the wet sand
- (2) heat being conducted to the thermometer
- (3) water vapour condensing on the wet sand
- (4) wet sand acting as a poor conductor of heat

18. Sunita wanted to boil some potatoes. She noticed that when she put the potatoes into the boiling water, the boiling stopped almost immediately for a short while as shown below.

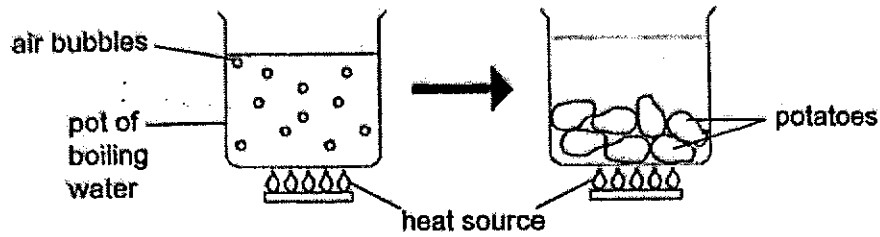

Why did the water stop boiling for a short while when the potatoes are put into it?

- (1) The potatoes lost heat to the water.
  - (2) The boiling water lost heat to the potatoes.
  - (3) The potatoes lost its coldness to the water.
  - (4) The boiling water had increased its volume.
19. The ring and the ball shown below were made of the same material.



At room temperature, the ball was unable to pass through the ring. After heating the ring for a while, the ball passed through the ring.

Which of the following explains this observation?

|     | The ring               | The ball               |
|-----|------------------------|------------------------|
| (1) | expanded               | contracted             |
| (2) | expanded               | remained the same size |
| (3) | remained the same size | contracted             |
| (4) | remained the same size | remained the same size |

20. When a ball was placed between a torch and a white screen, a shadow was seen on the screen as shown below.

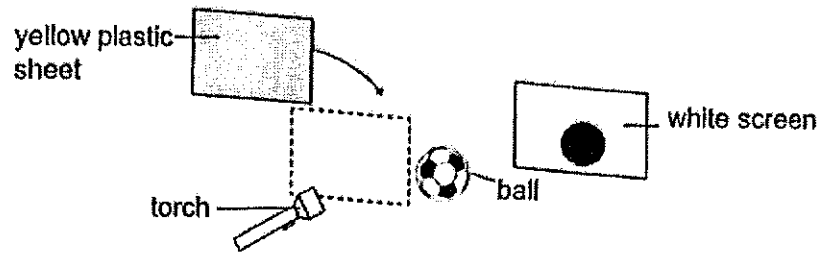

A yellow plastic sheet was then placed in front of the torch. The yellow plastic sheet allowed most light to pass through.

What would be observed on the same screen if the yellow plastic sheet was placed in front of the torch?

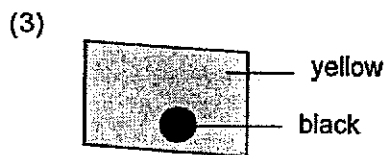
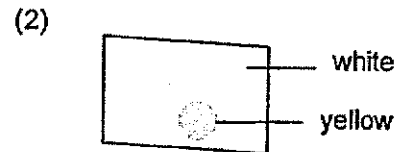
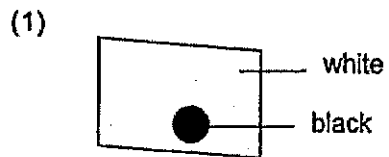

21. Ahmad set up an experiment as shown below. When he connected the metal clips to the edges of the container made of material Y, the bulb lit up.

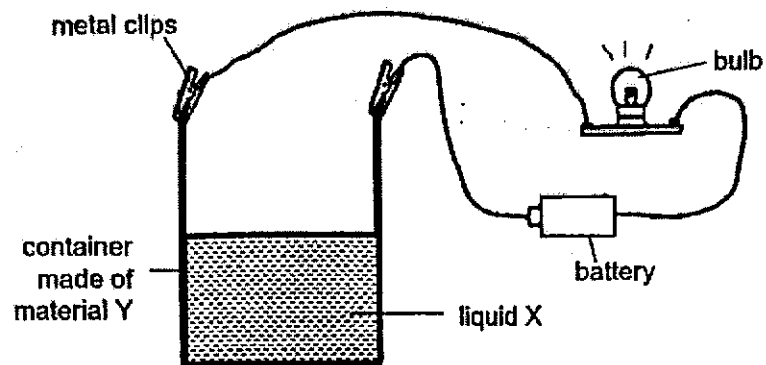

Which of the following statements can be concluded from Ahmad's observation?

- (1) Material Y is an insulator of electricity.
- (2) Material Y is a conductor of electricity.
- (3) Liquid X is an insulator of electricity.
- (4) Liquid X is a conductor of electricity.



22. Study the circuit below. Bulbs A, B and C are identical. At first, bulb A is unlit while bulbs B and C are lit with a brightness of 10 units.

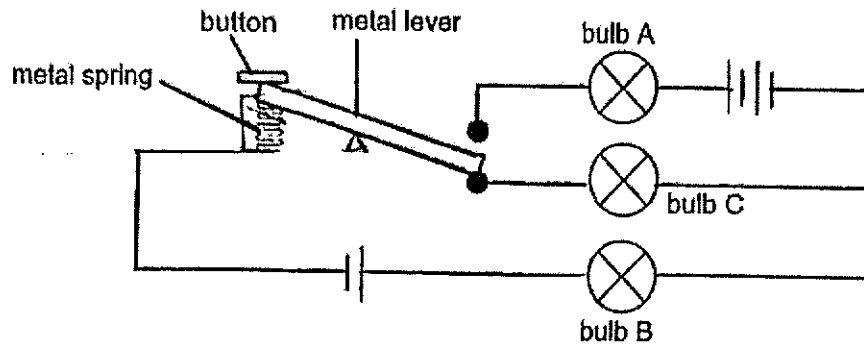

If the button is pressed and held down, what would happen to bulbs A and B?

|     | bulb A                 | bulb B                 |
|-----|------------------------|------------------------|
| (1) | as bright as 10 units  | unlit                  |
| (2) | brighter than 10 units | unlit                  |
| (3) | as bright as 10 units  | brighter than 10 units |
| (4) | brighter than 10 units | brighter than 10 units |

23. Study the properties of four materials Q, R, S and T given in the table below.

| Material | Properties of materials |                        |          |
|----------|-------------------------|------------------------|----------|
|          | Transparent             | Good Conductor of Heat | Magnetic |
| Q        | No                      | No                     | No       |
| R        | No                      | Yes                    | Yes      |
| S        | No                      | Yes                    | No       |
| T        | Yes                     | No                     | No       |

What could Materials Q, R, S and T be?

|     | Material Q | Material R | Material S | Material T |
|-----|------------|------------|------------|------------|
| (1) | Iron       | Steel      | Copper     | Wood       |
| (2) | Wood       | Iron       | Gold       | Rubber     |
| (3) | Plastic    | Copper     | Iron       | Cotton     |
| (4) | Cotton     | Steel      | Copper     | Glass      |

24. The diagram shows a drawing of a roller coaster ride.

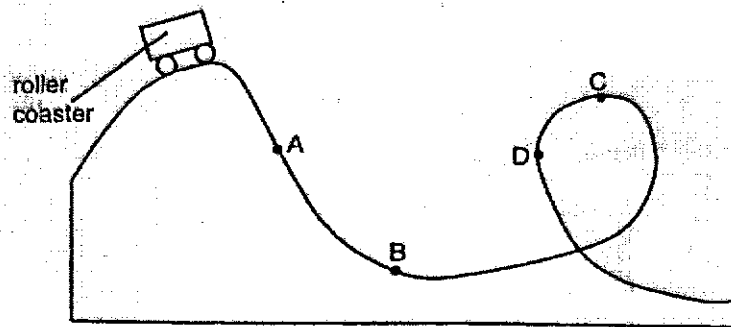

At which one of the four points (A, B, C or D) along the ride would the roller coaster have the most kinetic energy?

- (1) A
  - (2) B
  - (3) C
  - (4) D
25. Which one of the following is not an effect of a force?
- (1) A dented pingpong ball.
  - (2) An angkana fruit falling from the tree.
  - (3) A kite being blown by the wind.
  - (4) A bar of chocolate melting under the Sun.

26. The diagram below shows a toy car. Johari wound it up and released it.

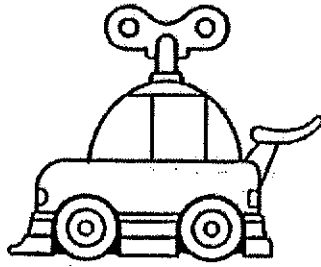

Which of the graphs below illustrates the kinetic energy (KE) and potential energy (PE) in the toy car from the time Johari started to wind the toy car until the toy car came to a stop?

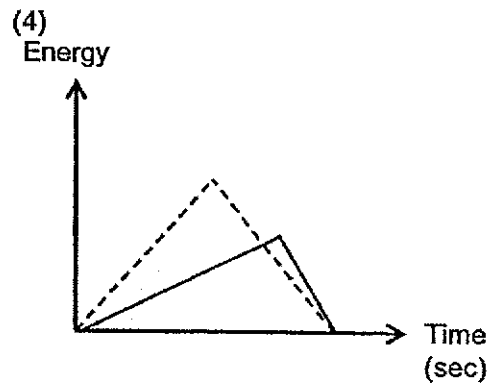
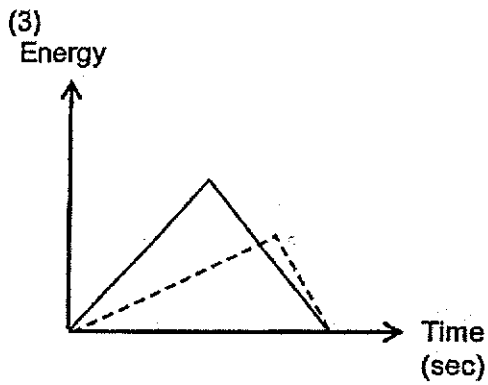
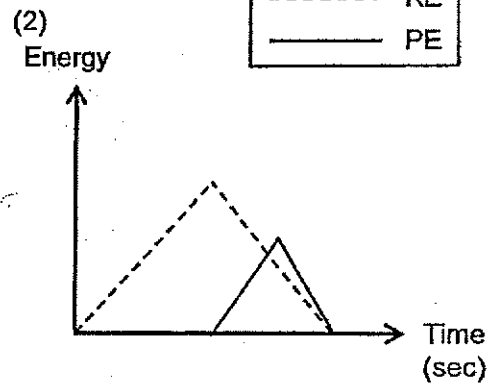
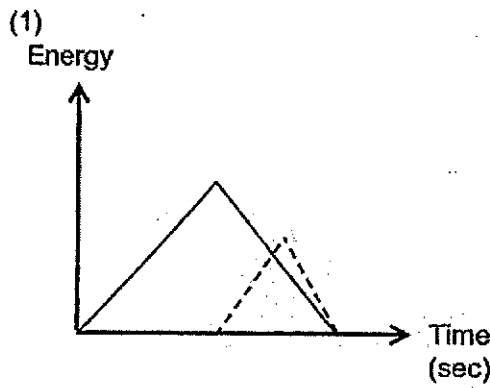
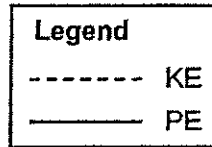

27. The flow chart below shows the process of finding out whether an object is magnetic, non-magnetic or a magnet.

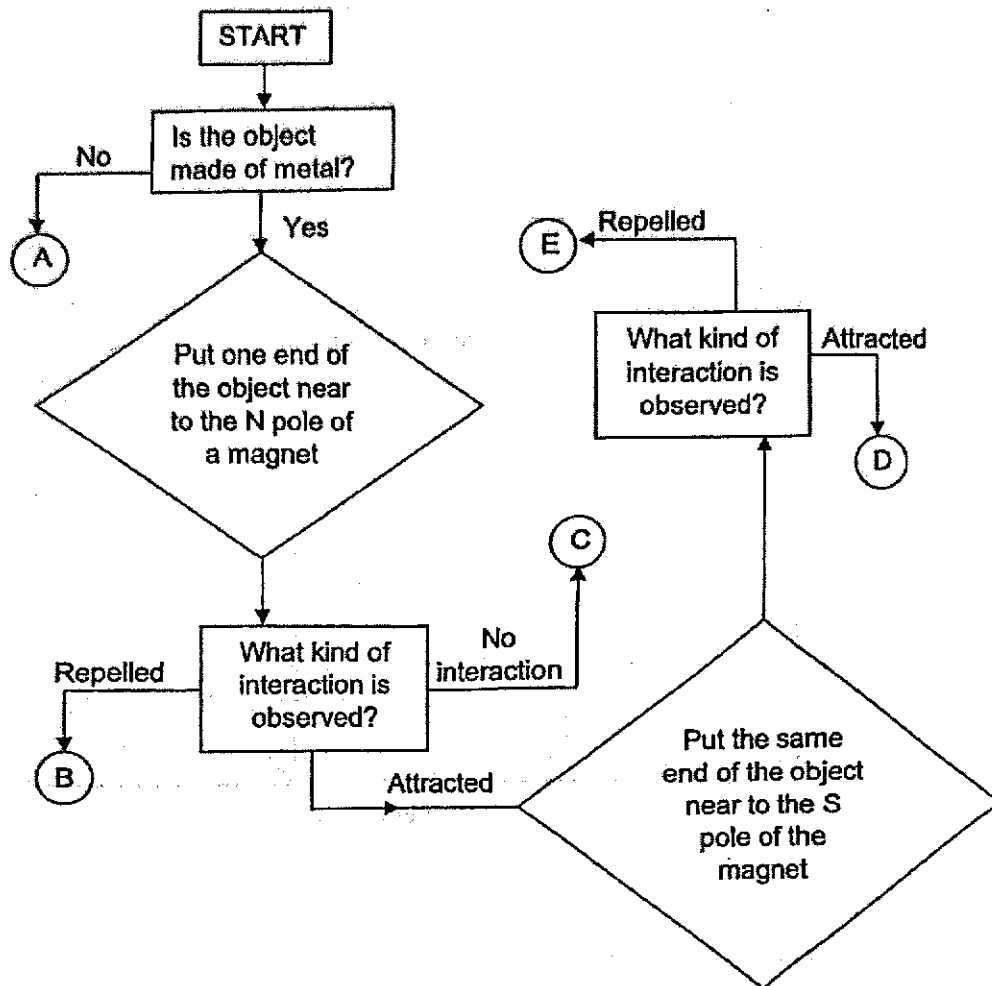

Which of the following sentences is correct?

- (1) A and C both are non-metallic objects.
- (2) B is a stronger magnet than E.
- (3) B and E are magnets while D is a magnetic object.
- (4) A is a non-magnetic object while B and C are magnetic objects.

28. Lionel used the set-up shown below to find the time taken for a wooden block to slide down two different surfaces, A and B.

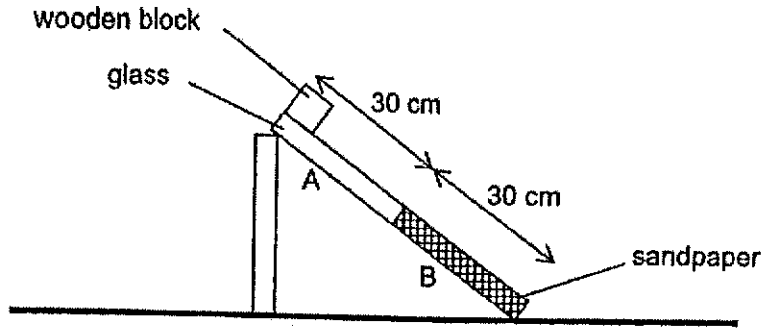

He measured the time taken for the wooden block to slide down each of the two surfaces and recorded the results in a graph.

(1)

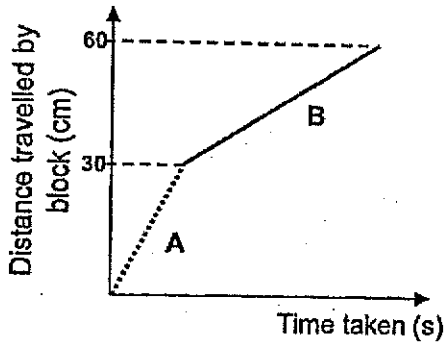

(2)

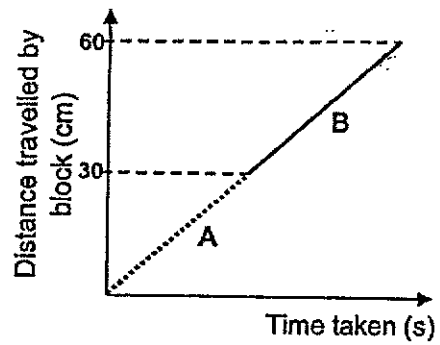

(3)

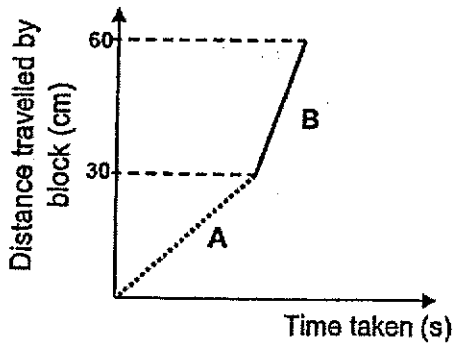

(4)

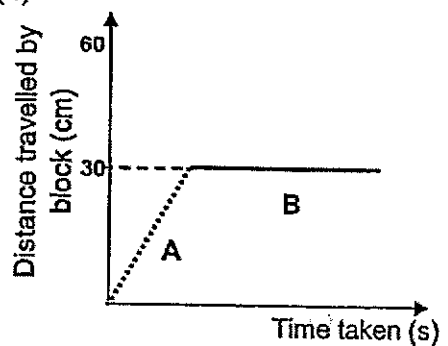

End of Booklet A



Henry Park Primary School  
Primary Six Science  
2024 Term Review 2

Name: \_\_\_\_\_ ( ) Class: 6 \_\_\_ Parent Signature: \_\_\_\_\_

Booklet B (44 marks)

Marks: \_\_\_\_\_ / 44

For questions 29 to 40, write your answers in the space provided. The number of marks available is shown in brackets [ ] at the end of each question or part question.

29 The diagram shows how blood travels in the human body.

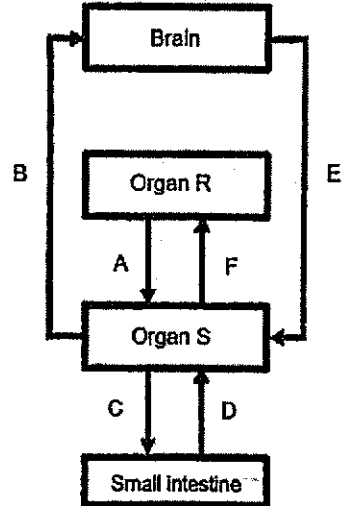

(a) Arrows A, B, C, D, E and F represent the movement of blood. R and S represent two organs. Name organs R and S. [1]

Organ R: \_\_\_\_\_ Organ S: \_\_\_\_\_

(b) The blood at B contains a larger amount of substance X than at E. What is substance X? Explain your answer. [2]

\_\_\_\_\_

\_\_\_\_\_

(c) State the two main functions of the small intestine. [1]

\_\_\_\_\_

\_\_\_\_\_

30 The diagram shows the parts of a human organ system.

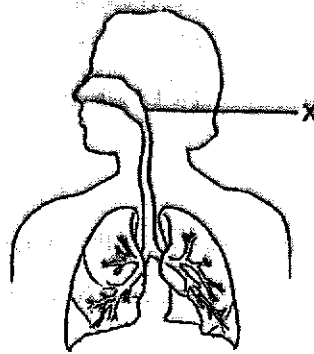

(a) State a useful substance that enters the human body through part X. [1]

---

(b) Describe how carbon dioxide is removed from a person's body. [2]

---

---

---

(c) Why does our breathing rate increase when we exercise? [2]

---

---

---



- 31 Lisa observed two flowers, Q and R and concluded that flowers Q and R are pollinated by wind.

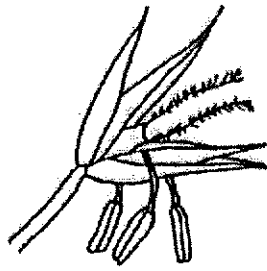

Flower Q

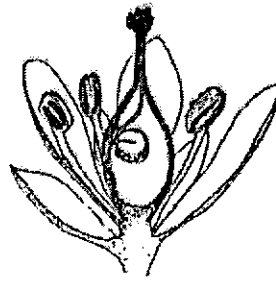

Flower R

- (a) Based on the diagrams above, suggest how Lisa came to her conclusion. [2]

Flower Q:

---



---

Flower R:

---



---

The diagram below shows part of flower P.

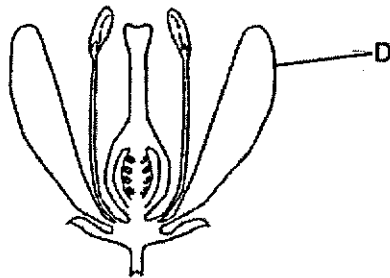

Flower P

- (b) How is part D useful in the reproduction of the plant? [1]

---



---

32 The pictures show two fruits, X and Y.

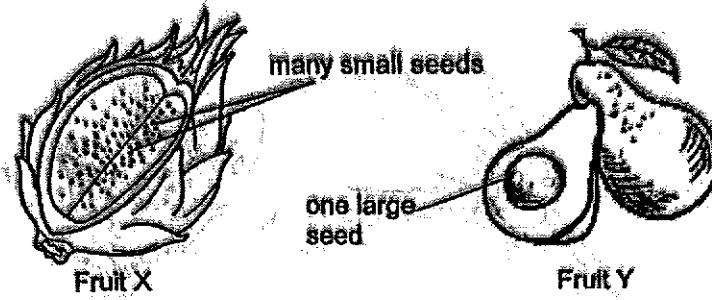

(a) Both fruits are dispersed by animals.  
How are the seeds of fruit X dispersed differently compared to the seeds of fruit Y? [2]

---

---

---

(b) Why do plants disperse their seeds or fruits? [1]

---

---

33 Fatimah conducted an experiment to find out how the amount of water affects the growth of a plant. The diagram below shows each of her set-up in a clear glass tank.

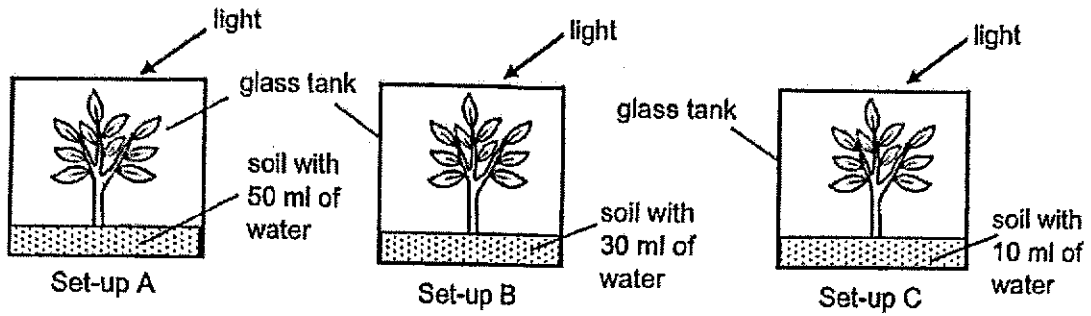

(a) State a hypothesis on how the amount of water affects the growth of a plant. [1]

---

---

(b) In her experiment, Fatimah kept the type of plants the same. How did this make her experiment a fair test? [1]

---

---

(c) Fatimah stated that set-up B was a control for her experiment. State the purpose of the control set-up in this experiment. [2]

---

---

## Question 33 continued

- (d) Suggest what Fatimah should measure to make a conclusion for her experiment. [1]

---

---

- (e) What should Fatimah do to improve the accuracy of her experiment? [1]

---

---

34 Afidah set up the experiment in a dark room as shown below.

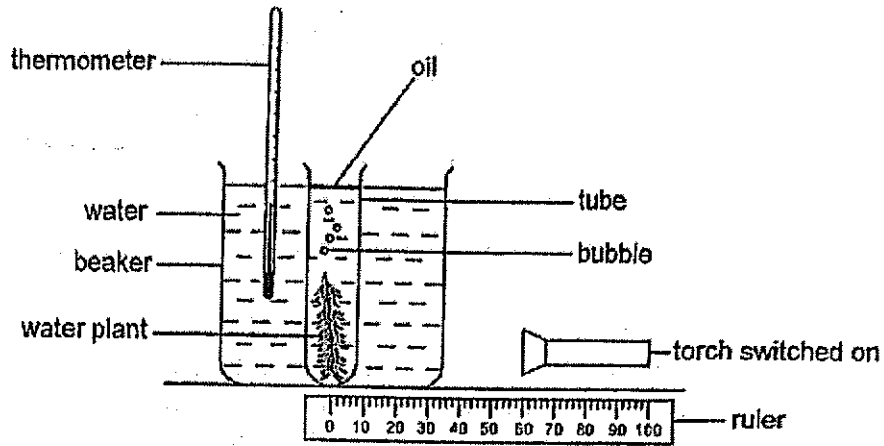

Afidah changed variable X and counted the number of bubbles in the tube. She kept the other variables constant. Her results are shown below.

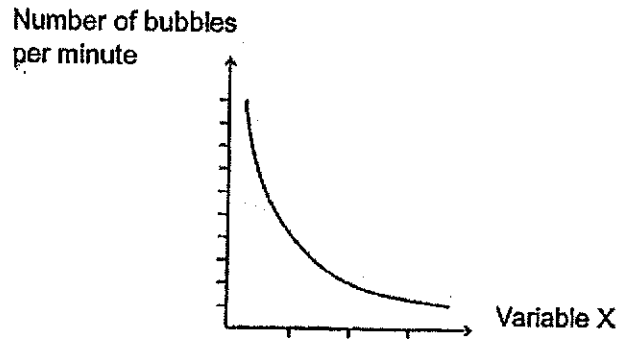

(a) What is variable X? [1]

\_\_\_\_\_

(b) Afidah repeated the experiment by adding some worms in the tube. The number of bubbles formed per minute increased.

Give a reason for her observation. [1]

\_\_\_\_\_  
 \_\_\_\_\_

Question 34 continued

- (c) Explain why switching off the torch would cause the worms to die faster than when the torch was switched on. [1]

---



---

35. Isaac mixed 150 ml of red coloured water with another 150 ml of blue coloured water. 10g of salt was then dissolved in the mixture. The mixture was then heated as shown below. After five minutes, liquid X is formed on the inner side of the funnel.

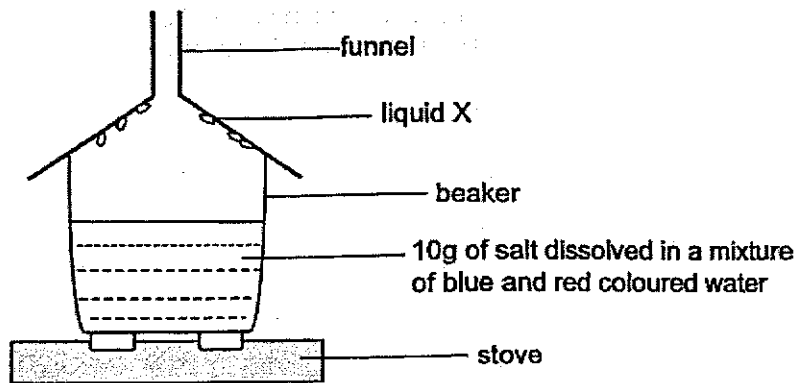

- (a) What is the colour of liquid X? Explain your answer. [1]

---



---

- (b) Isaac wanted to collect more water droplets in a shorter time. His friend suggested that he changed the material of the funnel.

Given that the funnel is made of plastic, what material should Isaac use instead for the funnel? Explain your answer. [1]

---



---

36. Anthony used two batteries, four bulbs, a switch and some wires to set up a circuit as shown below.

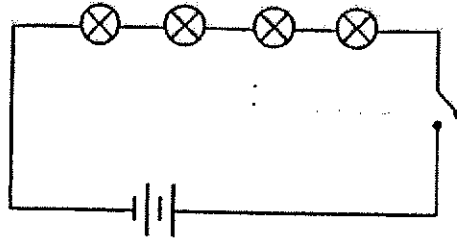

He noticed that all the four bulbs were very dim when the circuit was closed.

- (a) He decided to make some changes to the circuit to make the bulbs brighter.

Put a tick (✓) beside each statement that describes what he should do. [1]

|       |  |  |
|-------|--|--|
| (i)   | He should add more batteries to the circuit. |  |
| (ii)  | He should add another switch to the circuit. |  |
| (iii) | He should remove two bulbs from the circuit. |  |

- (b) After a while, all the lights went out. What could be a possible cause? [1]

---

- (c) Using two batteries, two bulbs, two switches and some wires, draw a circuit diagram in the box below to show how Anthony could construct a circuit which:

- allows a bulb to light up each time a switch is closed.
- allows one bulb to light up even though the other bulb has fused.

[2]

37. Zack set up an experiment in a dark room. He placed four sheets of materials, A, B, C, and D as shown in the diagram below. He then placed a ball on top of a wooden block between material A and B. Zack switched on the torch and a clear dark shadow was cast on material C.

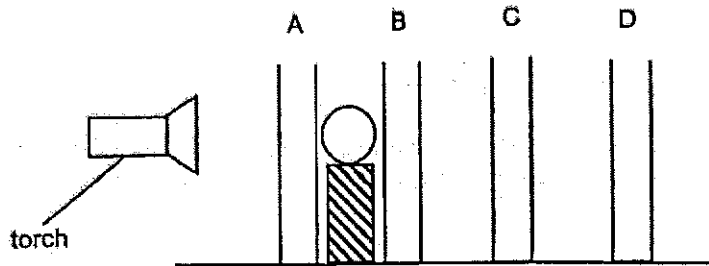

(a) Based on the above observation, Zack drew the following conclusions.

Put a tick (✓) in the appropriate box to indicate if each conclusion is 'True', 'False' or 'Not possible to tell'. [2]

| Conclusion                              | True | False | Not possible to tell |
|---|------|-------|----------------------|
| Material A allows light to pass through | ✓    |       |                      |
| Material B allows light to pass through | ✓    |       |                      |
| Material C allows light to pass through |      | ✓     |                      |
| Material D allows light to pass through |      |       | ✓                    |

(b) State how a shadow is formed. [1]

---



---



38. Jenny placed a beaker of ice cubes on a table in the science laboratory. She then recorded the change in temperature of the ice cubes at an interval of 5 minutes.

| Time (min) | Temperature (°C) |
|------------|------------------|
| 0          | 0                |
| 5          | 0                |
| 10         | 0                |
| 15         | 0                |
| 20         | 1                |
| 25         | 6                |
| 30         | 21               |

- (a) What process was taking place in the first 15 minutes of the experiment? [1]

---

- (b) Why did the temperature increase during the last 15 minutes of the experiment? [1]

---

---

- (c) At which point of time did the ice cubes completely change into another state? [1]

---

39. Joel wound up a toy plane as shown below.

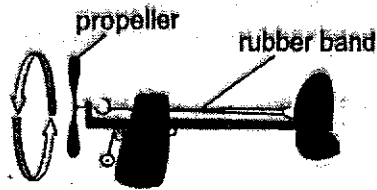

He turned the propeller several rounds and released it. The toy plane moved forward.

(a) Fill in the boxes below to show the energy conversion. [1]



He wound up the plane up and released it into the air as shown below.

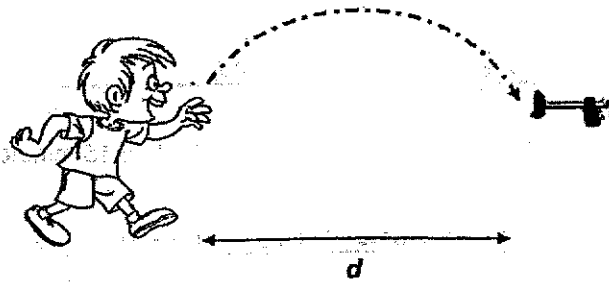

Distance  $d$  refers to how far the toy plane travelled. He repeated the experiment by increasing the number of turns. The table below shows the results of his experiment.

|                  | first try | second try | third try |
|------------------|-----------|------------|-----------|
| number of turns  | 20        | 30         | 40        |
| distance ( $d$ ) | 6 m       | 10 m       | 15 m      |

(b) What is the relationship between the number of turns of the propeller and distance  $d$ ? [1]

---



---

(c) State one change that can be made to the rubber band so that toy plane can travel further. Give a reason for your answer. [1]

---



---

40. Ethan wanted to find out which rubber band, S or T, can be stretched more easily. The graph shows how the length of two rubber bands, S and T, increased when weights were hung on them.

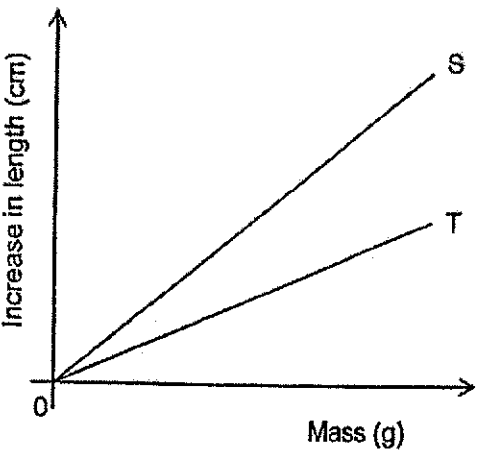

(a) Based on the graph, which rubber band, S or T, can be stretched more easily? Give a reason for your answer. [1]

---

---

Question 40 continued

The diagram shows <sup>Shawn</sup> a man bungee jumping. He is attached to a long rubber cord as he jumps off a bridge.

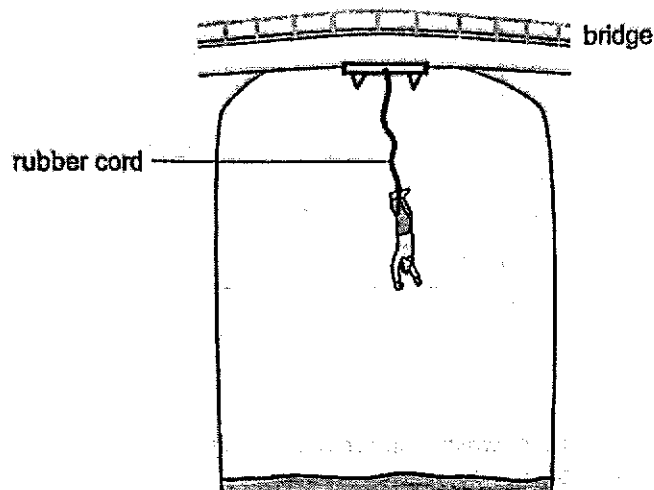

When he jumped off the bridge, he fell downwards into the air very quickly for a few seconds. Suddenly, he felt a pull on his legs, and he was pulled up to mid-air. He then went downwards again. This continued for a few times until he came to a stop.

- (b) Why did Shawn fall downwards into the air very quickly once he jumped off the bridge? [1]

---



---

- (c) Identify the force(s) acting on Shawn when he was pulled up and down a few times before he came to a stop at mid-air. [1]

---

- (d) What is the property of the rubber cord that enabled Shawn to be pulled up and down? [1]

---

Question 40 continued

The diagram below shows two groups of children playing tug-of-war. Each group needs to get the ribbon on the rope over to their side in order to win.

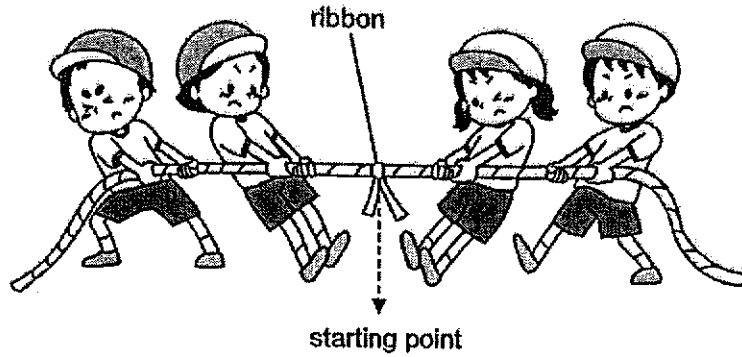

- (e) Why is the ribbon still at the starting point even though both groups have been pulling the rope for some time? [1]

---

---

End of Booklet B



**CHOOL : HENRY PARK PRIMARY SCHOOL**  
**LEVEL : PRIMARY 6**  
**SUBJECT : SCIENCE**  
**TERM : 2024 WA2**

|     |     |     |     |     |     |     |     |     |     |
|-----|-----|-----|-----|-----|-----|-----|-----|-----|-----|
| Q1  | Q2  | Q3  | Q4  | Q5  | Q6  | Q7  | Q8  | Q9  | Q10 |
| 4   | 2   | 4   | 2   | 2   | 1   | 3   | 2   | 1   | 2   |
| Q11 | Q12 | Q13 | Q14 | Q15 | Q16 | Q17 | Q18 | Q19 | Q20 |
| 3   | 2   | 1   | 2   | 3   | 3   | 1   | 2   | 2   | 3   |
| Q21 | Q22 | Q23 | Q24 | Q25 | Q26 | Q27 | Q28 |     |     |
| 2   | 4   | 4   | 2   | 4   | 1   | 3   | 1   |     |     |

|      |   |
|------|---|
| Q29) | <p>a) Organ R: Lungs      Organ S: Heart</p> <p>b) At B, the blood is coming from the lungs and the heart so it has a larger amount of oxygen. However at E, some of the oxygen in the blood has already been used by Brain.</p> <p>c) Absorb digested food into the bloodstream and finish the digestion of food.</p>  |
| Q30) | <p>a) Oxygen .</p> <p>b) Blood rich in carbon dioxide would be transported to the heart which would then be transported to the lungs. The carbon dioxide would be removed from the body when we exhale.</p> <p>c) When we exercise our cells need more energy so we need to take in more oxygen and produce more carbon dioxide. Thus, more energy is produced.</p> |
| Q31) | <p>a) Flower Q: pollen grains are blown away easily by wind.<br/>Flower R: pollen grains will land more easily on stigma.</p> <p>b) It has bright colours to attract more insects to pollinate flower P.</p>  |

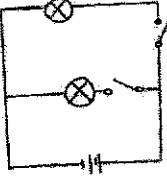
|      |   |
|------|---|
| Q32) | <p>a) The seeds of fruit X will be eaten by the animal and will come out as waste . However, the seed of fruit Y is thrown away after the animal eats as it is too large to be swallowed.</p> <p>b) To prevent overcrowding and reduce competition between the parent and young plant for space, sunlight, water and minerals.</p> <p>c)</p>  |
| Q33) | <p>a) The set-up containing the most amount of water will grow the fastest.</p> <p>b) So that only the amount of water in each set-up would affect the growth of the plant and no other factors.</p> <p>c) To compare growth of plants in the three set-ups ensure that nothing besides the amount of water will affect the growth of the plant.</p> <p>d) She must calculate difference in height of each plant.</p> <p>e) Increase differences between amount of water given to three plants.</p> |
| Q34) | <p>a) Distance between the torch and water plant.</p> <p>b) When the worms respire, they produce carbon dioxide. Since there is more carbon dioxide present the plant takes in more carbon dioxide and photosynthesis faster, producing, forming the bubbles.</p> <p>c) Water plant cannot photosynthesis<br/>→ Insufficient oxygen → worm dies</p>   |
| Q35) | <p>a) Colourless. Only pure water can evaporate, so the colour would not be present in liquid X.</p> <p>b) Metal. Metal is a better conductor of heat than plastic. So the water vapour can lose heat and condense faster to form water droplets.</p>   |
| Q36) | <p>a)i), iii)</p> <p>b) One of the bulbs fused, causing an open circuit. So electric current cannot flow through.</p> <p>c)</p>    |



| Q37)                                    | <p>a)</p> <table border="1" data-bbox="363 264 1152 501"> <thead> <tr> <th data-bbox="363 264 762 320">Conclusion</th> <th data-bbox="762 264 866 320">True</th> <th data-bbox="866 264 970 320">False</th> <th data-bbox="970 264 1152 320">Not possible to tell</th> </tr> </thead> <tbody> <tr> <td data-bbox="363 320 762 365">Material A allows light to pass through</td> <td data-bbox="762 320 866 365">✓</td> <td data-bbox="866 320 970 365"></td> <td data-bbox="970 320 1152 365"></td> </tr> <tr> <td data-bbox="363 365 762 409">Material B allows light to pass through</td> <td data-bbox="762 365 866 409">✓</td> <td data-bbox="866 365 970 409"></td> <td data-bbox="970 365 1152 409"></td> </tr> <tr> <td data-bbox="363 409 762 454">Material C allows light to pass through</td> <td data-bbox="762 409 866 454"></td> <td data-bbox="866 409 970 454">✓</td> <td data-bbox="970 409 1152 454"></td> </tr> <tr> <td data-bbox="363 454 762 501">Material D allows light to pass through</td> <td data-bbox="762 454 866 501"></td> <td data-bbox="866 454 970 501"></td> <td data-bbox="970 454 1152 501">✓</td> </tr> </tbody> </table> <p>b) When light is blocked by an object a shadow is formed.</p> | Conclusion | True                 | False | Not possible to tell | Material A allows light to pass through | ✓ |  |  | Material B allows light to pass through | ✓ |  |  | Material C allows light to pass through |  | ✓ |  | Material D allows light to pass through |  |  | ✓ |
|---|--|------------|----------------------|-------|----------------------|---|---|--|--|---|---|--|--|---|--|---|--|---|--|--|---|
| Conclusion                              | True   | False      | Not possible to tell |       |                      |   |   |  |  |   |   |  |  |   |  |   |  |   |  |  |   |
| Material A allows light to pass through | ✓  |            |                      |       |                      |   |   |  |  |   |   |  |  |   |  |   |  |   |  |  |   |
| Material B allows light to pass through | ✓  |            |                      |       |                      |   |   |  |  |   |   |  |  |   |  |   |  |   |  |  |   |
| Material C allows light to pass through |  | ✓          |                      |       |                      |   |   |  |  |   |   |  |  |   |  |   |  |   |  |  |   |
| Material D allows light to pass through |  |            | ✓                    |       |                      |   |   |  |  |   |   |  |  |   |  |   |  |   |  |  |   |
| Q38)                                    | <p>a) Melting.<br/> b) The ice cubes have already melted into water, so all of the heat gained is to increase the temperature of the water.<br/> c) 20 min</p>   |            |                      |       |                      |   |   |  |  |   |   |  |  |   |  |   |  |   |  |  |   |
| Q39)                                    | <p>a) kinetic energy → kinetic energy<br/> b) As the number of turns increases, the distance d increases.<br/> c) Use a stiffer rubber band. More elastic potential energy stored in rubber band will be converted into more kinetic energy for the plane to fly further.</p>  |            |                      |       |                      |   |   |  |  |   |   |  |  |   |  |   |  |   |  |  |   |
| Q40)                                    | <p>a) Rubber band S. Rubber band S increased in length more than T when the same mass was hung on it.<br/> b) Gravitational force pulls him towards the centre of the earth.<br/> c) Elastic spring force.<br/> d) Elastic<br/> e) The same amount of force is present pulling the rope on both sides. So the rope would not move.</p>   |            |                      |       |                      |   |   |  |  |   |   |  |  |   |  |   |  |   |  |  |   |

