

Tao Nam School
P6 Science Timed practice

Name : _____

Date : _____

Class : P6 ()

For each question from 1 to 28, four options are given. One of them is the correct answer. Make your choice (1, 2, 3 or 4) and shade your answer on the Optical Answer Sheet.

(56 marks)

- 1 The diagrams show two animals.



How are the animals similar?

- (1) lay eggs
 - (2) have scales
 - (3) have moist skin
 - (4) have a four-stage life cycle
- 2 Which of the following shows the correct direction of food that is taken through the mouth?
- (1) stomach, small intestine, large intestine, gullet
 - (2) stomach, gullet, small intestine, large intestine
 - (3) gullet, stomach, large intestine, small intestine
 - (4) gullet, stomach, small intestine, large intestine
- 3 Which statement about the human digestive system is correct?
- (1) Some food has been digested when it leaves the stomach.
 - (2) The large intestine does not absorb any substance.
 - (3) The large intestine digests and absorbs food.
 - (4) The mouth does not digest food.

3

- 4 The diagram shows a plant cell.

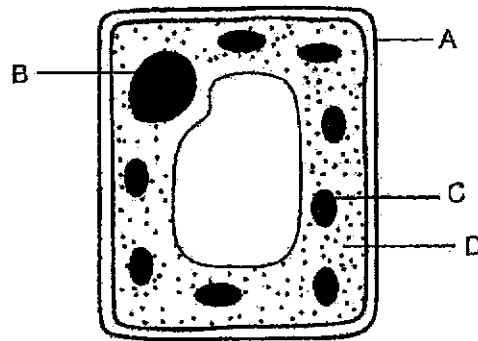

- Which parts are also found in an animal cell?
- (1) A and B
 - (2) A and C
 - (3) B and D
 - (4) C and D
- 5 Moss is a tiny non-flowering plant. It grows well at the bottom of tree trunks in forests.

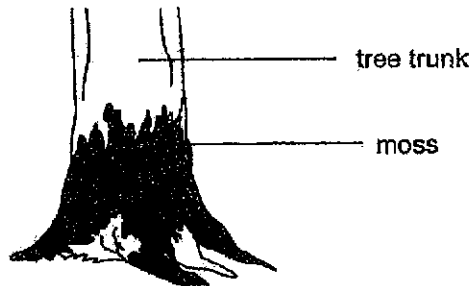

A gardener wants to grow moss in a garden. How can he help the moss grow well?

- (1) water the moss daily
- (2) attract butterflies to the garden
- (3) grow the moss under bright sunlight
- (4) attract animals that help disperse fruits

(Go on to the next page)

- 6 The table shows the types of gases in air that are taken in and given out by a human.

Gas	Air taken in (%)	Air given out (%)
nitrogen	78	78
oxygen	21	16
carbon dioxide	less than 1	4
water vapour	less than 1	2

Based on the information given, which statement is not correct?

- (1) Carbon dioxide produced by the body is released into the air.
 (2) All the oxygen that enters the lungs goes into the blood.
 (3) At least four types of gases enter the respiratory system.
 (4) Water is lost through breathing.
- 7 Which of the following do plants need to carry out photosynthesis?

- A tiny openings on leaves
 B chloroplasts
 C food carrying tubes
 D water carrying tubes

- (1) A and C only
 (2) B and D only
 (3) A, B and C only
 (4) A, B and D only
- 8 What is the state of water when it is taken in and when it is given out by a plant?

	Taken in	Given out
(1)	liquid	liquid
(2)	gas	gas
(3)	liquid	gas
(4)	gas	liquid

5

- 9 The graph shows the amount of rain in country W every year.

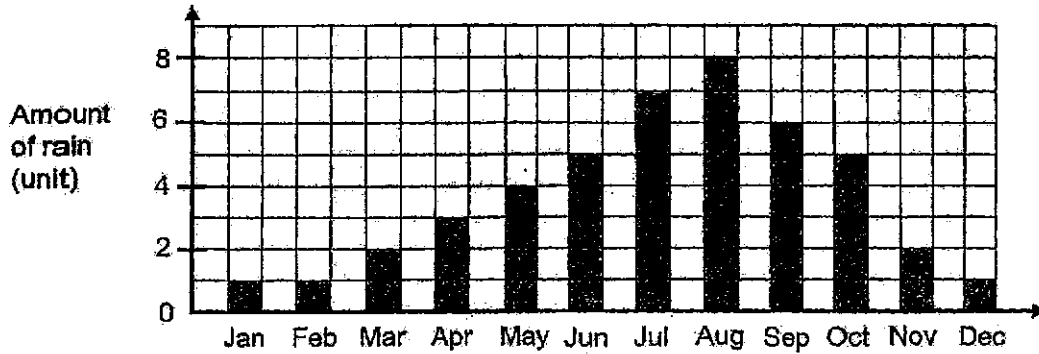

The table shows some information about the growth of rice and barley.

	Rice	Barley
Time to become adult plants (months)	5	4
Amount of rain suitable for growth (unit)	5 or more	2 or less

Which plant(s) can grow in country W?

- (1) rice only
 - (2) barley only
 - (3) both barley and rice
 - (4) neither barley nor rice
- 10 Sami observed the change in a plant.

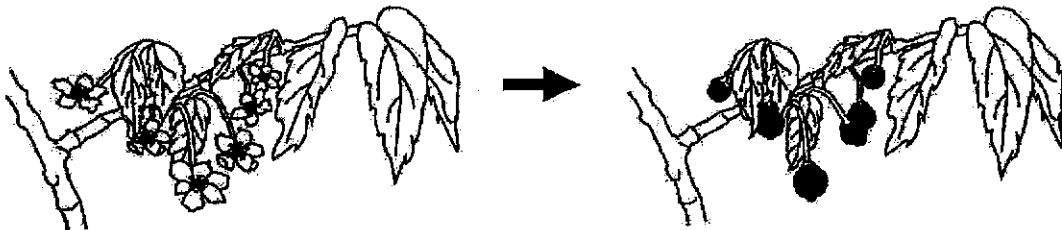

Which process(es) took place?

- (1) pollination only
- (2) pollination and fertilisation only
- (3) fertilisation and dispersal only
- (4) fertilisation, dispersal and germination only

(Go on to the next page)

6

- 11 Ken has two identical pots of plant P. He placed one plant in a room at 30 °C and the other at 40 °C. On each plant, he clipped dry pieces of a type of paper to the upper and lower surfaces of a leaf as shown. The paper turns pink when wet.

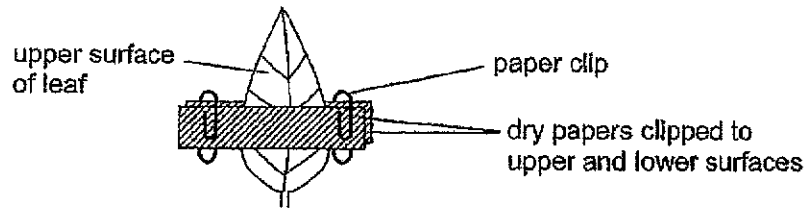

The graph shows the time taken for the paper to turn pink.

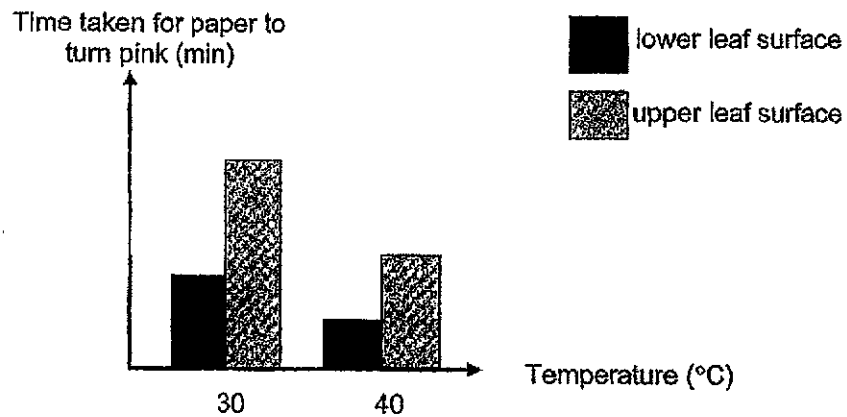

Based on the graph, which statement is a correct conclusion?

- (1) Plant P at 30 °C lost more water.
 - (2) Plant P at 40 °C has fewer openings on its leaves.
 - (3) Plant P has more openings on the upper surface of its leaves.
 - (4) Plant P lost water more quickly through the lower surface of its leaves.
- 12 Blood flows through blood vessels A to D as shown.



Which blood vessels transport blood richer in oxygen?

- (1) A and B only
- (2) A and D only
- (3) B and C only
- (4) C and D only

7

- 13 Kim cut a root into pieces of the same size. She placed each piece into a glass tube. Each tube was kept at a different temperature.

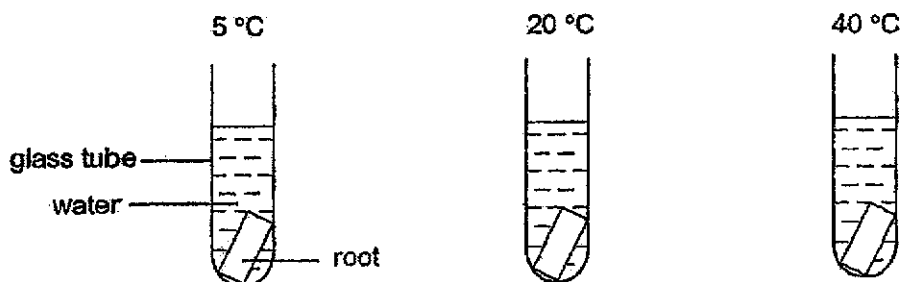

The root cells contained a red substance.

After some time, Kim observed the colour of the water in the tubes. The table shows her results.

Temperature of water (°C)	Colour of water
5	light pink
20	pink
40	dark pink

Which of the following explains her observation?

	Temperature change	Effect on root cells
(1)	decreased	cell wall prevented more red substance from moving out
(2)	increased	cell wall prevented more red substance from moving out
(3)	decreased	cell membrane allowed more red substance to move out
(4)	increased	cell membrane allowed more red substance to move out

(Go on to the next page)

14 Study the chart below.

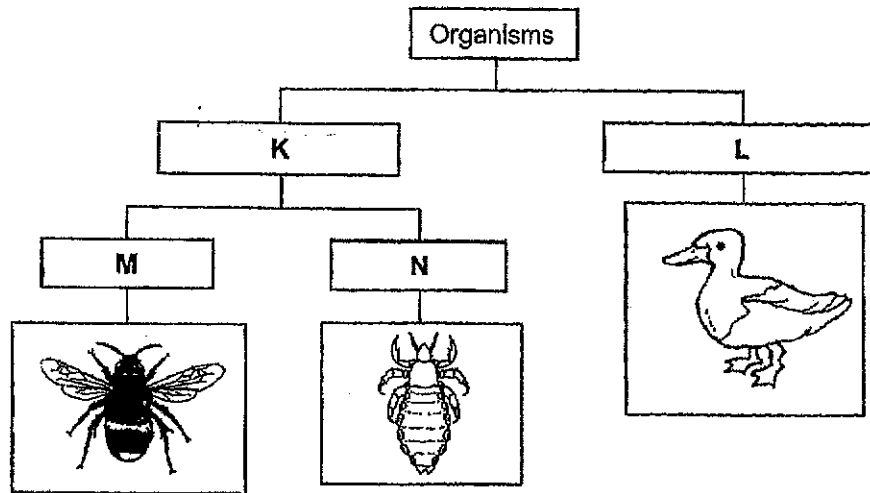

Which of the following is correct for K, L, M and N?

	K	L	M	N
(1)	No feathers	Has feathers	Lay eggs	Does not lay eggs
(2)	3 pairs of legs	Fewer than 3 pairs of legs	Has wings	No wings
(3)	No beak	Has beak	Does not lay eggs	Lay eggs
(4)	Does not lay eggs	Lay eggs	More than 3 pairs of legs	3 pairs of legs

- 15 A container is used to transport heavy objects.

The material for making the container must be _____.

- (1) flexible
- (2) strong
- (3) transparent
- (4) waterproof

- 16 Which of the following shows the properties of a gas?

	shape	volume
(1)	fixed	fixed
(2)	fixed	not fixed
(3)	not fixed	fixed
(4)	not fixed	not fixed

- 17 Study the circuit.

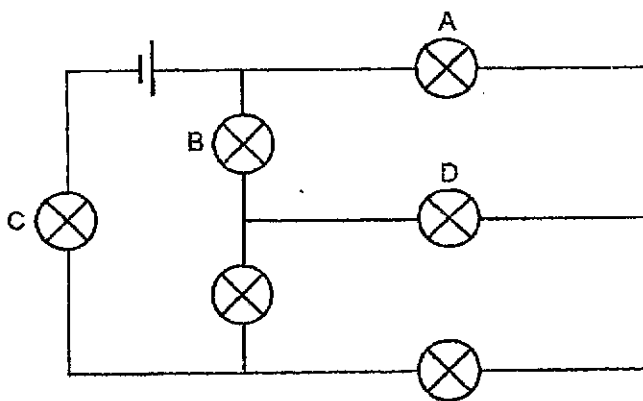

When one bulb was blown, the other bulbs did not light up.
Which bulb was blown?

- (1) A
- (2) B
- (3) C
- (4) D

(Go on to the next page)

- 18 Yiping put an ice cube at the bottom of a tube of water. He heated the water near the top as shown.

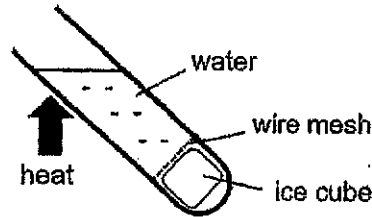

After some time, the water near the top started to boil. However, the ice cube did not melt.

Which statement best explains why the ice cube did not melt?

- (1) Heat flowed only in the upward direction.
 - (2) Heat was used up to boil the water near the top.
 - (3) Heat passed through the water very slowly to the ice cube.
 - (4) The melting point of the ice cube was higher than the boiling point of water.
- 19 Four rings, F, G, H and J, are placed one at a time on a holder. Among the four rings, two are ring magnets and two are iron rings. The observation is as shown.

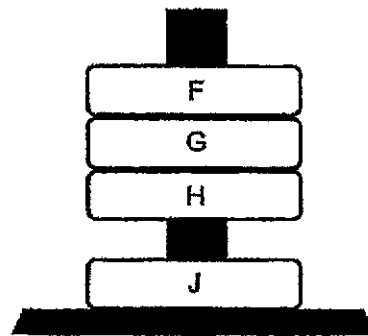

Which two are the iron rings?

- (1) F and G
- (2) F and J
- (3) G and H
- (4) H and J

20 When water changes from gas to liquid at $100\text{ }^{\circ}\text{C}$, which of the following is correct?

- (1) The water is boiling.
- (2) The water gains heat from the surroundings.
- (3) The water loses heat to the surroundings.
- (4) There is no heat gain or loss by the water.

21 Identical bulbs, R, S and T, are used in the circuit.

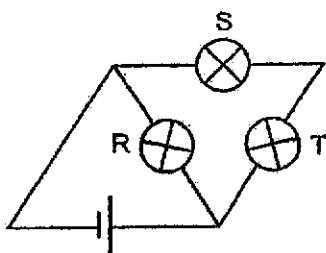

Which change will allow all bulbs to light up with equal brightness?

- (1) Increase the number of batteries
- (2) add an identical bulb in series with R
- (3) add an identical bulb in parallel with R
- (4) add an identical bulb in series with S and T

(Go on to the next page)

- 22 In the set-up, a compressed spring was used to push a block. The block would then slide along the table top before stopping.

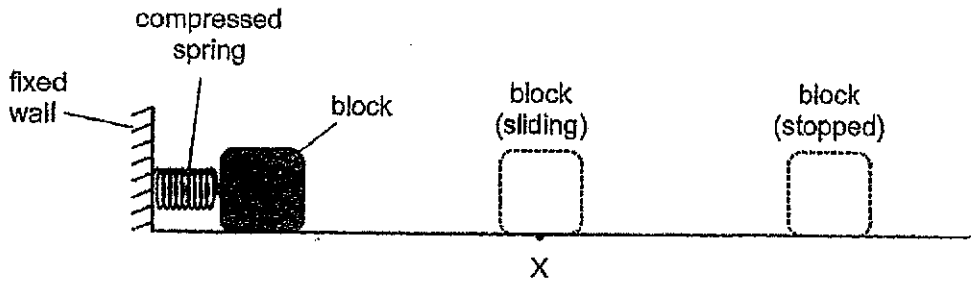

Which force(s) acted on the sliding block at X?

	Elastic spring force	Gravitational force	Frictional force
(1)	yes	yes	yes
(2)	yes	no	yes
(3)	no	yes	no
(4)	no	yes	yes

- 23 In the set-up, the metal ball is free to move in a metal holder but cannot come out.



Which of the following is a possible way to take the ball out?

- (1) add oil to the ball
- (2) heat the ball only
- (3) heat the holder only
- (4) heat both the ball and the holder

- 24 Xiaoming observed four solid blocks made of materials A, B, C and D. He classified them as shown.

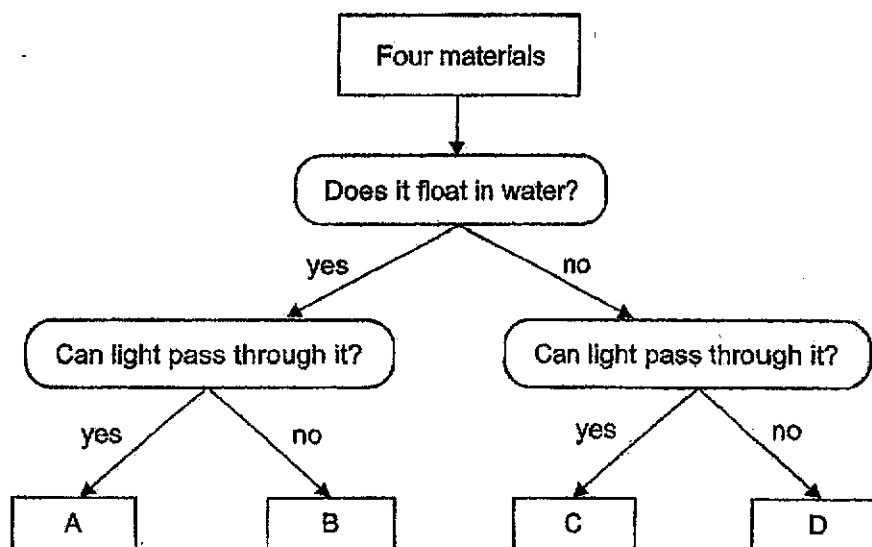

One of the materials is a metal. Which material is metal?

- (1) A
 (2) B
 (3) C
 (4) D
- 25 The table shows the melting and boiling points of substances P and Q.

Substance	P	Q
Melting point (°C)	180	170
Boiling point (°C)	423	210

At which temperature are substances P and Q in different states of matter?

- (1) 150 °C
 (2) 200 °C
 (3) 350 °C
 (4) 450 °C

(Go on to the next page)

- 26 Johnny set up the following experiment in a dark room. The light sensor S on screen Y gave a reading of 50 units.

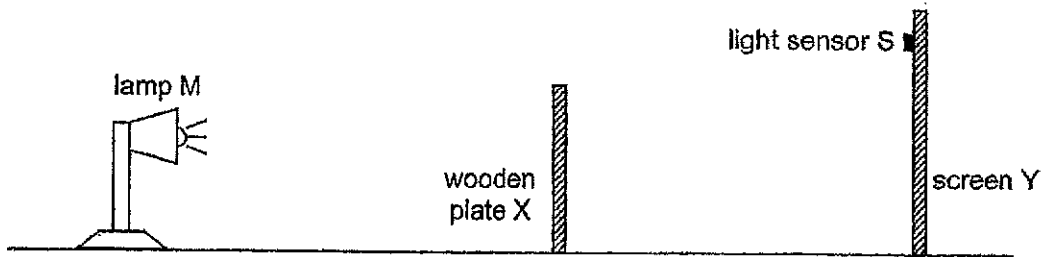

As Johnny moved one object in the set-up, the reading on S decreased slowly to 40 units and then dropped to 0 units suddenly.

Which object did Johnny move and in which direction?

- (1) lamp M towards plate X
 - (2) lamp M away from plate X
 - (3) plate X towards lamp M
 - (4) screen Y away from plate X
- 27 Set-ups P and Q were placed on a table. They contained equal amounts of water at 25 °C and equal amounts of ice cubes. The beaker in set-up P was wider.

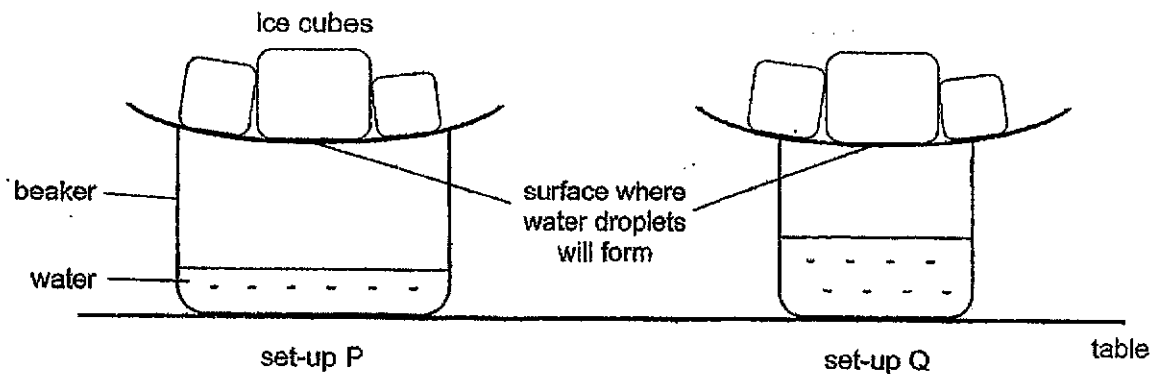

After a while, more water droplets formed in set-up P. Which statement explains this observation?

- (1) More water evaporated because the water was warmer.
- (2) More water vapour condensed because the ice cubes were colder.
- (3) More water evaporated because the exposed surface area of water was larger.
- (4) More water vapour condensed because there was less air movement in the beaker.

- 28 Sarah used a battery, an iron rod and wires to set up an electromagnet. She tested the electromagnet with a magnet. Her observation is shown in Diagram 1.

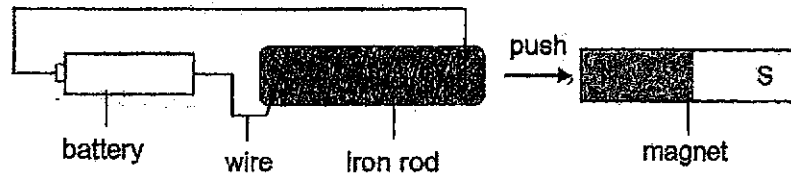

Diagram 1

Her teacher said, "When the battery is connected in the opposite direction, the poles of the electromagnet will change."

When compared to Diagram 1, which observation supports her teacher's statement?

(1)	
(2)	
(3)	
(4)	

Tao Nan School
P6 Science Timed Practice

Name: _____
Class: P6L)

Date: _____

For questions 29 to 40, write your answers in this booklet.

The number of marks available is shown in brackets [] at the end of each question or part question.
(44 marks)

29 The diagram shows a human body system.

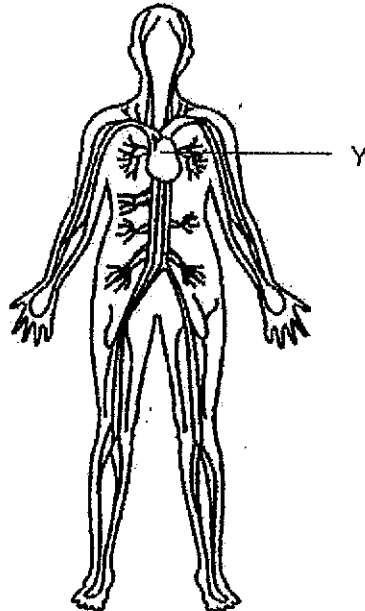

Section A	56
Section B	44
Total	100

(a) Identify the system and state the function of this system. [2]

(b) Name Y. [1]

(c) Other than Y, name another two parts of this system. [1]

(Go on to the next page)

SCORE	4
-------	---

30 The diagram shows fruits E and F.



E

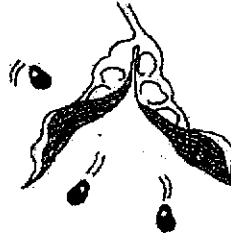

F

(a) How are the seeds of E and F dispersed? [1]

E _____

F _____

(b) State one advantage of the method used by F to disperse its seeds. [1]

(c) John conducted an experiment to find out if the amount of wind affects the distance moved by E as shown.

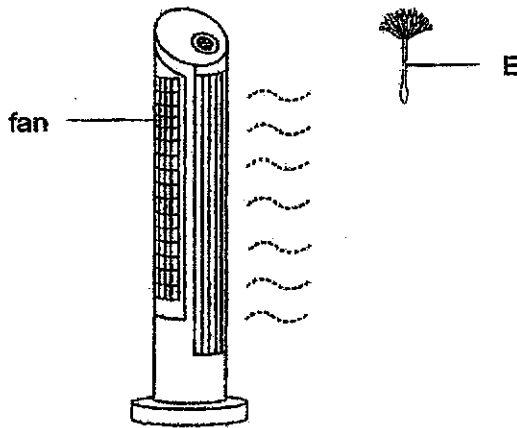

John repeated the experiment five times with all factors kept the same except for one. Suggest two possible ways of varying this factor. [2]

SCORE	4
-------	---

- 31 The diagram shows how substances are transported in a plant. P and Q represent different parts of the plant. The arrows represent the movement of substances G and H.

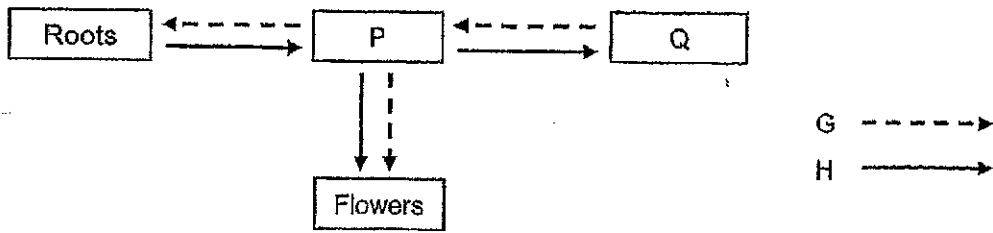

- (a) Identify parts P and Q. [1]
- P _____
- Q _____
- (b) Identify substances represented by H and describe how these substances move in the plant. [2]

(Go on to the next page)

SCORE	3
-------	---

32 (a) Oil is sprayed on stagnant water as shown.

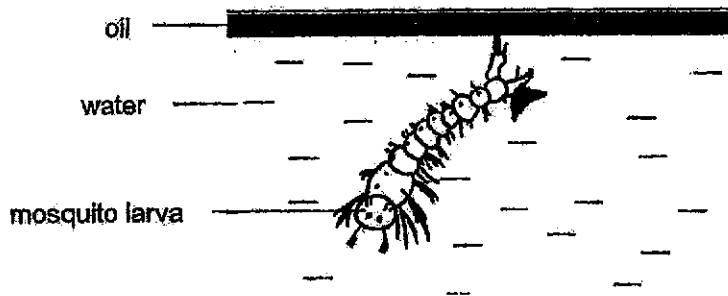

Explain how this prevents mosquito from breeding. [1]

(b) Malaria is a disease spread by mosquito A. Children infected with malaria are found to be bitten more often by mosquito A.

Joel wanted to find out if children infected with malaria are more attractive to mosquito A due to a certain smell that they produce. He used the set-up shown with 20 of mosquito A in box P.

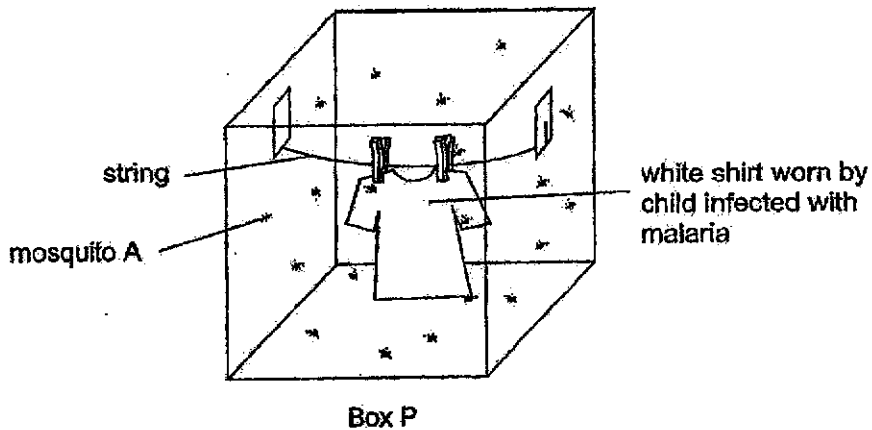

Joel counted the number of times mosquitoes landed on the shirt for 3 minutes. He repeated the experiment using another shirt worn by an uninfected child in box Q.

(i) State a hypothesis on how the smell on a shirt affects its attractiveness to mosquito A. [1]

7

- (ii) Joel used a white shirt instead of a black shirt for the experiment. Suggest why using a white shirt allows him to obtain more accurate results. [1]
-
-

- (iii) Joel recorded his results in the table.

	Number of times mosquitoes landed
Shirt in box P	300
Shirt in box Q	120

Scientists are able to store the smell produced by infected people in a container. Suggest how Joel could use this smell and his results to reduce the number of bites on people. [1]

(Go on to the next page)

SCORE	/
	4

33 Bees are commonly found near flowering plants.

(a) Describe how bees help plants to reproduce. [1]

Jia Xuan investigated the effect of substance N on bees with two containers, R and S, of the same size using a circular cage.

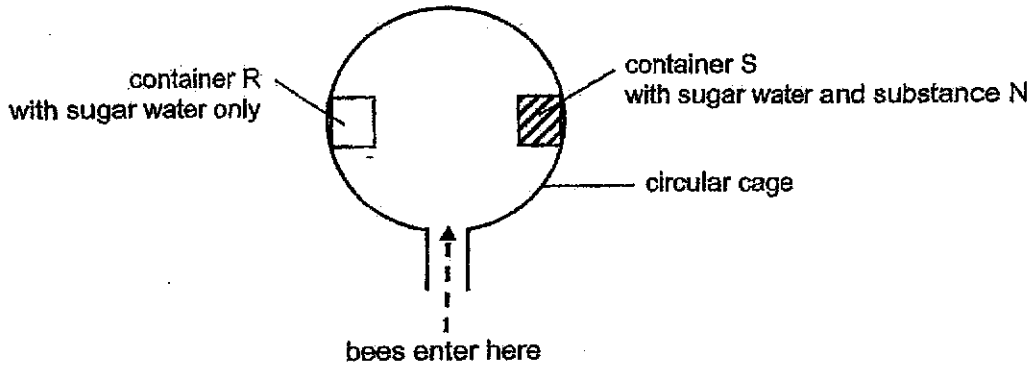

Jia Xuan introduced bees into the cage and closed the opening. She counted the number of times bees visited each container for a duration of 3 hours on Day 1, Day 5 and Day 10.

(b) Suggest how the arrangement of containers in the cage allowed for a fair test. [1]

The number of times bees visited both containers on Day 1, Day 5 and Day 10 are shown.

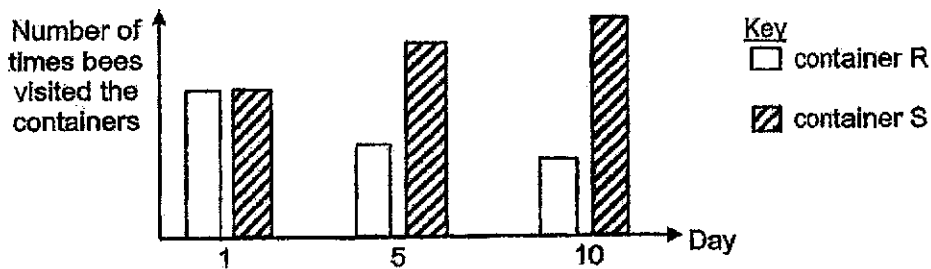

(c) Describe how substance N affected the number of times bees visited both containers from Day 1 to Day 10. [2]

SCORE	4
-------	---

34 Jayden placed the same amount of pond water which contained tiny organisms into two identical glass containers, A and B. He painted container B black.

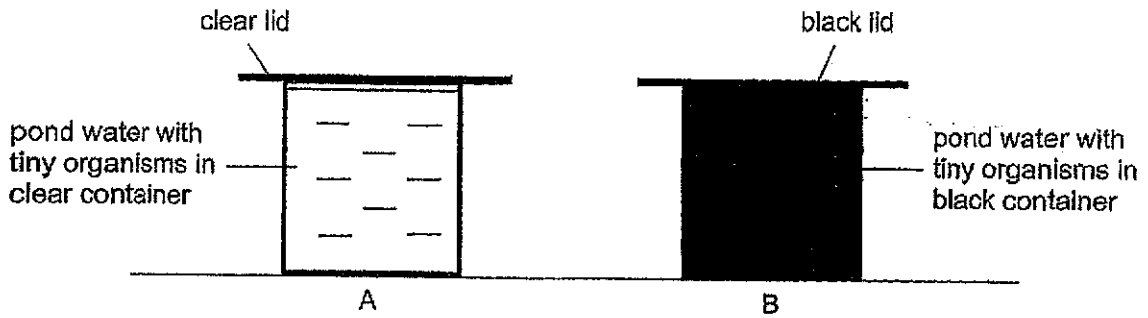

He placed both containers at the same place under bright light. He measured the amount of oxygen in each container daily. His results are as shown.

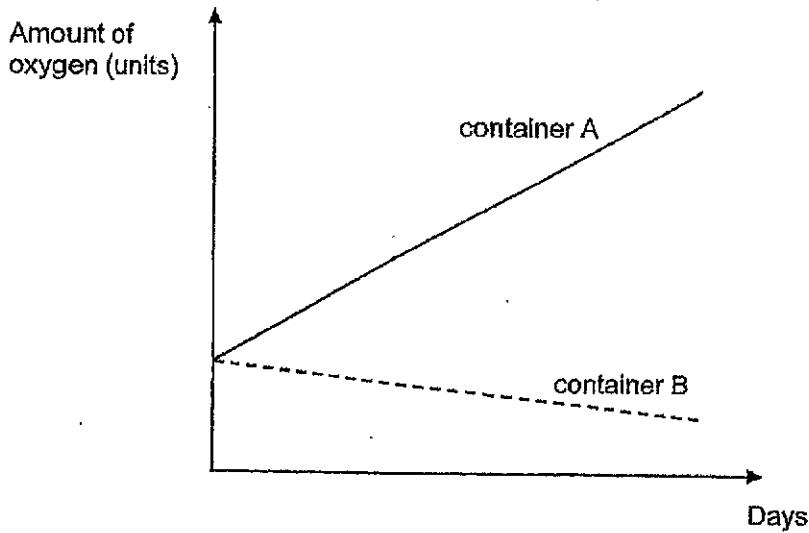

(a) Explain why the amount of oxygen in container A increased while the amount of oxygen in container B decreased. [2]

(b) Suggest one possible reason that could have resulted in Jayden obtaining inaccurate results. [1]

(Go on to the next page)

SCORE	3
-------	---

35 Sylvia boiled some water in a pot on a stove.

(a) State what boiling means. [1]

(b) Sylvia wanted to cook some eggs at 80 °C. When the water boiled, she removed the pot from the stove and added some cold water. She then put in some eggs and covered the pot for 10 minutes.

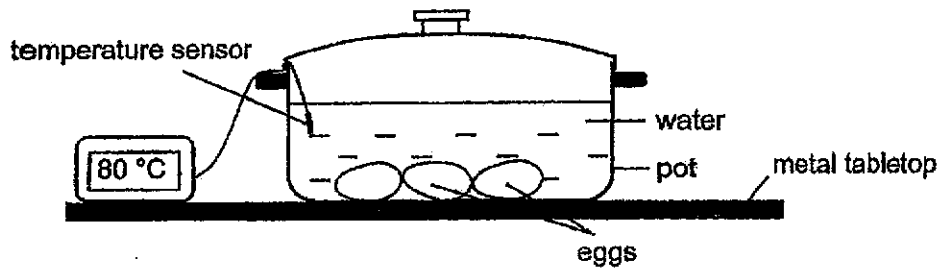

Without reheating the pot, suggest two ways that Sylvia can make sure that water was kept at about 80 °C in the same pot. [2]

SCORE	3
-------	---

36 Ravi rolled a metal ball from point X at a low speed past a strong magnet on a table as shown.

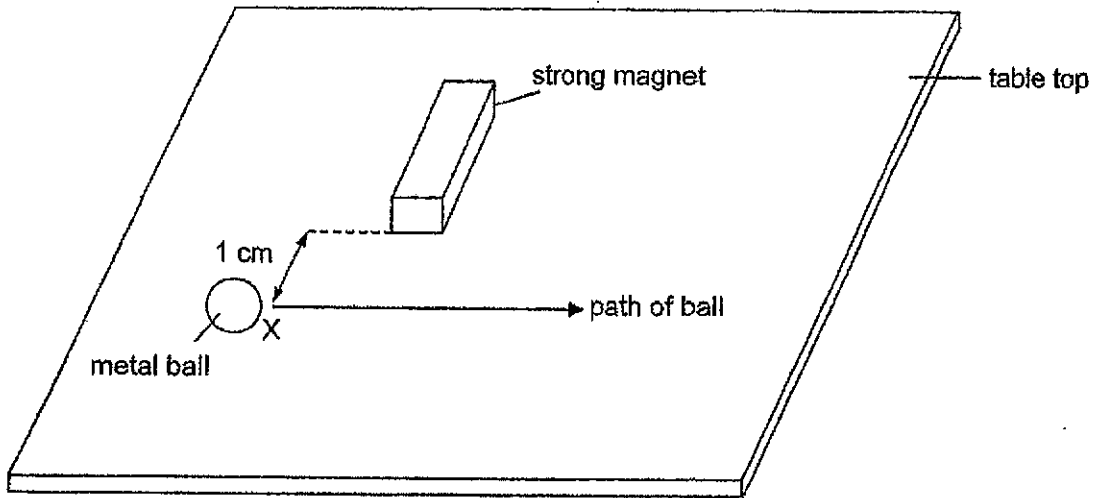

(a) Explain why the metal ball moved past the magnet in a straight line. [1]

(b) He next rolled an iron ball from X in the same way.

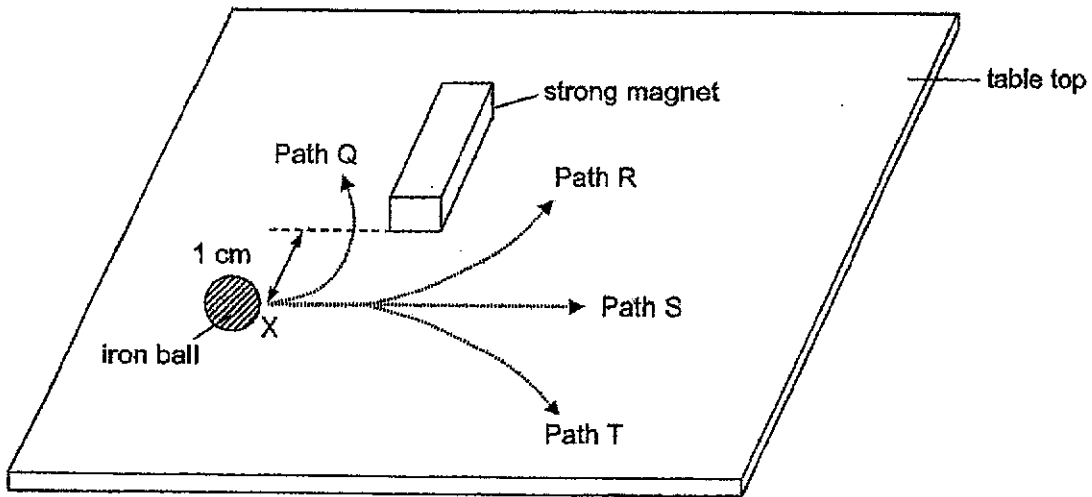

Which path of the iron ball, Q, R, S or T, is most likely? Explain your answer. [2]

(Go on to the next page)

SCORE	/
	3

- 37 Aisha tied a mass to an electric toy train as shown in Diagram 1. The train moved slowly from A to B.

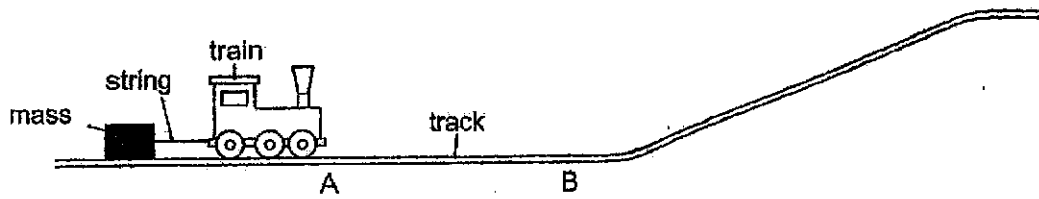

Diagram 1

Next, Aisha linked a wagon to the train as shown in Diagram 2. When she placed the same mass on the wagon, the train moved faster from A to B.

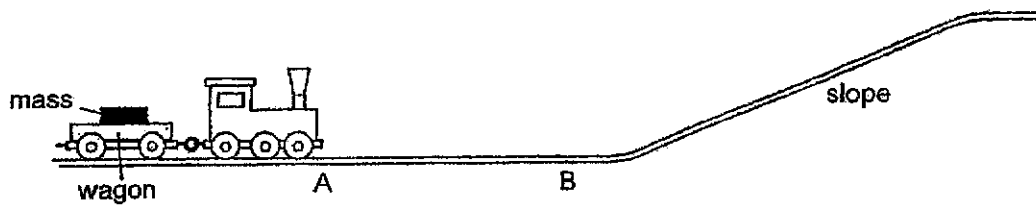

Diagram 2

- (a) Give a reason why the train moved faster when pulling the mass on the wagon. [1]

- (b) The train moved from A to B easily but moved up the slope slowly. Explain why the train moved up the slope slowly. [1]

The train and wagon were linked by plastic rings as shown in Diagram 3.

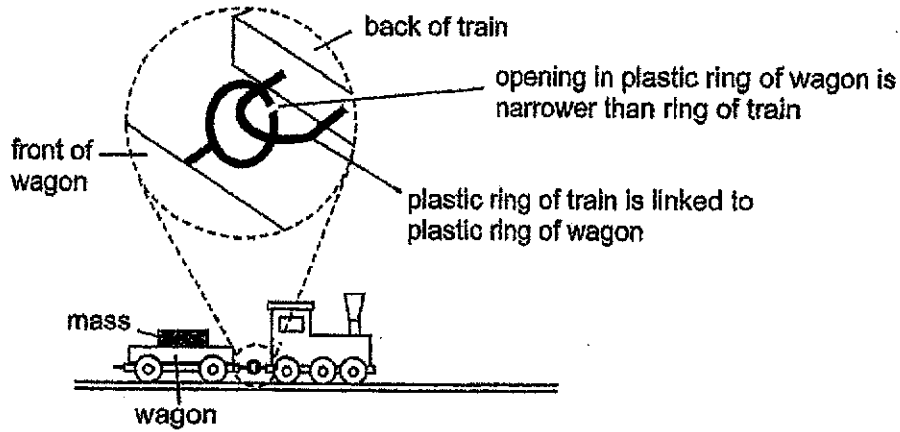

Diagram 3

When the wagon was on the slope, it broke loose from the train and rolled downwards as shown in Diagram 4. The plastic rings used for linking the wagon to the train were not broken.

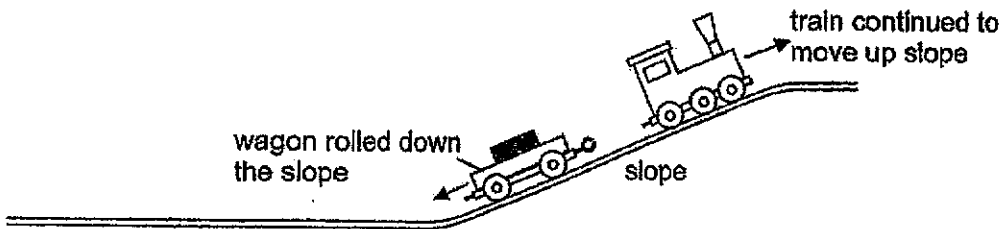

Diagram 4

(c) Explain why the wagon broke loose from the train on the slope without breaking the plastic rings. [2]

(Go on to the next page)

SCORE	4
-------	---

- 38 Ahmad set up an experiment in a room as shown. There was no wind. He released the wooden strip with plasticine at A gently. The plasticine made one complete swing when it moved from A to B and back to A.

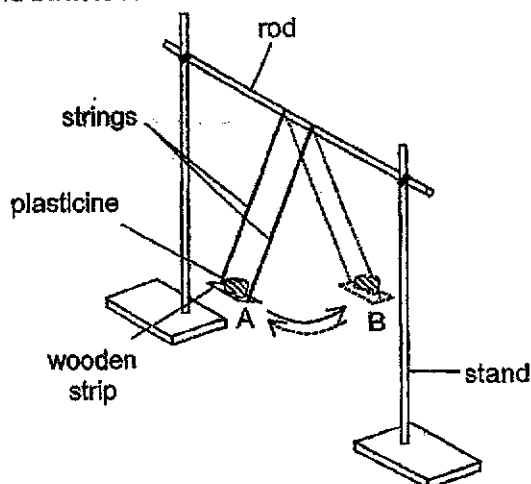

He wanted to investigate how the mass of plasticine affects the time taken for ten complete swings. His results are as shown.

mass of plasticine (g)	time for ten complete swings (s)
10	15.0
15	14.8
20	15.2
25	14.9

- (a) State two variables he needed to keep constant for the experiment. [2]

- (b) Based on his results above, state how the mass of plasticine affects the time for ten complete swings. [1]

- (c) Suggest one improvement to the experiment to obtain more accurate results. [1]

SCORE	4
-------	---

- 39 Peter built a door lock as shown. When he closed the switch, the iron bolt moved to the right, away from the catch and the door was unlocked.

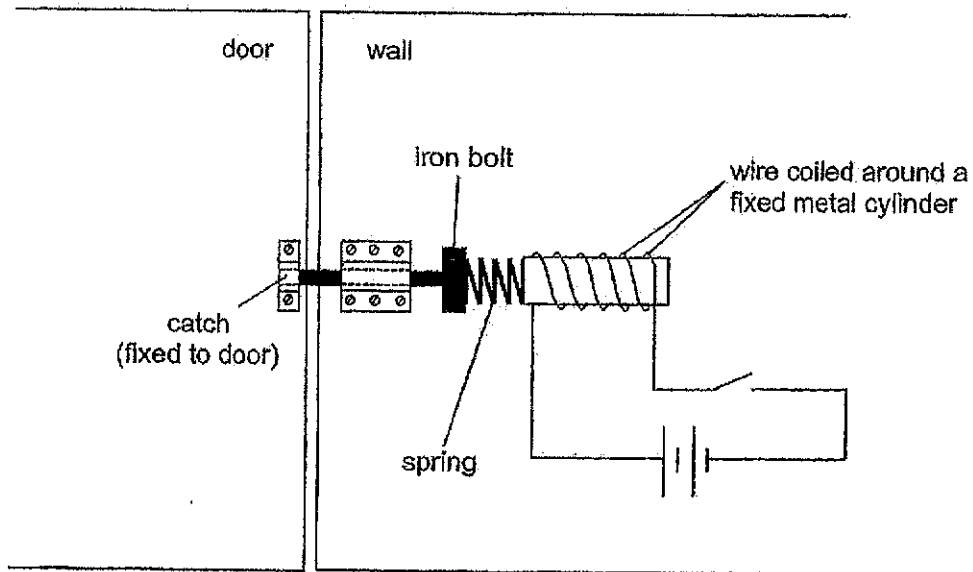

- (a) State why copper, a type of metal, is used to make wires. [1]

- (b) Explain how the door was unlocked when Peter closed the switch. [2]

- (c) When Peter opened the switch again, he found that the bolt did not go deep enough into the catch to lock the door properly.

Without changing the iron bolt, suggest changes to his set-up so that he can lock and unlock the door properly. Explain your answer. [2]

(Go on to the next page)

SCORE	5
-------	---

- 40 John placed a pack of brown sausages wrapped in clear plastic from the freezer onto a table. After a short time, a thin layer of white solid was formed on the surface of the plastic wrapping.

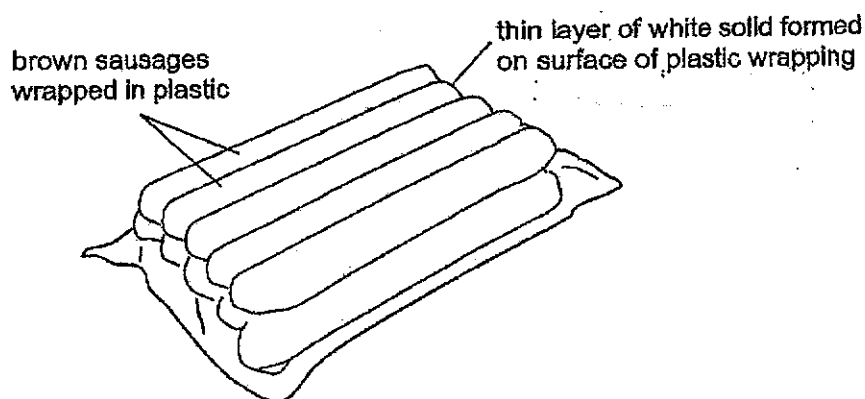

- (a) Explain how the white solid was formed. [2]

- (b) The white solid cannot be seen after a while. Explain why. [1]

SCORE	3
-------	---

End of Paper

Copyright Acknowledgements:

The Singapore Examinations and Assessment Board has made every effort to trace copyright holders, but if we have inadvertently overlooked any, we will be pleased to make the necessary arrangements at the first opportunity.

SCHOOL : TAO NAN PRIMARY SCHOOL
LEVEL : PRIMARY
SUBJECT : SCIENCE
TERM : 2024 SA1

Q 1	Q2	Q3	Q4	Q5	Q6	Q7	Q8	Q9	Q10
1	4	1	3	1	2	4	3	3	2
Q 11	Q12	Q13	Q14	Q15	Q16	Q17	Q18	Q19	Q20
4	4	4	2	2	4	3	3	1	3
Q 21	Q22	Q23	Q24	Q25	Q26	Q27	Q28		
2	4	3	4	3	4	3	4		

Q29)	<p>a) Circulatory system. Transport blood which carries oxygen, water on digested food to all parts of the body.</p> <p>b) Heart</p> <p>c) Blood vessels and blood.</p>
Q30)	<p>a) E: Wind F: Explosive action</p> <p>b) F does not need to depend on other factors to disperse its seeds.</p> <p>c) Turn the fan speed higher or move E closer to the fan.</p>
Q31)	<p>a) P: stem Q: Leaves</p> <p>b) H represents water and mineral salts water and mineral salts are taken in by the roots and transported by the water carrying tubes up the stem and to other parts of the plant.</p>
Q32)	<p>a) Mosquito larva breath through a breathing tube which if block by oil will not allow the mosquito larva to get oxygen and therefore leading to death.</p> <p>b) i)The smell of the shirt causes an increase in the attraction on of mosquito A.</p>

	<p>ii)The mosquito will be more visible on a white shirt compared to a black shirt which makes counting the mosquito more accurate.</p> <p>iii)Joel could place the smell away from people thus at tracking more mosquito to fly away from people.</p>
Q33)	<p>a)As bees visit plants to collect nectar, pollen grains catches on their bodies and transfer them from the flower of one plant to the flower of another plants through the stigma. Pollination will take place and thus the plant will reproduce.</p> <p>b)The bees need to trave the same distance to both container.</p> <p>c)On Day 1, there was no difference in the number of times the bees visit both containers. On day 5 and Day 10, the number of times the bees visited the Container S increased while the number of times the bees visited the Container R decreased.</p>
Q34)	<p>a)As light could pass through Container A, some of the tiny organisms used the light to photosynthesize which increased the amount of oxygen. Light could not pass through Container B and oxygen was used up by the tiny organisms which caused it to decreased.</p> <p>b)When he opened the lid, some oxygen could escape from the container.</p>
Q35)	<p>a) Boiling is a process where the water reached 100°C the heights it can go is turning from the liquid state to the gaseous state.</p> <p>b) She could place is an insulator to cut down heat loss. She could also pour boiling water into the pot.</p>
Q36)	<p>a) Metal is not a magnetic material thus not being attracted by the metal.</p> <p>b) Path R. Magnet is the strongest at its poles while the iron ball which is a magnetic material roll past the pole, will be attracted to therefore going on path R.</p>
Q37)	<p>a) The wheels on the wagon reduces the friction the wheels and the tracks.</p>

	<p>b)The train has to go against gravity.</p> <p>c)As the plastic is flexible the weight of the wagon pull the opening of the plastic ring wider.</p>
Q38)	<p>a)Ahmad must release the wooden strip from the same height as A gently. The length of the string connected the wooden strip and the rod must be constant.</p> <p>b)As there is no trend in the results the mass of the plasticine does not effects the time take for ten complete swings.</p> <p>c)Recond the times for more complete swings.</p>
Q39)	<p>a) Copper is a good conductor of electricity thus it is a good metal to make wires.</p> <p>b) When Peter closed the switch, electricity flows through and the metal cylinder becomes and electromagnet which attracts the iron bolt and causes it to move to the right, away from the catch. So, the door in unlocked.</p> <p>c) Change the spring to a stiffer spring which will have more elastic spring force. When the iron bolt is released from the electromagnet, it will force the iron bolt to move to the left, caused the iron bolt spring deeper into the catch.</p>
Q40)	<p>a)The water droplets will be heat to the sausages and freezer solid the white solid.</p> <p>b)The white solid gain heat from the surroundings and melt into water droplets.</p>

