



**NAN HUA PRIMARY SCHOOL
SEMESTRAL ASSESSMENT 1 – 2018
PRIMARY 6**

SCIENCE

BOOKLET A

28 Multiple Choice Questions (56 marks)

Total Time for Booklets A and B : 1 hour 45 minutes

INSTRUCTIONS TO CANDIDATES

1. Write your name and index number in the space provided.
2. Do not turn over the page until you are told to do so.
3. Follow all instructions carefully.
4. Answer all questions.
5. Shade your answers in the Optical Answer Sheet (OAS) provided.

Marks Obtained

Booklet A		/ 56
Booklet B		/ 44
Total		/ 100

Name: _____ () **Class:** P 6 _____

Date : 9 May 2018

Parent's Signature: _____

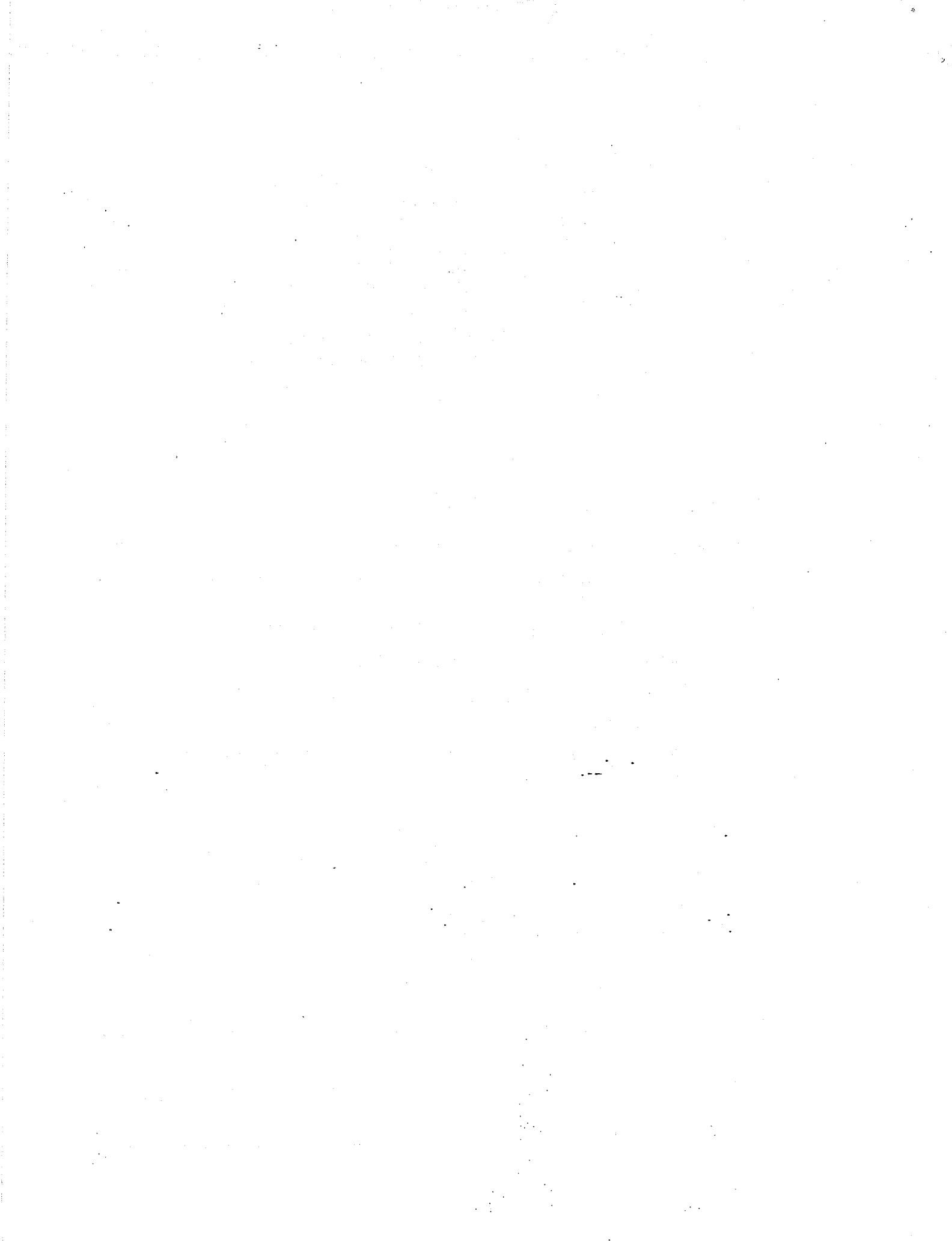

Section A: (28 × 2 marks = 56 marks)

For each question from 1 to 28, four options are given. One of them is the correct answer. Make your choice (1, 2, 3 or 4). Shade the correct oval (1, 2, 3 or 4) on the Optical Answer Sheet.

1. The diagram below shows a small ring of bark being removed from a plant. A few days later, swelling was seen above the ring.

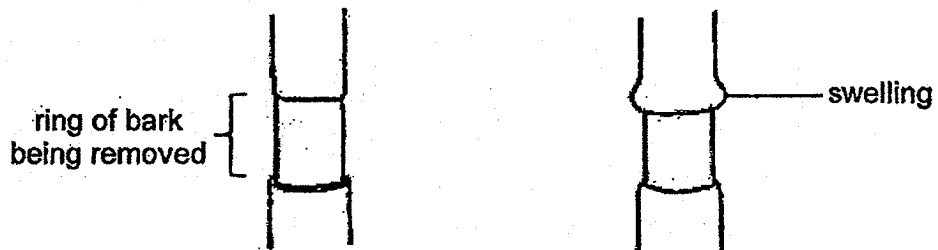

Which of the following statements is definitely true?

- (1) The food carrying tube is cut.
- (2) The water carrying tube is cut.
- (3) Chlorophyll is trapped at the swelling.
- (4) Both food and water carrying tubes are cut.

2. The table below shows the function of some of the body systems.

Body System	Function
A	One part of this system is the longest so that the substances will take the longest time to pass through it to be broken down.
B	One part of this system has hairs that prevent dust particles from entering the body.
C	Every part of this system needs to work closely with the muscles to provide movement.

Which body systems could A, B and C represent?

	A	B	C
(1)	Digestive system	Respiratory system	Circulatory system
(2)	Digestive system	Respiratory system	Skeletal system
(3)	Respiratory system	Digestive system	Skeletal system
(4)	Circulatory system	Respiratory system	Digestive system

3. A group of pupils is going on a field trip at Bukit Timah Nature Reserve. They need to study the physical conditions of the environment and record their findings.

Which of the following items should they take with them?

- A Datalogger
- B Digital camera
- C Bunsen burner
- D Magnifying glass

- (1) B and C only
- (2) C and D only
- (3) A, B and D only
- (4) A, B, C and D

4. The following organisms were found at a particular habitat.

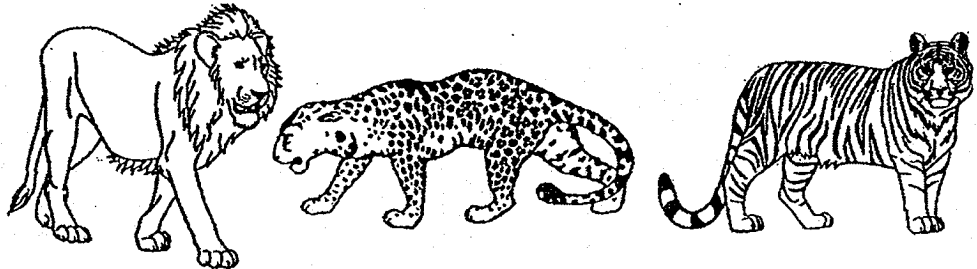

Which of the following living factors attracted all these organisms to the same habitat?

- A Presence of air
- B Presence of prey
- C Presence of water
- D Presence of diseases

- (1) B only
- (2) A and C only
- (3) B and D only
- (4) A, B and C

5. A garden was infested with bug X. The gardener carried out an experiment. He sprayed similar amount of pesticide A on two similar potted plants in the garden with 100 bug X in each pot.

The table below shows the number of bug X that died in each week.

	Number of bugs that died	
	Pot 1	Pot 2
Week 1	15	16
Week 2	14	12
Week 3	13	10
Week 4	11	10

What can be concluded from this experiment?

- (1) The pesticide caused the bug to reproduce.
- (2) The pesticide is effective in killing the plant.
- (3) The pesticide does not have any effect on the plant.
- (4) The pesticide slowly loses its effectiveness in killing the bug.

6. Study the diagram below.

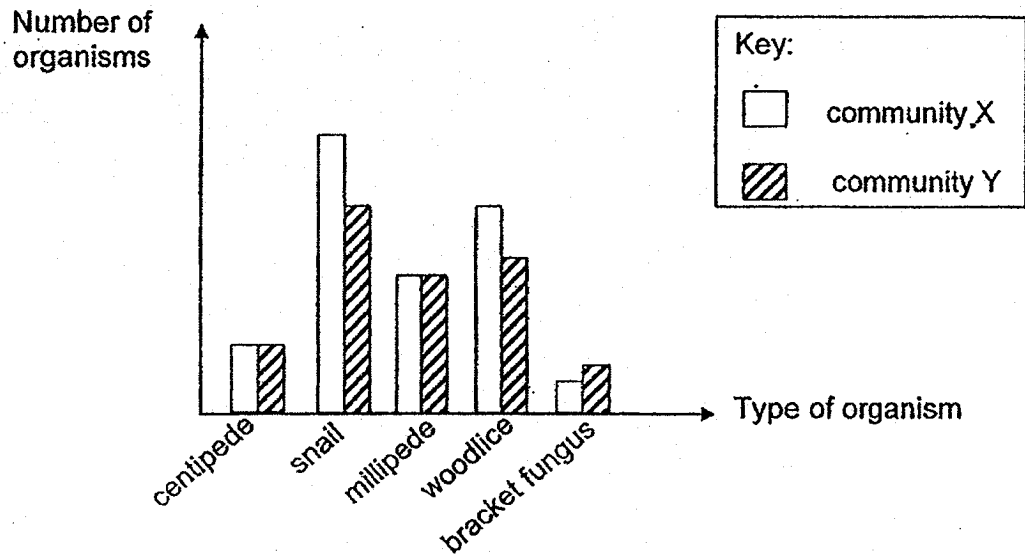

Which of the following statements is/are true?

- A There are four populations in community X and Y.
- B The organisms in each of the community is dependent on one another.
- C Community X is most likely a seashore community while community Y is a leaf litter community.

- (1) B only
- (2) C only
- (3) A and B only
- (4) A and C only

7. Alan made a study on two types of habitats and recorded his observations in the table below. A tick (✓) indicates that the observation is seen.

Observations	Habitat A	Habitat B
Pesticides is used on plants		✓
Butterflies are flying in this area		✓
Dragonfly nymphs are found at the bottom of water	✓	
Floating plants are found at the surface of water	✓	

Which of the following do habitats A and B represent?

	Habitat A	Habitat B
(1)	Pond	Garden
(2)	Swamp	Field
(3)	Pond	Rotting log
(4)	Seaside	Leaf litter

8. The diagrams below show the stomata and lungs.

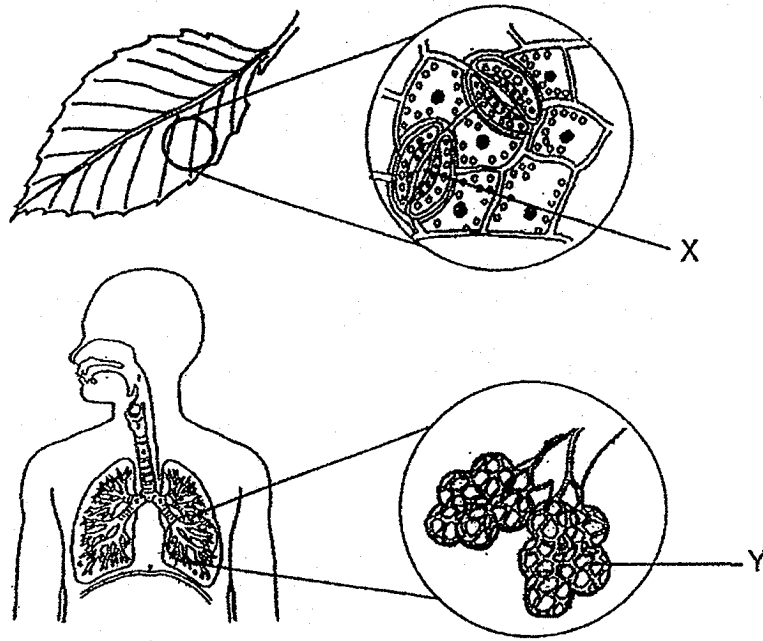

What is the similarity between structure X and Y?

- (1) X and Y allow air to be stored.
- (2) X and Y allow food to be stored.
- (3) X and Y allow water to be taken in.
- (4) X and Y allow gaseous exchange to take place.

9. The diagram below shows the different systems in our body working together. The arrows show the movement of different substances.

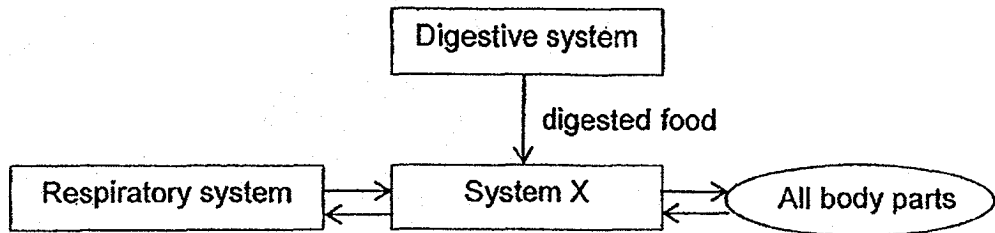

Which of the following statements is/are true about system X?

- A System X contains a heart.
- B System X carries digested food only.
- C System X carries oxygen and digested food only.

- (1) A only
- (2) C only
- (3) A and B only
- (4) A, B and C

10. The diagram below shows part of a plant covered with a thick black bag for a day.

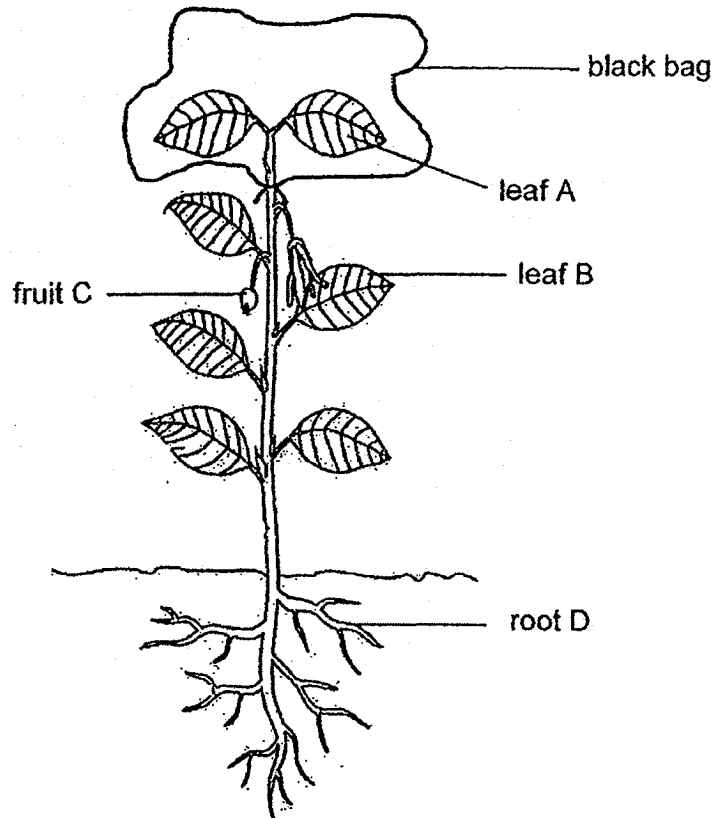

The cells taken from leaf A, leaf B, fruit C and root D are examined. Which of the following correctly shows the parts of the cell present in leaf A, leaf B, fruit C and root D?

	Cell part Plant part	cell wall	cytoplasm	chloroplast	cell membrane
(1)	leaf A	Present	Present	Absent	Present
(2)	leaf B	Present	Absent	Present	Present
(3)	fruit C	Present	Present	Absent	Present
(4)	root D	Absent	Present	Absent	Present

11. The diagrams below show the development of part X in a plant.

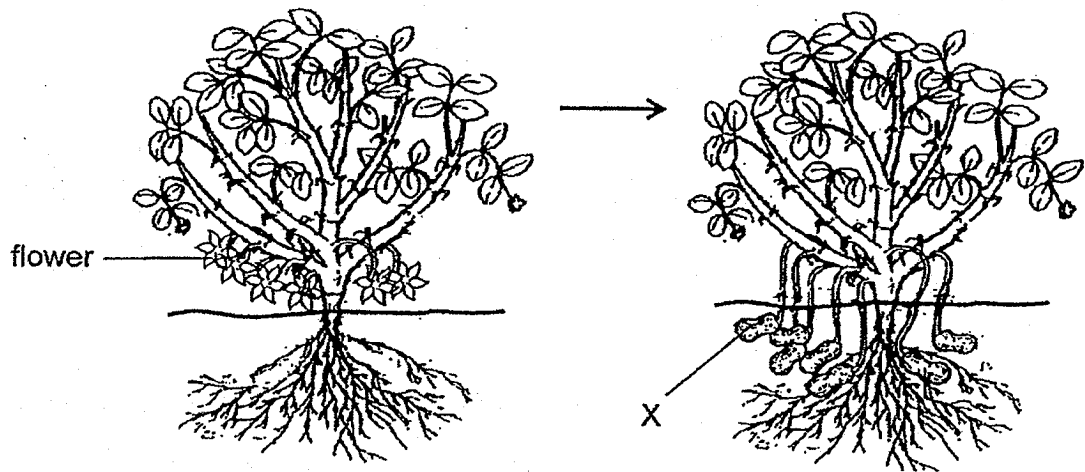

What processes have taken place for the development of X?

- (1) Pollination and fertilisation
- (2) Pollination and germination
- (3) Fertilisation and germination
- (4) Fertilisation and seed dispersal

12. Study the diagram below carefully.

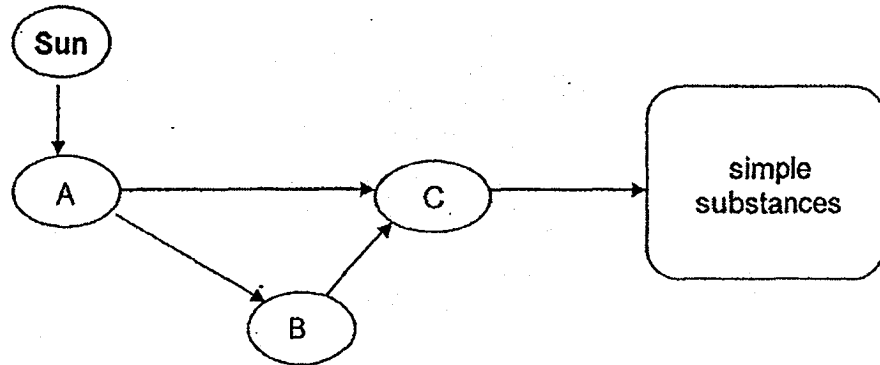

Which of the following statements about organisms A, B and C are true?

- A Organism A obtains light energy from the Sun.
- B Organisms A and B get energy directly from the Sun.
- C Organism C helps to break down dead organisms A and B into simple substances.

- (1) A and B only
- (2) A and C only
- (3) B and C only
- (4) A, B and C

13. The diagram below shows the pond community.

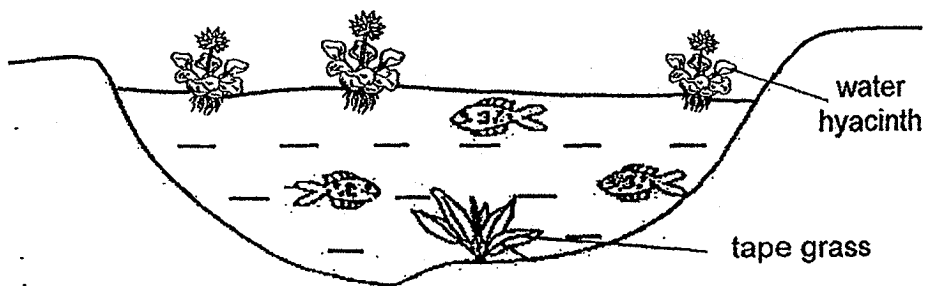

Which of the following is/are possible cause(s) for the decrease in the number of fish when all the water hyacinths are wiped out?

- A There is a decrease in the places for the fish to lay eggs.
- B There are no water hyacinths to provide oxygen for the fish.
- C The increase in tape grass increases the shelter for the fish to hide from its predator.

- (1) A only
- (2) B only
- (3) A and C only
- (4) A, B and C

14. The diagram below shows a concept map.

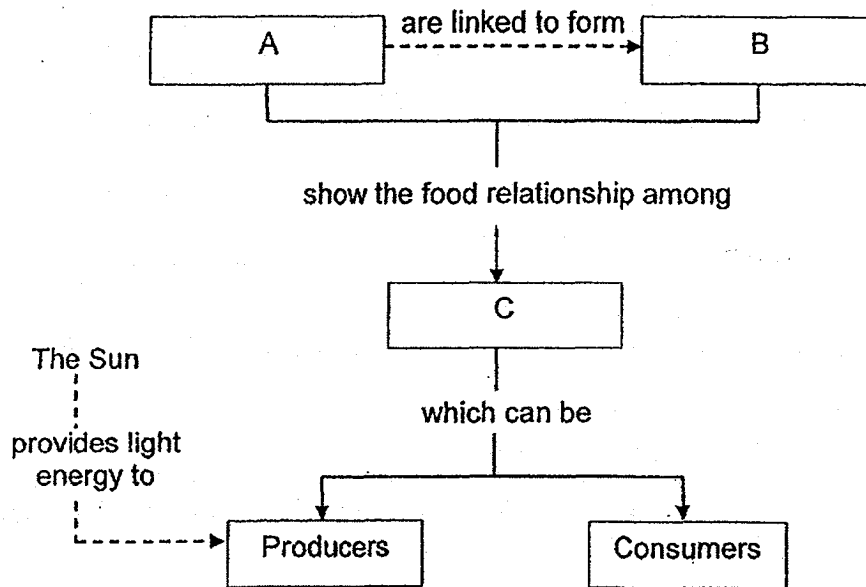

Which one of the following correctly represents A, B and C in the concept map?

	A	B	C
(1)	Food chains	Food webs	Organisms
(2)	Food chains	Food webs	Decomposers
(3)	Food webs	Food chains	Organisms
(4)	Food webs	Decomposers	Food chains

15. Study the food web shown below carefully.

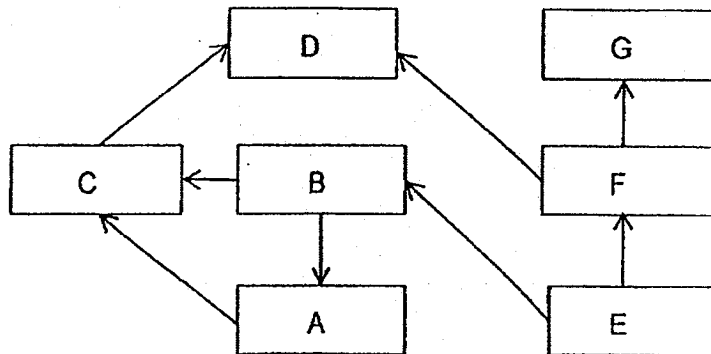

Which of the following statements about the food web is/are definitely correct?

- A Organisms D and G are predators.
- B Organisms A, B, C and F are both a prey and predator.
- C All the organisms in the food web are definitely food consumers.

- (1) A only
- (2) B only
- (3) B and C only
- (4) A, B and C

16. Ethan threw a ball upwards.



Which of the following statements is/are true?

- A The gravitational force of the Earth causes the ball to change its mass.
- B The gravitational force of the Earth causes the ball to change its direction of movement.
- C When the ball is moving upwards, the gravitational force of the Earth does not act on it.
- D The gravitational force acting on the ball is the highest when it reaches the highest point.

- (1) B only
- (2) D only
- (3) A and B only
- (4) C and D only

17. Study the flow chart below.

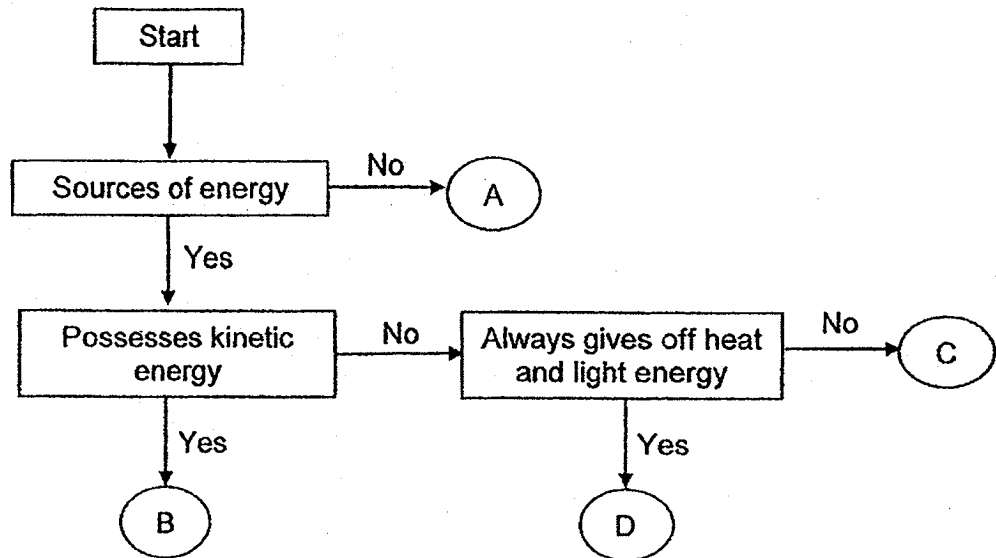

What could B and D represent?

	B	D
(1)	Bouncing ball	Coal
(2)	Running water	Sun
(3)	Rolling ball	Oil
(4)	Wind	Moon

18. A block of melting ice is placed in a box as shown in the diagram below.

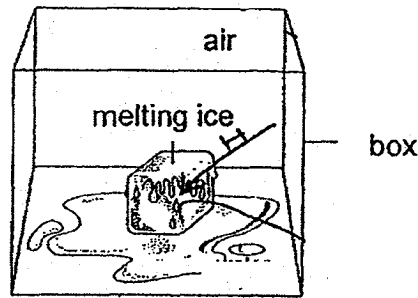

What will happen to the temperature of the air and melting ice in the box during the process of melting?

Temperature of	
Air	Melting ice
(1) Remains the same	Increases
(2) Increases	Remains the same
(3) Decreases	Remains the same
(4) Decreases	Decreases

19. A group of pupils pulled object W across surface X as shown in the diagram below.

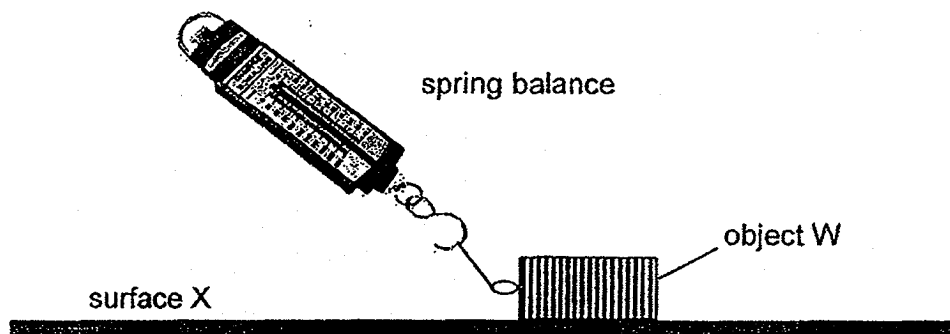

The group of pupils made the following statements:

- | | |
|---------|---|
| Aisha | More force was required to move object W when surface X was rougher. |
| Benny | The reading on the spring balance would be smaller when the bottom surface of object W was oiled. |
| Charles | A greater force was needed to move object W across the surface when a 50-g weight was put on top of object W. |
| Dane | When object W was placed vertically on surface X with a smaller surface area in contact with surface X, a smaller force was needed to move it across the surface. |

Which of the following pupils made the correct statements?

- (1) Aisha and Benny only
- (2) Charles and Dane only
- (3) Aisha, Benny and Charles only
- (4) All of the above pupils

20. Andy carried out the experiment below. He rolled the iron ball down the wooden plank and recorded the time taken for the ball to travel from A to M and from M to V before and after object X was placed below the wooden plank as shown below. The results were then recorded in the table below.

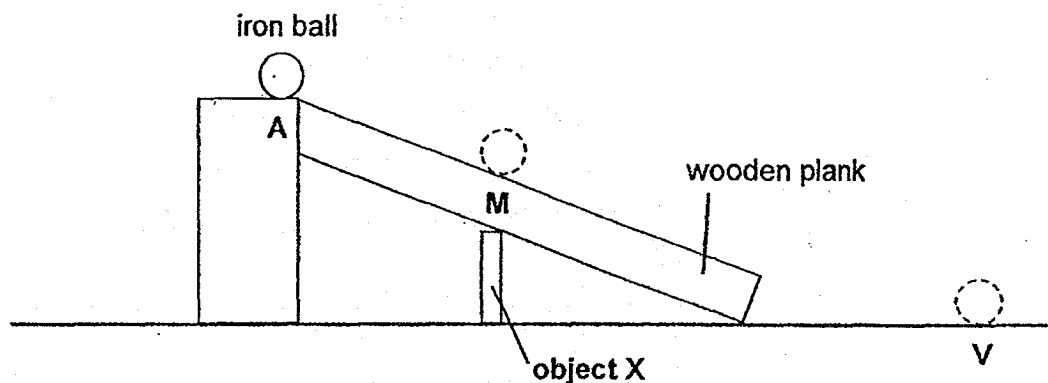

	Time taken to travel from A to M (seconds)	Time taken to travel from M to V (seconds)
Without object X	15	26
With object X	11	34

Which of the following is/are possible explanation(s) for the difference in the time taken for the ball to travel from one point to another point?

- A Object X was a magnetic material and attracted the ball.
- B Object X was a magnet and was attracting the ball, resulting in a longer travelling time from M to V.
- C Object X was a magnet and was repelling the ball, resulting in a shorter travelling time from A to M.
- D Object X was a magnet and was attracting the ball, resulting in a shorter travelling time from A to M.

- (1) A only
- (2) D only
- (3) B and C only
- (4) B and D only

21. Winston classified the energy that the following objects possess into 3 groups, Group 1, Group 2 and Group 3. There are 2 objects in each group.

A battery

A chocolate bar

Moving water in a river

Compressed spring in a toy

Rolling ball moving on flat ground

A stretched rubber band in a catapult

Which one of the following correctly represents the most likely headings for groups 1, 2 and 3?

	Group 1	Group 2	Group 3
(1)	Electrical Energy	Sound Energy	Kinetic energy
(2)	Chemical Potential Energy	Elastic Potential Energy	Heat Energy
(3)	Heat Energy	Elastic Potential Energy	Kinetic energy
(4)	Chemical Potential Energy	Elastic Potential Energy	Kinetic energy

22. Devi hooked a weight onto the lower end of a spring. She observed that the spring stretched as shown in the diagram below.

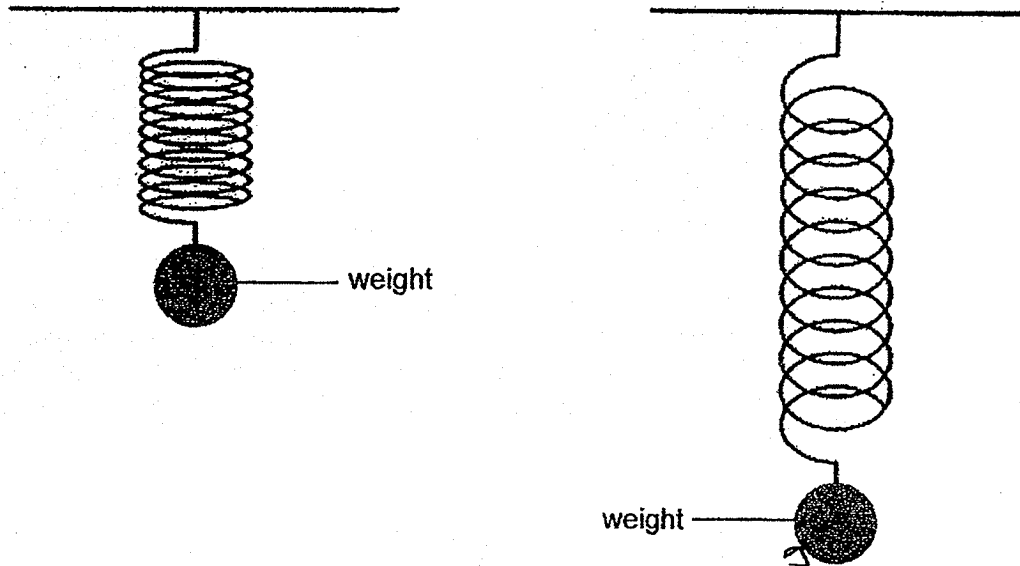

Based on her observation, which of the following statements is/are correct?

- A The spring stores more energy when it is stretched longer.
- B The weight stores more energy when the spring is stretched.
- C The energy from the spring is transferred to the ball when it is stretched.
- D The weight has less gravitational potential energy after the spring is stretched.

- (1) B only
- (2) C only
- (3) A and D only
- (4) A, B, C and D

23. Latimah has 3 sheets made of different materials as shown below.

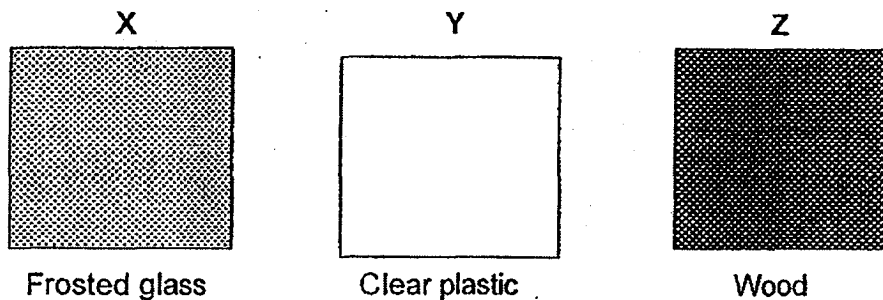

She first placed sheet X in between a light source and a datalogger. The datalogger is used to detect the amount of light that passes through the material. She then repeated this with sheets X and Y attached together and then finally, with all 3 sheets X, Y and Z attached together as shown below.

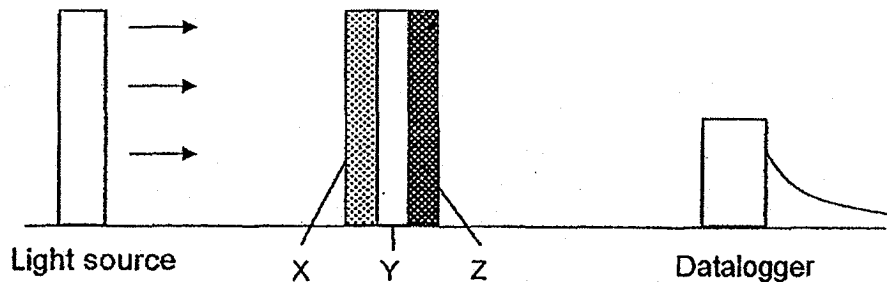

Which one of the following shows the most likely result of her experiment?

Amount of light detected by the datalogger (lux)			
	X only	X and Y attached	X, Y and Z attached
(1)	400	200	0
(2)	100	0	0
(3)	400	200	100
(4)	400	400	0

24. Two beakers were filled with the same amount of water from the tap. The water in both set-ups A and B were heated at the same time until they came to a boil.

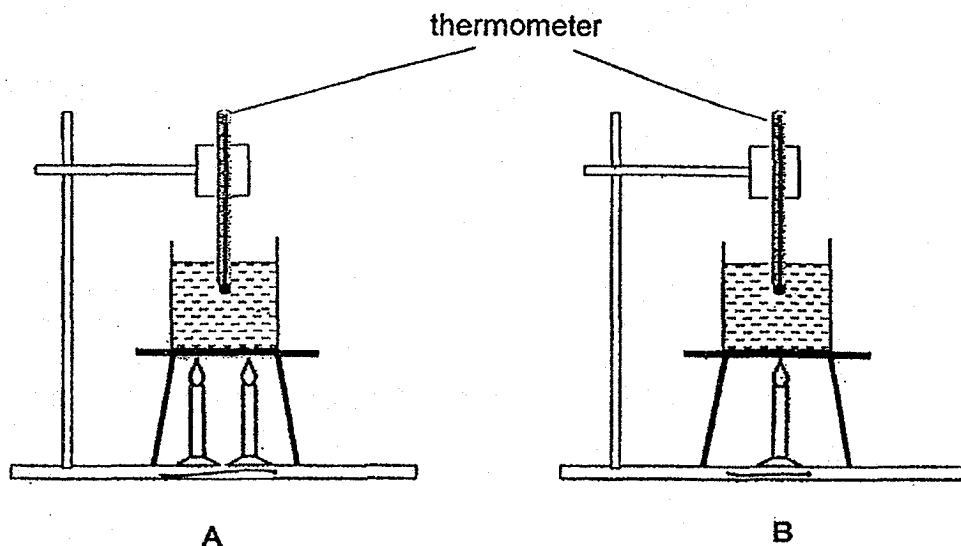

Which of the following statements about the set-ups above are true?

- A The water in set-up A will boil first.
- B The temperature of the water in set-up B rises slower than set-up A.
- C The amount of heat in the water in both set-ups is the same during heating.
- D The temperature of the water in set-up A is always higher than in set-up B.

- (1) A and B only
- (2) A and D only
- (3) B and C only
- (4) C and D only

25. Angela set up the circuits below using a bulb, 2 dry cells and objects P, Q and R.

Bulb does not light up

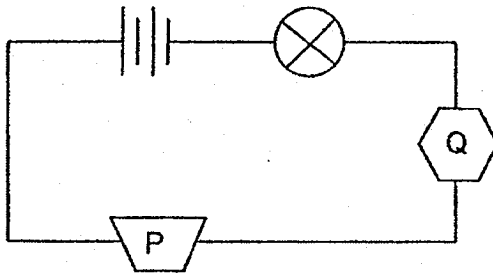

Bulb lights up

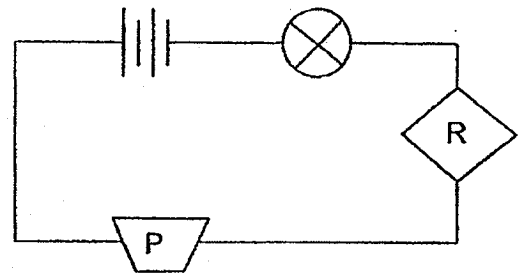

She used the objects P, Q and R, again to form the circuits below.

Circuit A

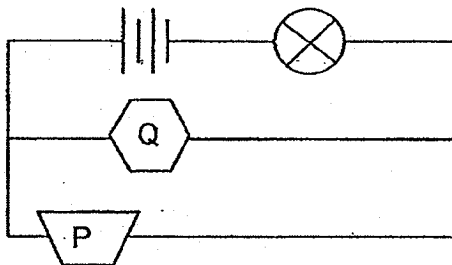

Circuit B

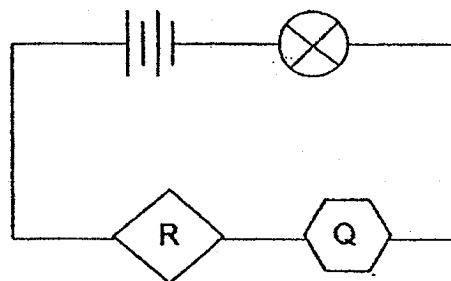
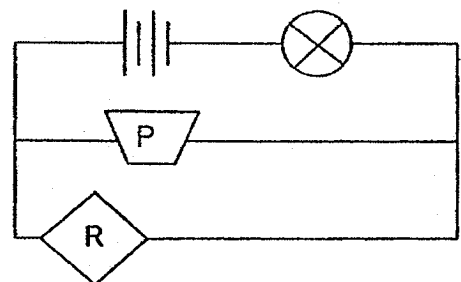

Circuit C

In which of the circuits, A, B and/or C, did the bulb light up?

- (1) Circuit B only
- (2) Circuit C only
- (3) Circuit A and B only
- (4) Circuit A and C only

26. Ali carried out an experiment to find out if 4 substances, honey, air, salt and cotton wool, can be compressed using the set-up shown below.

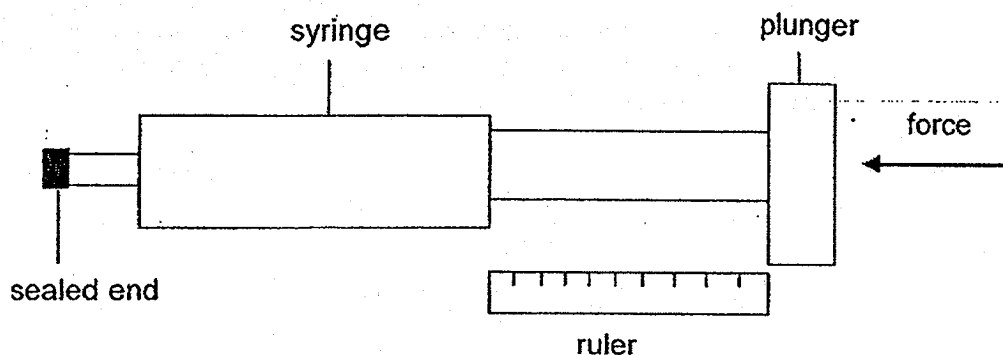

First, Ali filled the syringe completely with honey and pushed the plunger as hard as he could. He then measured the distance moved by the plunger and recorded it. He repeated the same steps for the other three substances.

Which set of data could Ali have recorded?

(1)

Distance moved by plunger	
Honey	0 cm
Air	2.5 cm
Salt	0.5 cm
Cotton wool	0 cm

(2)

Distance moved by plunger	
Honey	2.5 cm
Air	1 cm
Salt	0 cm
Cotton wool	1 cm

(3)

Distance moved by plunger	
Honey	1 cm
Air	2.5 cm
Salt	1 cm
Cotton wool	0 cm

(4)

Distance moved by plunger	
Honey	0 cm
Air	2.5 cm
Salt	0.2 cm
Cotton wool	1 cm

27. Which of the following statements about the water cycle is/are incorrect?

- A Water loses heat when it evaporates.
- B Clouds are made up of water vapour
- C Plants and animals also give out water vapour.
- D Water can change from one state to another when it gains or loses heat.

- (1) A only
- (2) A and B only
- (3) C and D only
- (4) B, C and D only

28. Chee Keong conducted an experiment to show that magnetic force can only pass through non-magnetic materials. He held a bar magnet above a paper clip which was tied to a weight by a string. The magnet attracted the paper clip without touching it. Then he placed four items, one at a time, between the magnet and the paper clip and observed if the paper clip dropped or remained where it was.

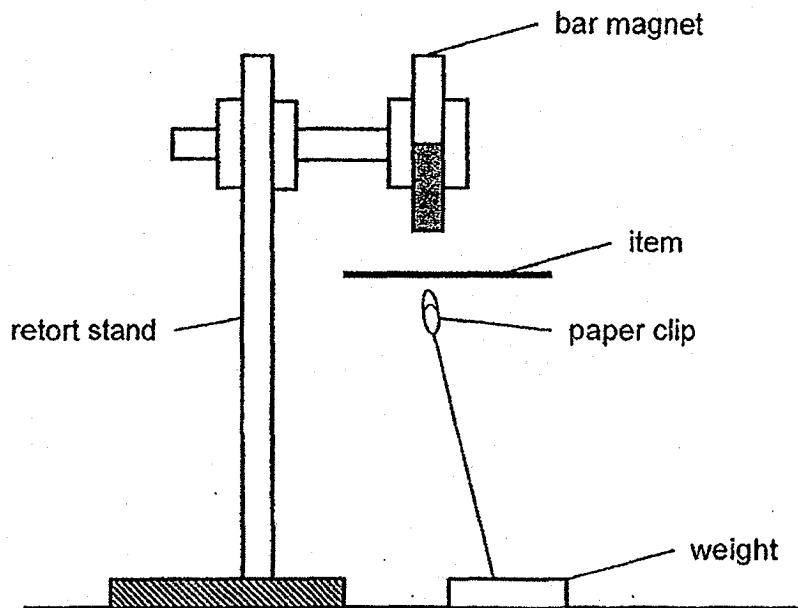

If the four items used in the experiment were a thin sheet of steel, a piece of aluminium foil, a piece of paper and a thin sheet of gold respectively, which one of the following observations would correctly show that magnetic force can only pass through a non-magnetic material?

	Steel	Aluminium foil	Paper	Gold
(1)	Remained	Dropped	Dropped	Remained
(2)	Remained	Remained	Dropped	Remained
(3)	Dropped	Dropped	Remained	Dropped
(4)	Dropped	Remained	Remained	Remained

End of Booklet A



NAN HUA PRIMARY SCHOOL
SEMESTRAL ASSESSMENT 1 – 2018
PRIMARY 6

SCIENCE

BOOKLET B

12 Open-ended questions (44 marks)

Total Time for Booklets A and B : 1 hour 45 minutes

INSTRUCTIONS TO CANDIDATES

1. Write your name and index number in the space provided.
2. Do not turn over the page until you are told to do so.
3. Follow all instructions carefully.
4. Answer all questions.
5. Write your answers in this booklet.

Marks Obtained

Section B

	/ 44
--	------

Name: _____ ()

Class: P 6 _____

Date : 9 May 2018

Parent's Signature: _____

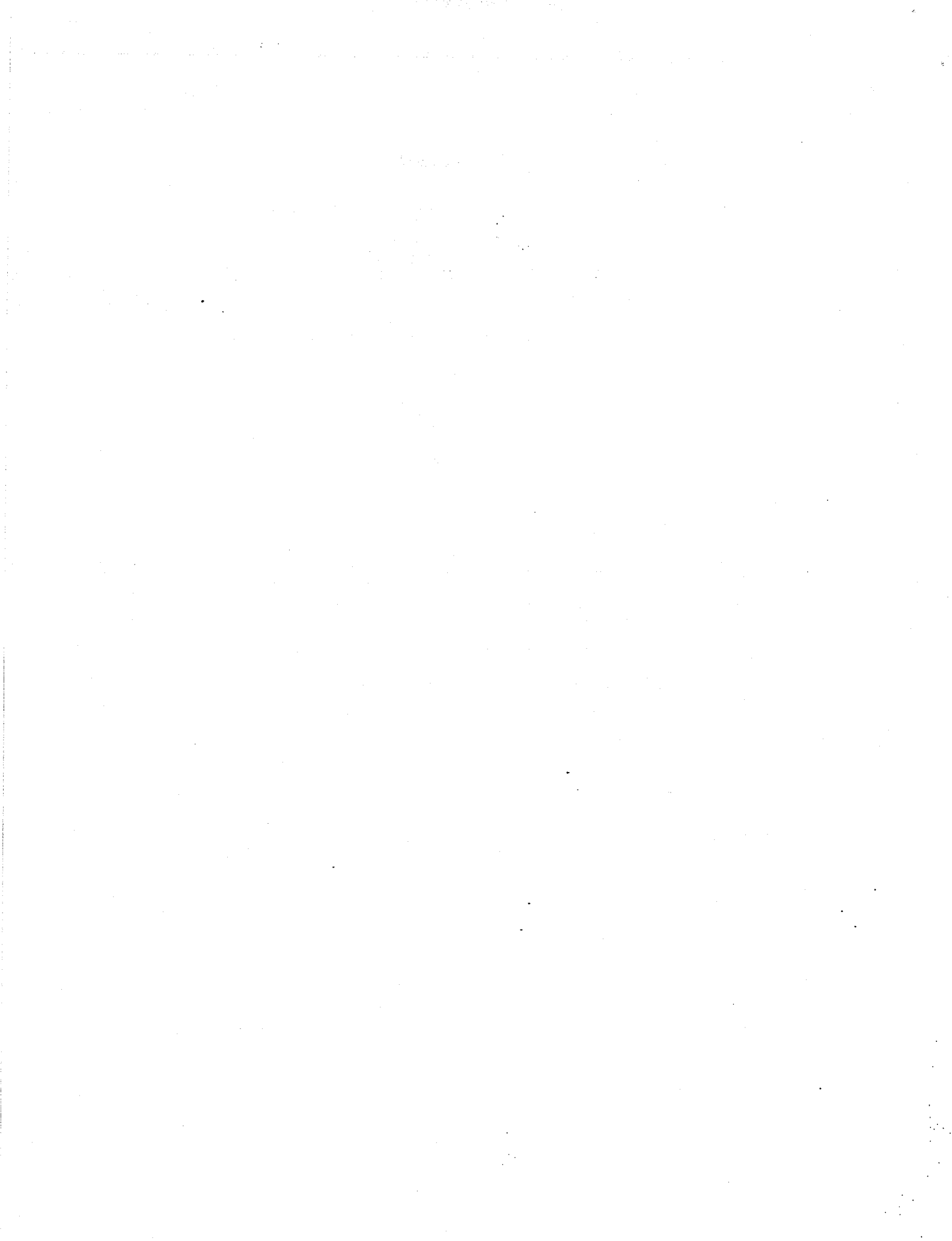

Section B: (44 marks)

Write your answers to question 29 to 40.

The number of marks available is shown in brackets [] at the end of each question or part question.

29. The diagram below shows an experimental set-up of the effect of light on insects in the leaf litter.

A piece of wire mesh was put at the base to hold the substances collected from the leaf litter. The substances were loosely packed into the funnel. A light source was put above the funnel for 12 hours.

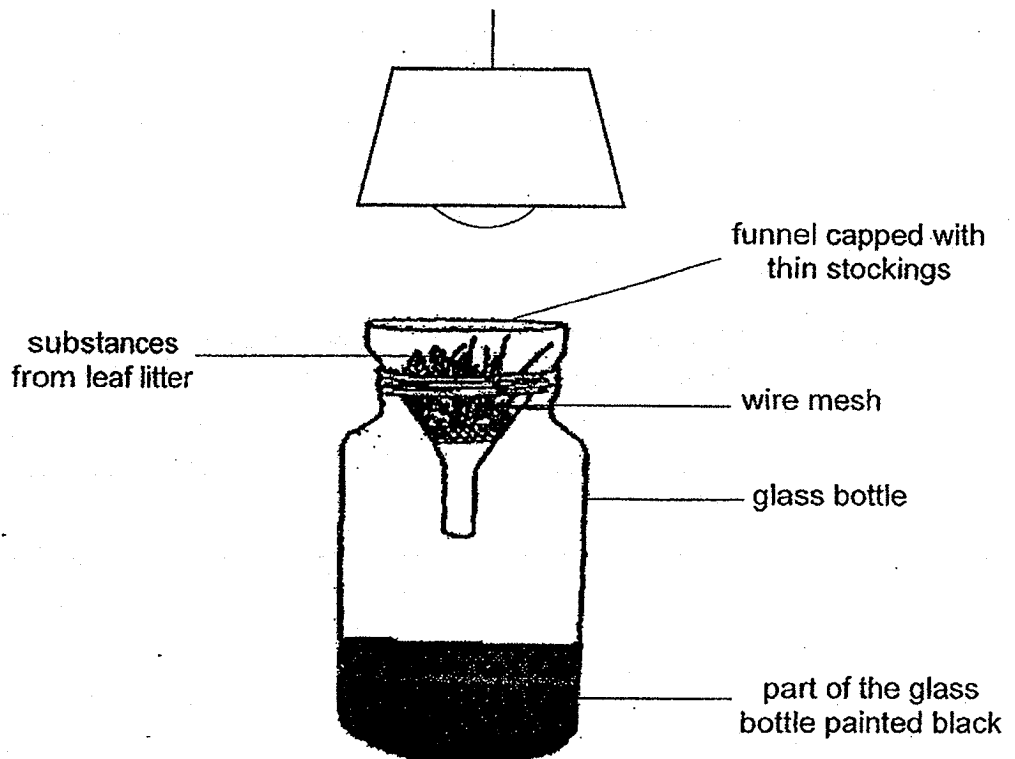

The number of insects that were collected at the bottom of the bottle was plotted in a graph as shown below.

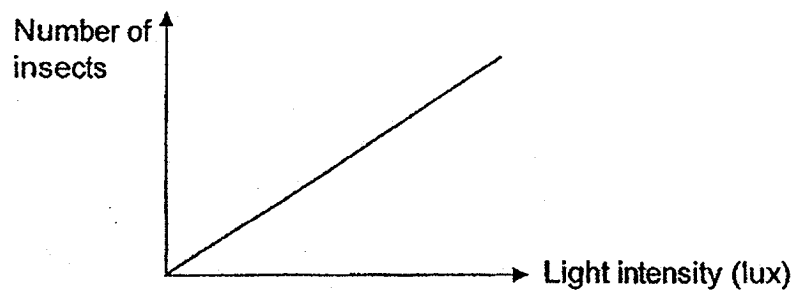

Go to the next page

- (a) State the relationship between the number of insects found at the bottom of the bottle and the light intensity on the leaf litter. [1]

- (b) Explain why more insects are found at the bottom of the bottle when the light intensity gets stronger. [1]

- (c) State a characteristic of living things that was displayed by the insects when light was shone on the funnel? [1]

Score	3
-------	---

30. Study the food web shown below.

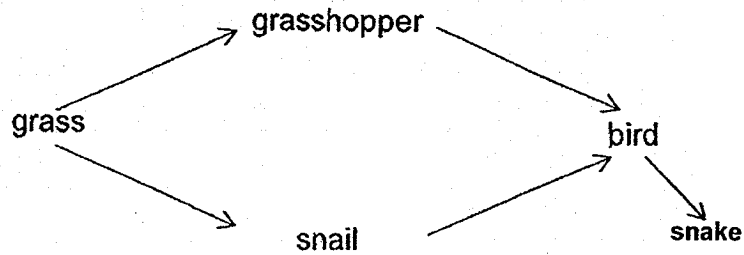

(a) Besides the garden habitat, name another habitat where the above organisms can be found. [1]

(b) How many food chains are there in the above food web? [1]

(c) Based on the information given in the food web above, to decrease the number of snail in the shortest time, how should the population size of two predators be changed? Give a reason for each of the change. [2]

Score	4
-------	---

31. Peter recorded his observations of fruit A, B and C in the table below.

Description of fruit	Observation of fruit A	Observation of fruit B	Observation of fruit C
Is edible	yes	yes	no
Has fibrous husk	no	yes	no
Is juicy and fleshy	yes	no	no
Is bright red only when ripe	yes	no	no
Has wing-like structure	no	no	yes

(a) What is the likely method of seed dispersal for fruit A? [1]

(b) Describe how being juicy and fleshy help the seeds to be dispersed further away from the parent plant. [1]

Go to the next page

The diagram below shows the seed dispersal pattern of one of the fruits.

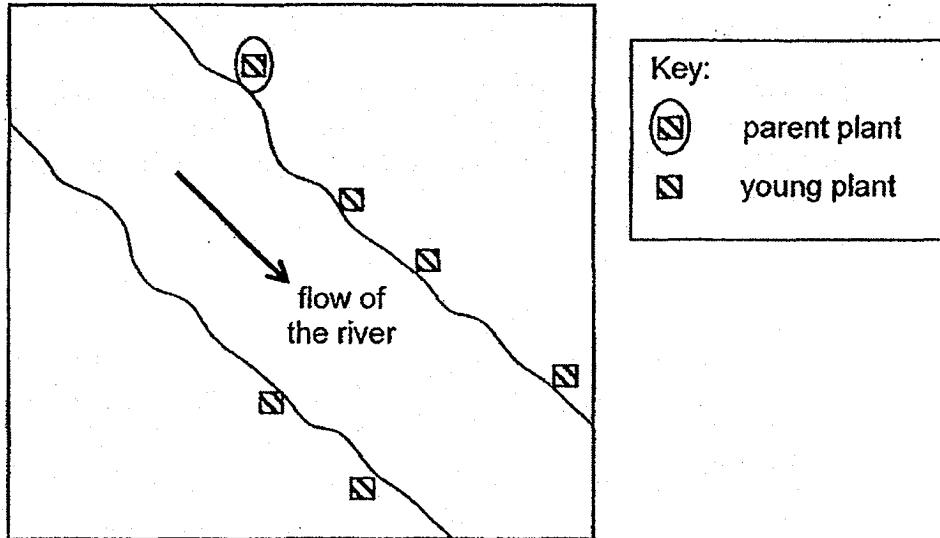

- (c) Based on the diagram, what is the likely method of seed dispersal of the fruit shown above? Give a reason for your answer. [1]

- (d) Based on the description, which fruit, B or C, has the seed dispersal pattern shown above? Explain your answer. [1]

Score	4
-------	---

32. Jane needed to identify two types of soil. One type was collected from the beach and the other from the mangrove swamp. The soil found in the beach is dry and has many air spaces. On the other hand, the soil found in the mangrove swamp is very wet with very little air spaces.

She set up an experiment as shown in the diagram below. She lined the funnel with filter paper and put equal amount of each type of soil on the filter paper. She measured the amount of water collected in the measuring cylinder after five minutes.

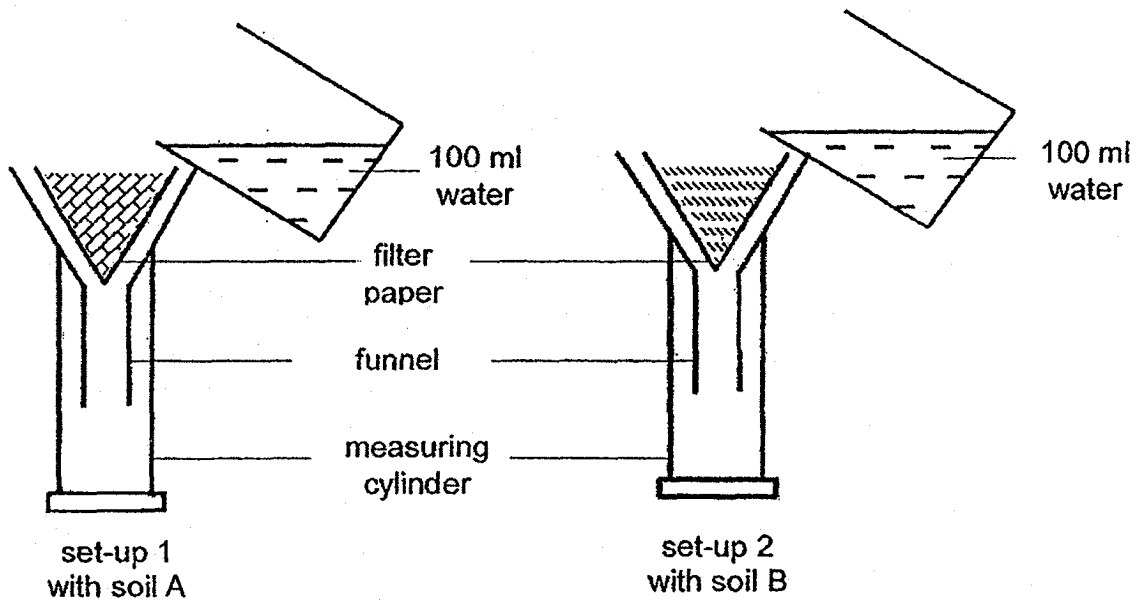

The results collected were recorded in a graph as shown below.

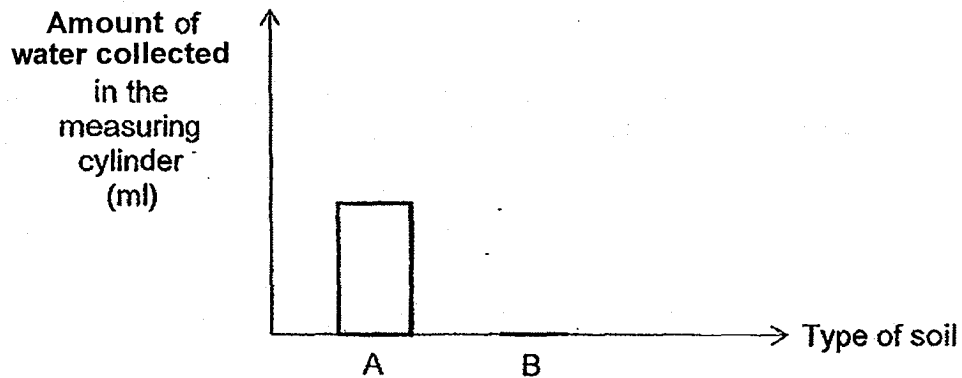

- (a) Explain clearly why the same amount of water is used in her experiment to ensure a fair test? [1]

(b) What should be done to get a reliable result?

[1]

(c) Based on the results, which soil, A or B, was collected from the mangrove swamp? Explain your answer.

[1]

Score	3
-------	---

33. The diagram below shows a food web.

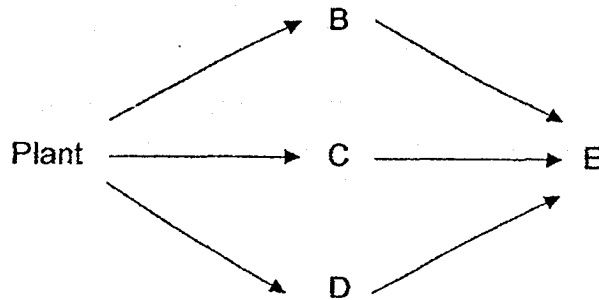

(a) Which organism(s) is/are predator(s)?

(b) In the food web, is there an organism that is both a prey and a predator? Explain your answer. [1]

(c) There cannot be too many organisms in a food chain. Explain why. [2]

Score	4
-------	---

34. The diagrams below show a spring before and after an iron block was hung on it.

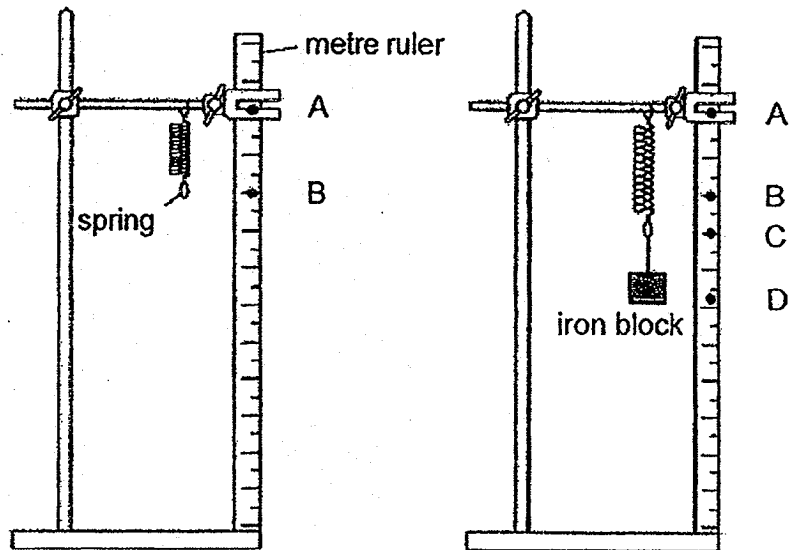

- (a) The extension of the spring is the distance between the positions labelled _____ and _____ on the metre ruler. [1]

- (b) Explain how the iron block was able to stretch the spring. [1]

- (c) The graph below shows the results when two different springs are stretched.

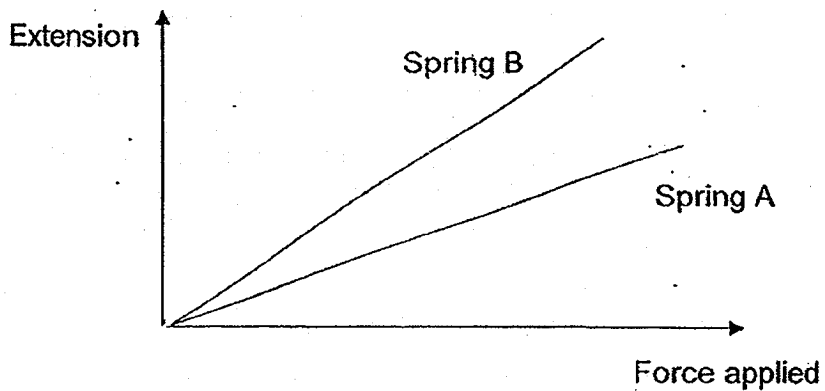

- Which spring, A or B, is stiffer? Give a reason for your answer. [1]

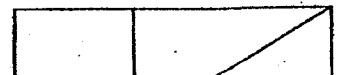

35. Sheldon uses a falling mass to split wooden logs. The 5-kg mass slides down the rod and hits the metal blade. The force exerted on the blade splits the log.

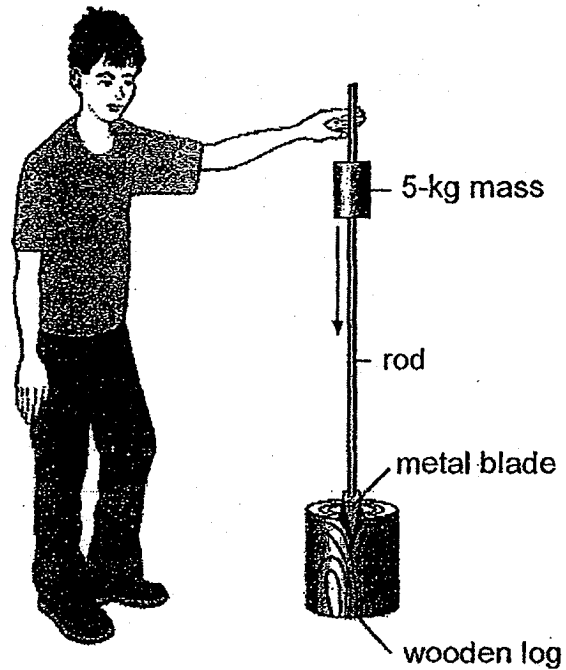

- (a) To lift the mass, Sheldon uses energy stored in his muscles. What is his source of energy? [1]
-
- (b) Not all the gravitational potential energy is converted to kinetic energy as the mass falls. Give a reason, in terms of energy, for this. [1]
-
- (c) Without changing the 5-kg mass, give two other ways Sheldon can increase the kinetic energy of the mass just before it hits the blade. [2]
-
-

Score	4
-------	---

36. Rajesh set up an experiment using the apparatus as shown below.

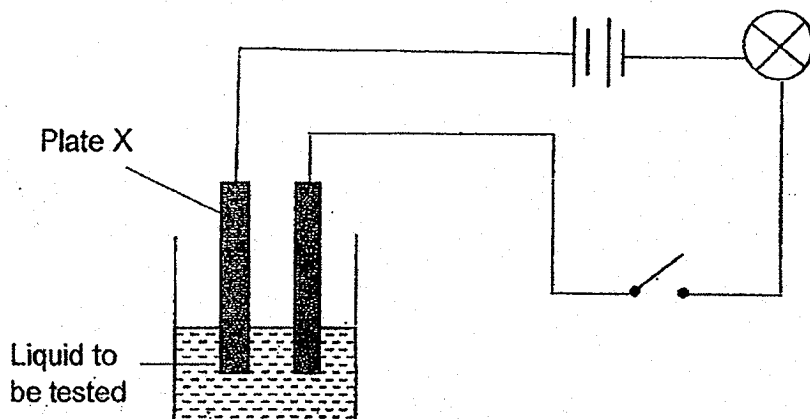

He tested 3 different types of liquids, one at a time, and recorded the brightness of the bulb in the table below.

Types of liquid	Brightness of bulb		
	Dim	Bright	Very bright
R		✓	
S	✓		
T (salt solution)			✓

(a) What does the results in the table tells us about a property of plate X? [1]

(b) Based on the results, what could Rajesh conclude about liquids R, S and T? [1]

(c) Explain why Rajesh would conclude that it is dangerous to swim in the sea when there is lightning. [1]

Score	3
-------	---

37. BASE jumpers jump from very high buildings and mountains for sport.

The diagram below shows a BASE jumper in flight.



- (a) In the diagram above, indicate two forces acting on the BASE jumper with an arrow each. Label the arrows clearly. [2]
- (b) To land safely on the ground, the BASE jumper opens a parachute. What effect does opening the parachute have on the falling BASE jumper? Explain why. [2]

Score	4
-------	---

38. A heater uses energy from a laptop computer to keep a drink hot.
The figure below shows a metal mug on the heater.
The laptop computer is operating on battery.

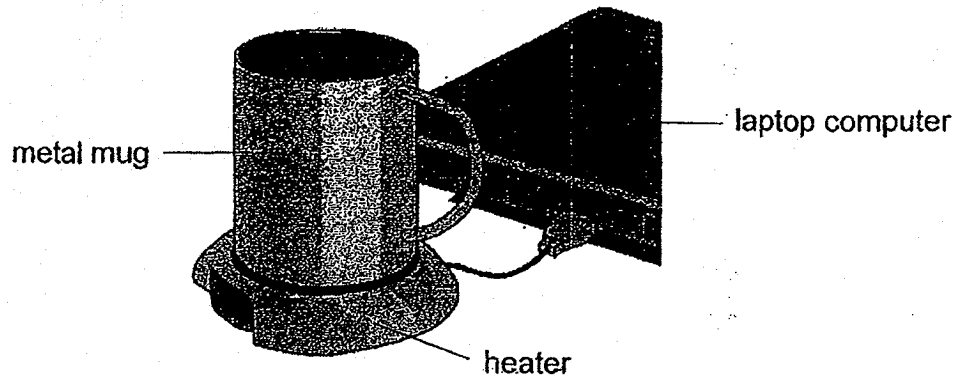

- (a) Write down the energy conversion when Penny connects the heater with the metal mug to her laptop computer which she was using to do her work. [2]

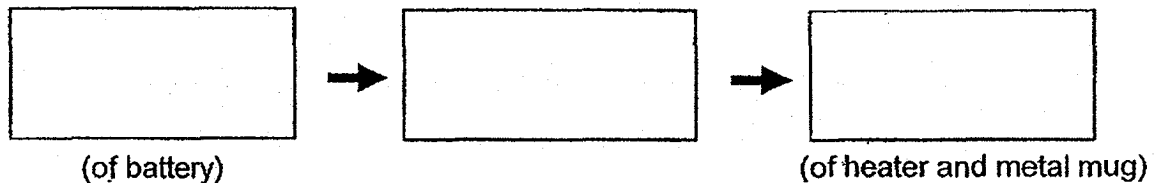

- (b) How would connecting the heater affect the amount of time the laptop computer would operate, before needing to be recharged? Give a reason for your answer. [1]

- (c) Explain why a metal mug is used in the above device instead of a plastic mug for warming up the drink faster. [2]

Score	5
-------	---

39. The diagram below shows a wet towel hung up to dry.

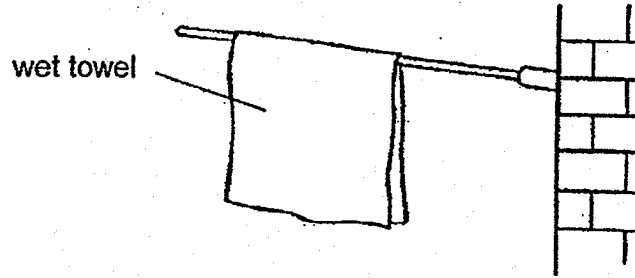

- (a) Describe and explain two changes that would happen to the water in the wet towel. [2]

- (b) Describe one change in the weather which would cause the wet towel to dry up faster. [1]

- (c) A runner in a hot country feels cooler if she pours water over her hair to keep it wet, even when the water is at the same temperature as the air around her. Explain why she feels cooler. [1]

Score	4
-------	---

40. Leonard tried to make a temporary magnet by stroking an iron nail with a steel rod in the direction shown below.

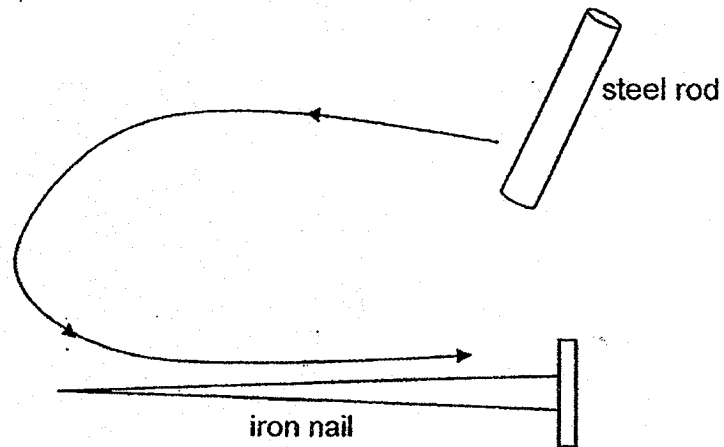

- (a) When some steel paper clips were brought near the iron nail, it did not attract any of the steel paper clips. What should Leonard do to make the iron nail attract the steel paper clips? [1]

- (b) After making the necessary change suggested in (a), the iron nail became a temporary magnet. What could Leonard do to make it a stronger one? [1]

Go to the next page

- (c) If you are lost in the woods, your best chance of finding your way may be a tiny magnet. A magnet is what makes a compass point north. The magnet in a compass is suspended so that it can spin freely and come to rest in a north-south direction.

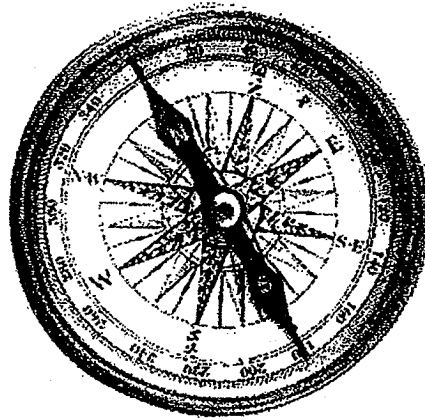

Leonard then puts three compasses close together. Label the North and South magnetic poles on each of the three compasses. One pole has been labelled for you. [1]

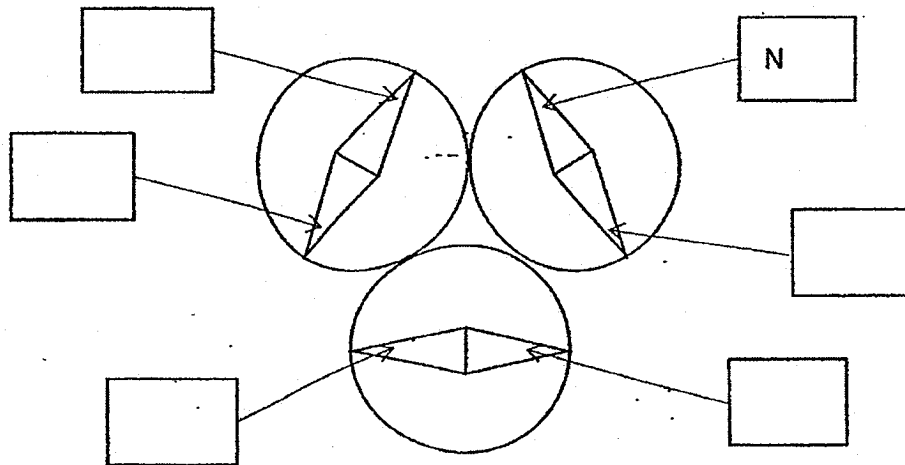

Score	3
-------	---

End of Paper

EXAM PAPER 2018(P6)

SCHOOL : NAN HUA

SUBJECT : SCIENCE

TERM : SA1

Q1	Q2	Q3	Q4	Q5	Q6	Q7	Q8	Q9	Q10
1	2	3	1	4	1	1	4	1	3
Q11	Q12	Q13	Q14	Q15	Q16	Q17	Q18	Q19	Q20
1	2	1	1	1	1	2	3	3	4
Q21	Q22	Q23	Q24	Q25	Q26	Q27	Q28		
4	3	4	1	3	4	2	4		



29a. The greater the light intensity, the greater the number of insects found at the bottom of the bottle.

29b. Insects living in leaf litter prefer living in dark places. When light is shone on them, they will move to a place with their preferred condition.

29c. Living things can respond to changes /stimuli.

30a. Field habitat

30b. 2

30c. 1. Increase the population of birds, so that more birds will eat the snail.

2. Decrease the number of snakes, so that there is less snakes to eat the birds. Then more bird will eat more snail.

31a. Seed A is dispersed by animals

31b. Being juicy and fleshy will attract the animals to eat the fruit. The seeds will either be thrown away or pass out in droppings after some distance.

31c. By water. The young plants are growing along the river. Dispersed further away from parent plant.

31d. Fruit B. Fruit B has a fibrous husk which has air spaces. The air spaces helps fruit B to float in water. The seeds will germinate along the river.

32a. The same amount of water is used to ensure that it will not affect the amount of water collected in the beaker.

32b. Repeat the experiment a few times.

32c. Soil B. No water was collected in the cylinder. Mangrove swamp has soil that has no air spaces. Thus, no water can flow through soil B.

33a. E

33b. No. None of the organisms is both a prey and a predator. B, C and D are only prey. E is only a predator.

33c. The organisms will use some of the energy for life processes, so less energy is passed from one organism to the next organism. The last few organisms in the food chain will not have enough energy for life processes.

34a. B, C

34b. The weight of the iron block exerts a pulling force on the spring to stretch it.

34c. Spring A. For the same force applied, Spring A stretches less than B.

35a. Food

35b. Some of the gravitational potential energy has been converted to other forms of energy such as heat and sound energy.

35c. Lift the mass higher /
Push the mass down harder /
Oil the rod .

36a. Conductor of electricity

36b. T conducts electricity best, followed by R and then S

36c. Salt water in the sea is a good conductor of electricity and Rajesh may get electrocuted by lightning.

37a. | gravity

| air resistance

37b. The speed of the falling BASE jumper decreases.
When the parachute opens, there is more air resistance acting on the jumpers, slowing down his fall.

38a. CPE → EE → HE

38b. The laptop computer will need to be recharged faster.
Because some of the CPE in the laptop computer is converted to electrical energy for the heater to work.

38c. Metal is a better conductor of heat than plastic. So the drink will gain heat faster from the heater.

39a. The water in the wet towel would flow downwards as gravity pulls it down.

39b. The weather becomes hotter / more windy / less humid.

39c. The water on her hair will gain heat from her body and evaporated. Her body loses heat, hence she feels cooler.

40a. He should have stroked the iron nail with a magnet instead of using the steel rod.

40b. He can increase the number of times the iron nail is stroked with the magnet.

40c.

