



Anglo-Chinese School (Junior)  
Anglo-Chinese School (Primary)

**PRELIMINARY EXAMINATION 2018  
PRIMARY SIX  
SCIENCE  
BOOKLET A**

**Name:**

**Class: Primary 6**

**Date: 28 August 2018**

**Duration of paper: 1 h 45 min**

**INSTRUCTIONS TO CANDIDATES**

1. Write your name, register number and class.
2. Do not turn over this page until you are told to do so.
3. Follow all instructions carefully.
4. Answer all questions.
5. Shade your answer on the Optical Answer Sheet (OAS) provided.
6. This question paper consists of 16 printed pages including this cover page.



**PART I**

For each question from 1 to 28, four options are given. One of them is the correct answer. Make your choice (1, 2, 3 or 4) and shade your answer on the Optical Answer Sheet. (56 marks)

1 The diagram shows a plant.

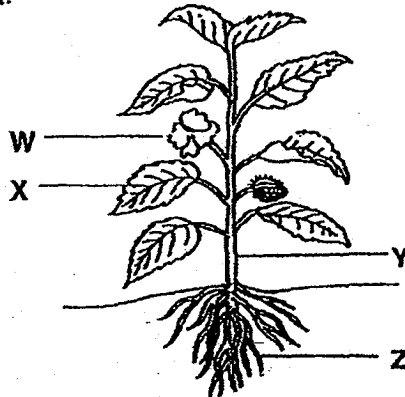

Which parts of the plant work together to enable it to make food?

- (1) W and Y only
- (2) X and Z only
- (3) X, Y and Z only
- (4) W, X, Y and Z

2 The diagrams show the life cycles of organisms M and N.

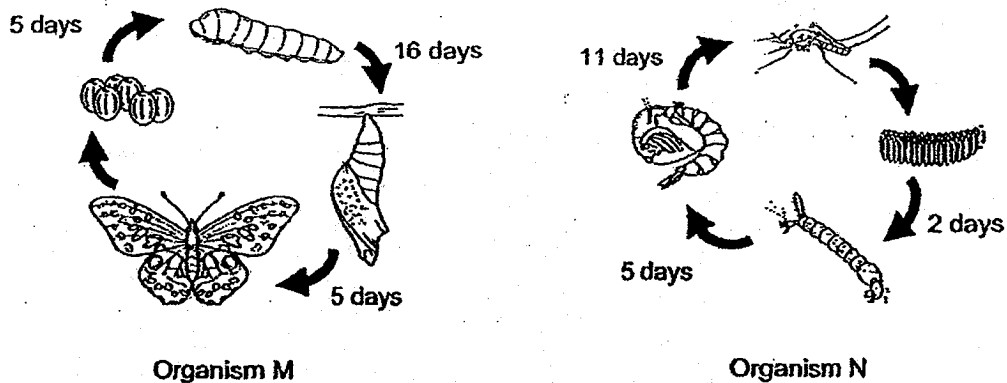

Based on the information above only, which of the following statement(s) about organisms M and N is/are true?

- A The young of N resembles its adult but the young of M does not.
- B The pupa of N takes a longer time to develop into an adult than M.
- C The larva of N takes a longer time to develop into an adult than M.
- D The young of N feeds on leaves only but the young of M does not.

- (1) B only
- (2) C only
- (3) A and B only
- (4) C and D only

(Go on to the next page)

- 3 The diagram below shows the cross section of the parts of a flower and a fruit.

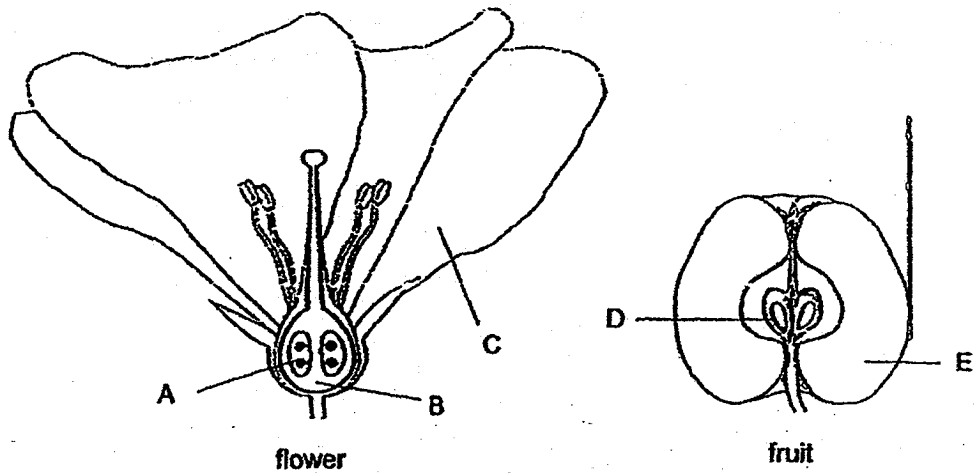

Which of the following statement(s) is/are correct after fertilisation has taken place in the flower in order to form the fruit?

- X Part C wilts and falls off.
- Y Part A develops into part D.
- Z Part B develops into part E.

- (1) Z only
  - (2) X and Y only
  - (3) Y and Z only
  - (4) X, Y and Z
- 4 Which of the following human body system(s) work together to provide energy for daily activities?

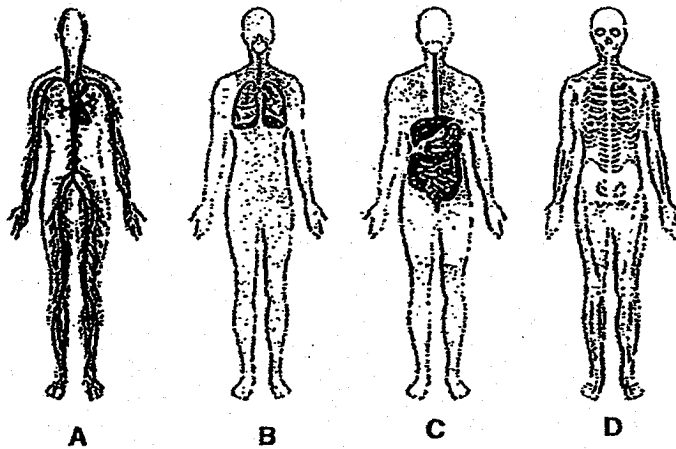

- (1) D only
- (2) B and C only
- (3) A and D only
- (4) A, B and C only

- 5 Charles used three similar plants, A, B and C, to conduct an experiment. He removed all the leaves from Plant A, and some leaves from Plant C. He then put the three plants in three identical containers with the same amount of water and placed them in the same location. After five days, Charles measured the height of the water in each container.

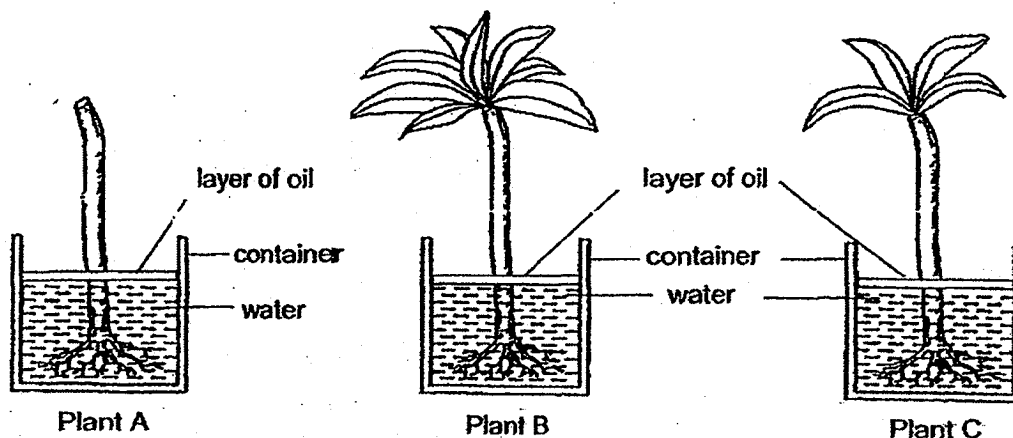

The aim of his experiment is to find out if \_\_\_\_\_.

- (1) the leaves of the plant absorb water
  - (2) the plant needs roots to absorb water
  - (3) the stem of the plant helps to transport water from the roots to the leaves
  - (4) the number of leaves affects the rate of water absorbed by the roots of the plant
- 6 The diagram shows the movement of food and water in a plant.

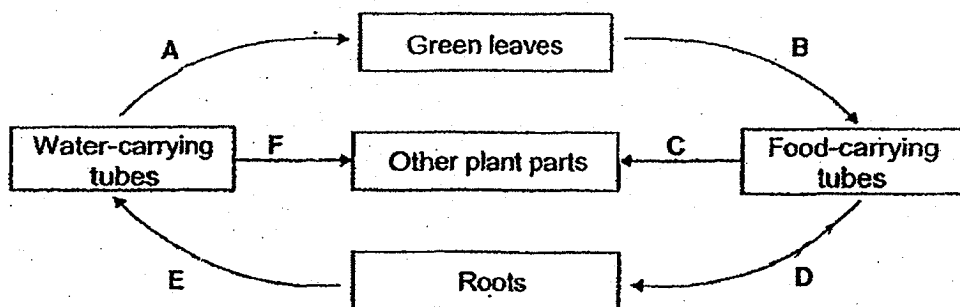

Which arrows represent the movement of water?

- (1) A B and C only
- (2) A, E and F only
- (3) B, C and D only
- (4) D, E and F only

- 7 The diagram shows how water can be separated from a mixture of soil and water using a filter paper.

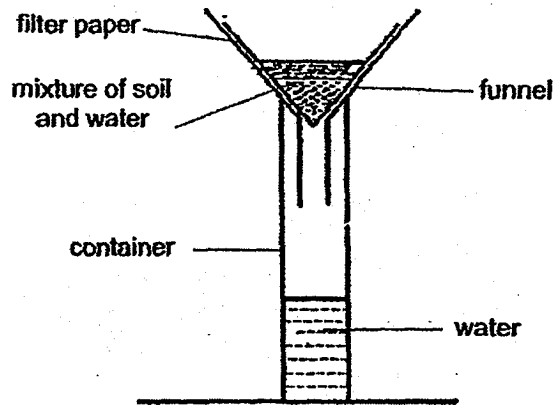

Which part of the cell has same function as the filter paper?

- (1) nucleus
  - (2) cell wall
  - (3) cytoplasm
  - (4) cell membrane
- 8 The arrows in the diagram represent blood vessels. S and V are parts of the body.

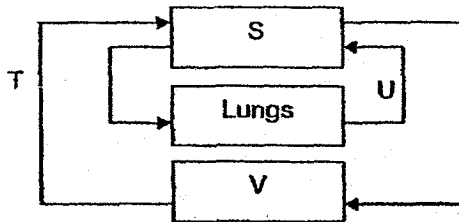

What do S, T, U and V represent?

|     | S            | T                            | U                            | V            |
|-----|--------------|------------------------------|------------------------------|--------------|
| (1) | Rest of body | Carries blood rich in oxygen | Carries blood poor in oxygen | Heart        |
| (2) | Heart        | Carries blood poor in oxygen | Carries blood rich in oxygen | Rest of body |
| (3) | Heart        | Carries blood rich in oxygen | Carries blood poor in oxygen | Rest of body |
| (4) | Rest of body | Carries blood poor in oxygen | Carries blood rich in oxygen | Heart        |

- 9 A coconut seedling was found on the beach as shown in the picture.



Which one of the statements below is true about the seedling?

- (1) The seedling can start making food.
  - (2) Fertilisation can take place at this time.
  - (3) The seedling can only grow in the water.
  - (4) The leaves can absorb water from the sea to make food.
- 10 Study the food web.

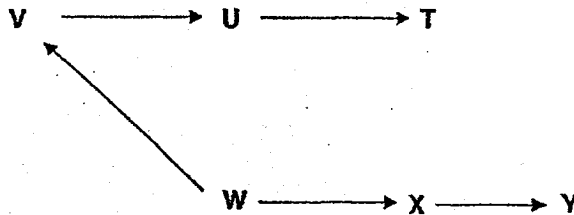

Based on the food web, which organisms will be affected immediately when all of organism U die?

- (1) V and T only
- (2) V and X only
- (3) W and Y only
- (4) T and Y only

- 11 A farmer used a certain amount of fertiliser on his farm. Some of this fertiliser flowed into a nearby river which contained some bacteria, plants and fish. The water in the river became very murky and a number of events happened after that.

The table shows the events that happened in the river after that but they are not in the correct order.

| Event | Description                                      |
|-------|--|
| A     | The population size of the fish decreased.       |
| B     | Bacteria used the nutrients to reproduce faster. |
| C     | The amount of oxygen in the river decreased.     |
| D     | The amount of nutrients increased.               |

Arrange the events in the correct order of its occurrence (first to last)

- (1) A, D, B, C  
 (2) B, A, C, D  
 (3) C, A, B, D  
 (4) D, B, C, A
- 12 The diagram shows the organisms living in a pond.

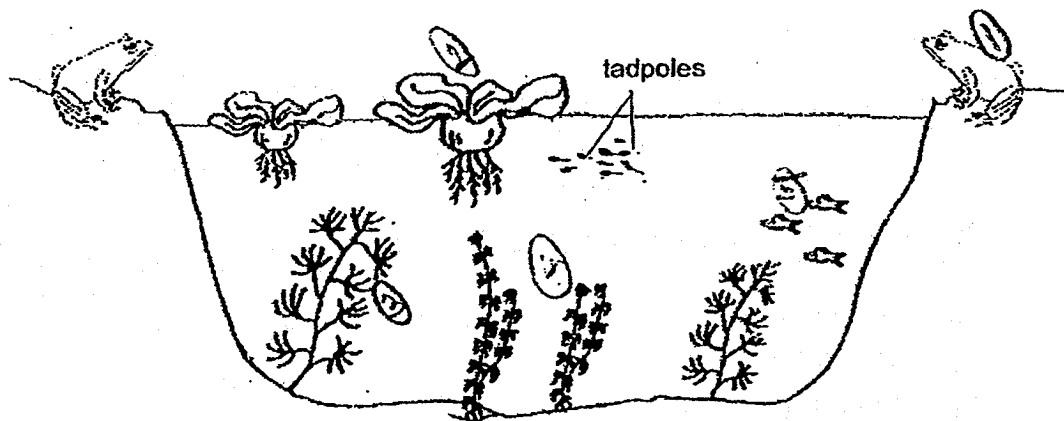

How many populations can you observe from the diagram?

- (1) 3  
 (2) 5  
 (3) 6  
 (4) 17



- 13 Some solid pieces of substance J were taken out of a freezer and placed in a U-shaped container. After 15 minutes, it was observed that all of the solid substance J had melted completely as shown.

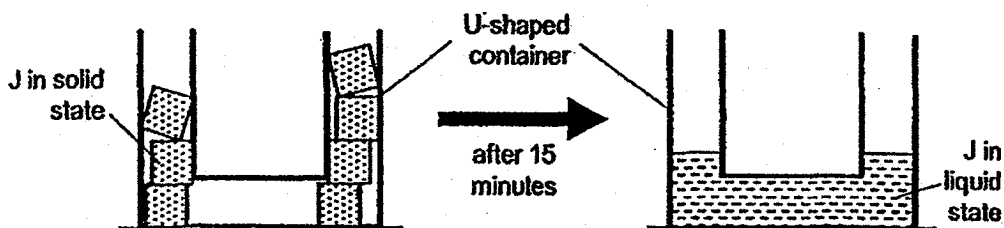

Based only on the information above, which of the following statements are true?

- A J in the solid state has no definite shape.
- B J in the liquid state has a definite volume.
- C J in the liquid state has no definite shape.
- D J in the solid state has no definite volume.

- (1) A and B only
- (2) C and D only
- (3) B and C only
- (4) A, B and D only

- 14 Which of the following actions would help to conserve water?

- P Taking long showers on a hot day.
- Q Turn off the running tap while brushing your teeth.
- R Reuse water used for washing rice to water plants.
- S Using the washing machine to wash a dirty pair of socks.

- (1) P and Q only
- (2) Q and R only
- (3) P, R and S only
- (4) Q, R and S only

- 15 The diagram represents the water cycle.

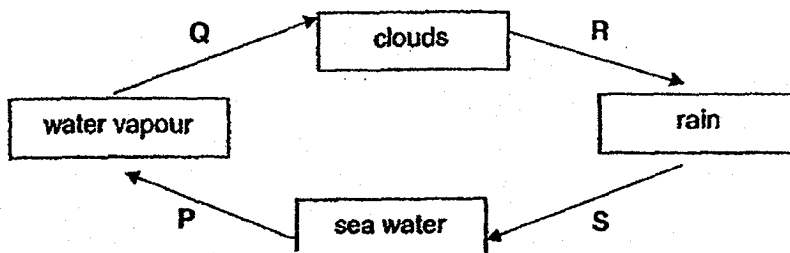

Based on the diagram, which letter(s), P, Q, R and/or S, represent(s) the process where heat is lost?

- (1) R only
  - (2) Q only
  - (3) P and S only
  - (4) Q and R only
- 16 Two set-ups, A and B, were placed in a classroom as shown in the diagram.

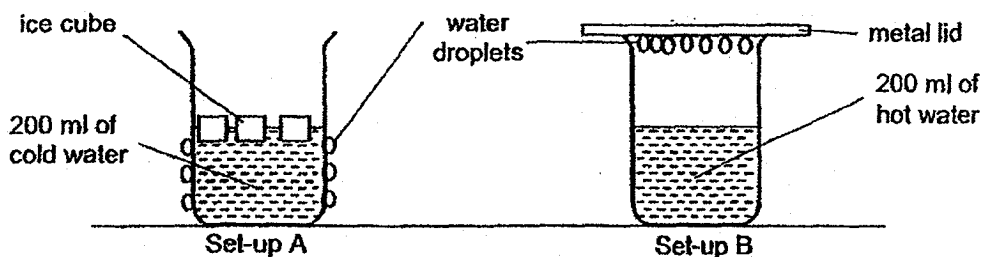

Where did the water droplets in set-up A and B come from?

|     | Set-up A        | Set-up B                   |
|-----|-----------------|----------------------------|
| (1) | ice cubes       | water vapour in the beaker |
| (2) | cold water      | hot water                  |
| (3) | ice cubes       | surrounding air            |
| (4) | surrounding air | water vapour in the beaker |

- 17 The diagrams below shows four circuits, A, B, C and D with different arrangements of identical batteries and bulbs. The bulbs in all four circuits light up.

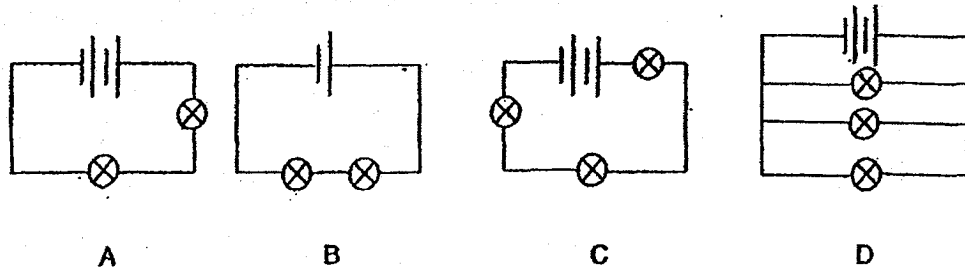

Which one of the following shows the correct brightness of the bulbs?

|     | Brightness of bulb |   |   |           |
|-----|--------------------|---|---|-----------|
|     | Dimmest            |   |   | Brightest |
| (1) | A                  | B | C | D         |
| (2) | B                  | C | A | D         |
| (3) | C                  | B | A | D         |
| (4) | B                  | C | D | A         |

- 18 The diagram shows four different set-ups of identical batteries, bulbs and wires that are in working condition.

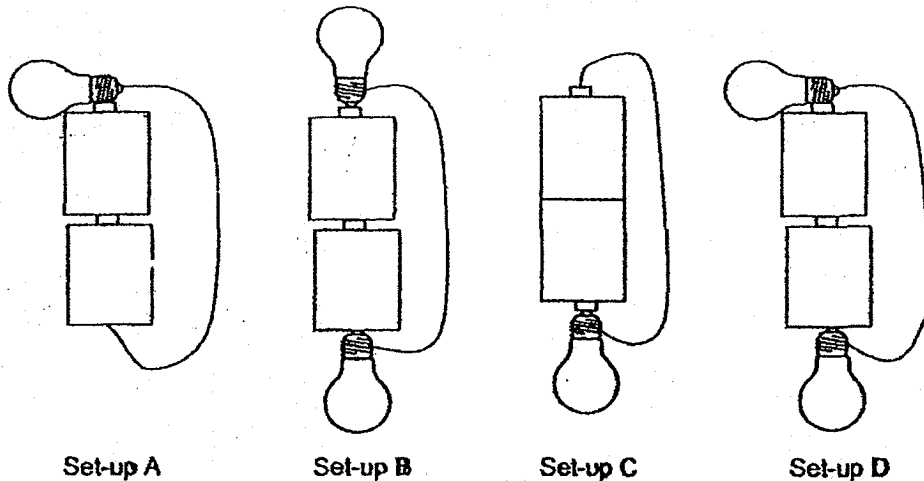

In which set-ups, A, B, C and D will the bulb(s) light up?

- (1) A and D only
- (2) B and C only
- (3) A, B and D only
- (4) A, B, C and D

- 19 Pei Ling used a silver stick, a battery and some wires to set up the circuit as shown.

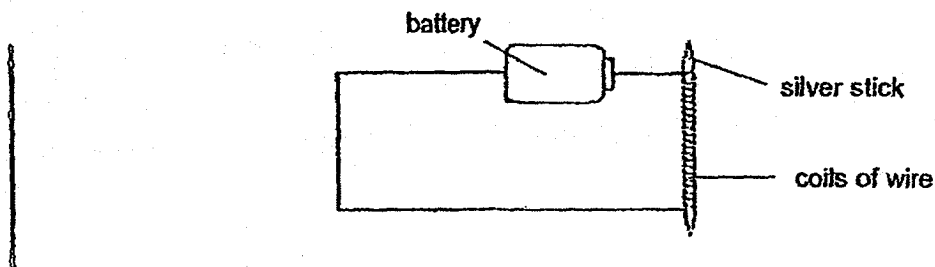

She then increased the number of batteries connected in a series in the circuit from one to two and then three. She then counted the maximum number of staples attracted to the silver stick each time.

Which one of the following bar graphs shows the results she will obtain?

(1)

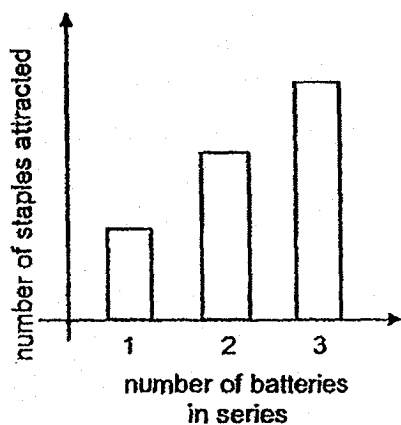

(2)

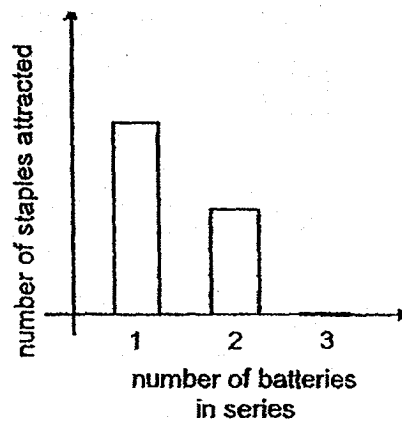

(3)

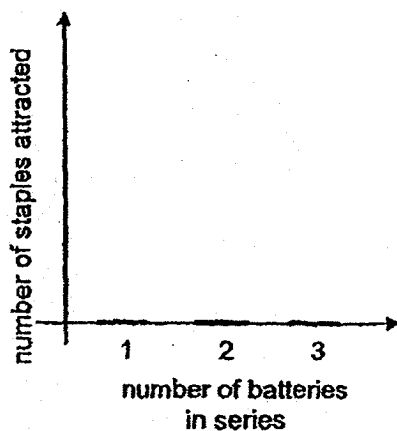

(4)

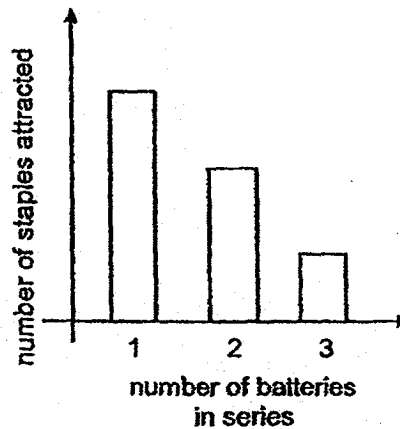

20 Devi set up an electromagnet and placed it in between an aluminium rod and a magnet as shown.

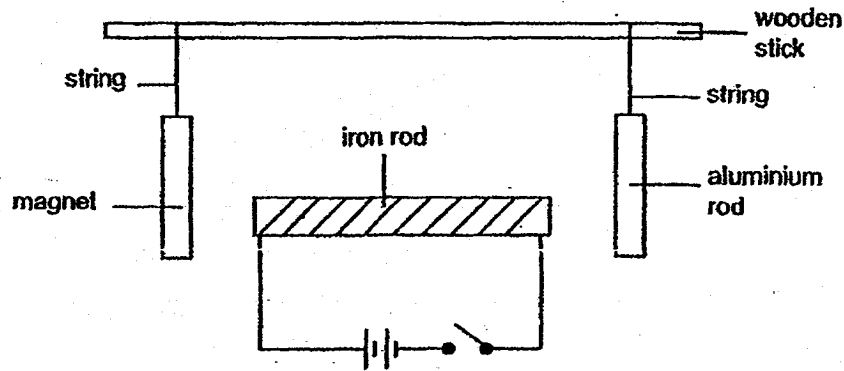

When the switch is closed, which of the following are possible observations she will make?

- A The magnet moves to the left.
- B The magnet moves to the right.
- C The aluminium rod moves to the left.

- (1) A and B only
- (2) A and C only
- (3) B and C only
- (4) A, B and C

21 The diagram shows a box being dragged along the ground by a boy.

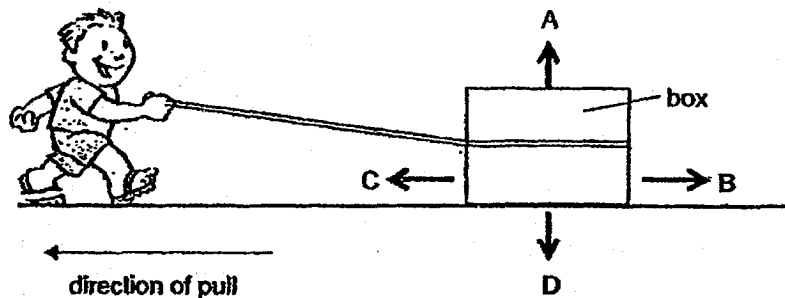

Which of the arrows above show correctly the directions that frictional force and gravitational force are acting on the box?

|     | Frictional Force | Gravitational Force |
|-----|------------------|---------------------|
| (1) | B                | D                   |
| (2) | C                | D                   |
| (3) | A                | C                   |
| (4) | B                | A                   |

- 22 A wooden block was pulled up a ramp using a spring balance as shown below and the amount of force needed to pull it was then recorded. The experiment was repeated but the angle of inclination ( $A^\circ$ ) was increased by  $5^\circ$  each time.

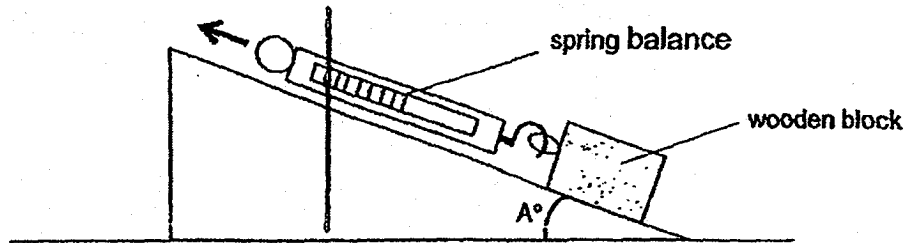

Which one of the following graphs correctly shows the results of the experiment above?

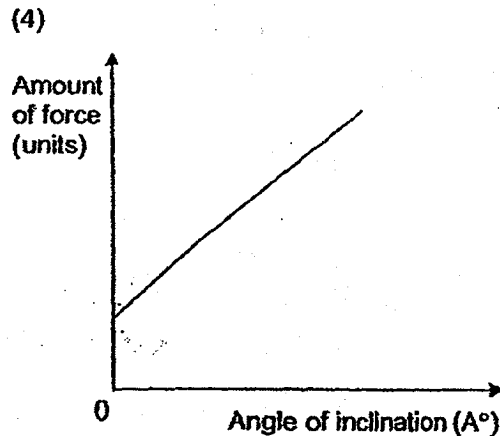
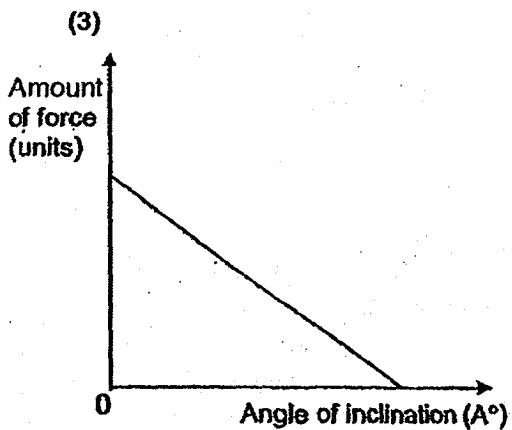
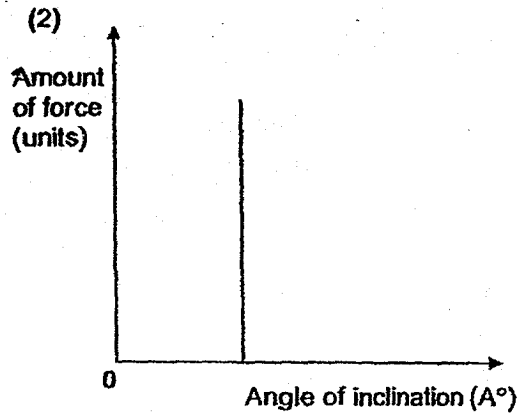
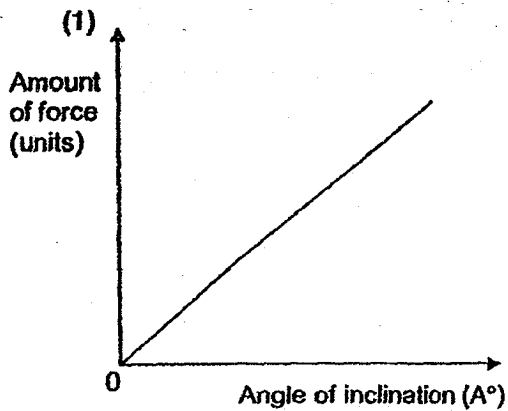

- 23 Tom placed a torchlight at the 1 cm mark of a ruler. It shone at an object that was placed at the 4 cm mark of the ruler as shown. A shadow was cast on the screen.

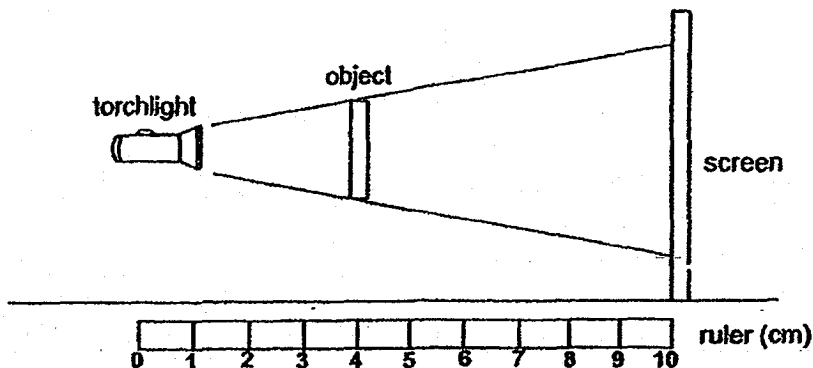

Tom adjusted the position of the torchlight and/or object. Which of the following two combinations of the positions of the torchlight and object will cast a smaller shadow on the screen?

|   | Position of torchlight (cm) | Position of object (cm) |
|---|-----------------------------|-------------------------|
| A | 0                           | 4                       |
| B | 1                           | 3                       |
| C | 2                           | 4                       |
| D | 1                           | 5                       |

- (1) A and B  
 (2) B and C  
 (3) C and D  
 (4) A and D
- 24 Study the actions listed below.
- A Burning a log of wood.  
 B Dropping a ball onto the floor.  
 C Rubbing your hands together.  
 D Switching on an electric table fan.

Which of the following shows the energy conversions in all the actions correctly?

|     | A                               | B                                  | C                                   | D                                   |
|-----|---------------------------------|------------------------------------|-------------------------------------|-------------------------------------|
| (1) | Kinetic energy to heat energy   | Potential energy to heat energy    | Kinetic energy to electrical energy | Kinetic energy to potential energy  |
| (2) | Potential energy to heat energy | Potential energy to kinetic energy | Kinetic energy to heat energy       | Electrical energy to kinetic energy |
| (3) | Kinetic energy to heat energy   | Potential energy to heat energy    | Potential energy to kinetic energy  | Electrical energy to kinetic energy |
| (4) | Kinetic energy to heat energy   | Kinetic energy to potential energy | Potential energy to heat energy     | Kinetic energy to electrical energy |

25. Two glasses, A and B were stuck together as shown in the diagram.

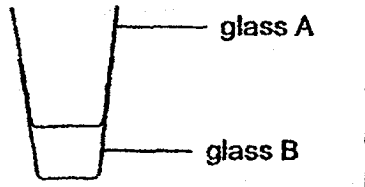

Which of the methods shown below would enable glass A to be separated from glass B in the shortest possible time?

|   |   |
|---|---|
| <p>(1)</p> <p>Labels: glass A, hot water, ice, glass B, basin</p> | <p>(2)</p> <p>Labels: glass A, freezer, glass B</p>               |
| <p>(3)</p> <p>Labels: glass A, hot water, glass B, basin</p>      | <p>(4)</p> <p>Labels: glass A, ice, hot water, glass B, basin</p> |

26. Four identical iron blocks were heated to a temperature of 90°C. Each block was then dropped into a beaker of water as shown in the diagrams.

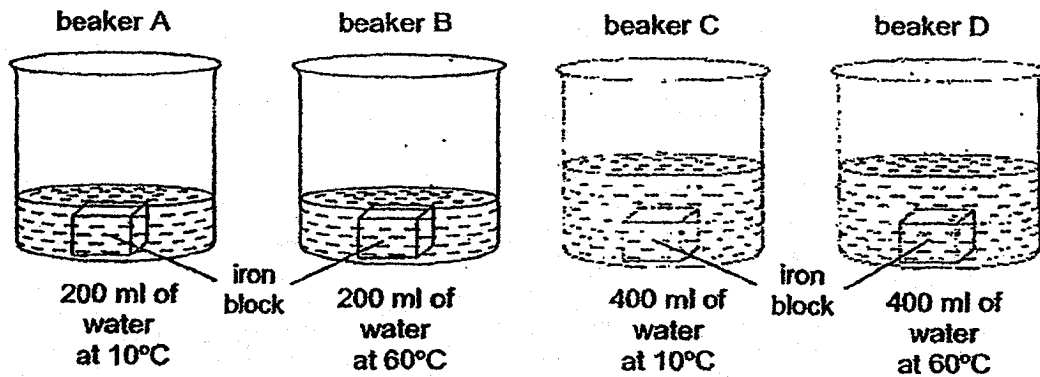

Which of the following correctly indicates the beakers with water at the lowest and highest temperature two minutes after the blocks were dropped in them?

|     | Beaker of water with the lowest temperature | Beaker of water with the highest temperature |
|-----|---|--|
| (1) | A   | D  |
| (2) | B   | C  |
| (3) | C   | B  |
| (4) | D   | A  |



- 27 A beaker of ice was heated over a bunsen burner, with the temperature of the contents taken and recorded over time. The results were plotted in the graph.

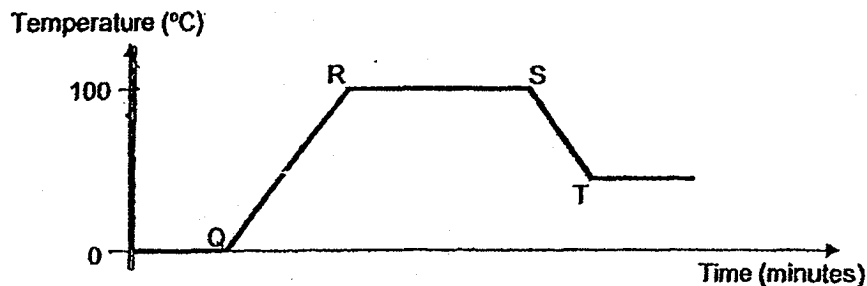

Which of the following statements are true?

- A The water stopped boiling after S.
- B The ice was completely melted at Q.
- C The bunsen burner was turned off at R.
- D There was no change of state in the water from Q to R.

- (1) A and B only
  - (2) B and C only
  - (3) C and D only
  - (4) A and D only
- 28 Ryan wanted to investigate if the mass of an object affects the amount of energy it possesses, using the set-ups as shown.

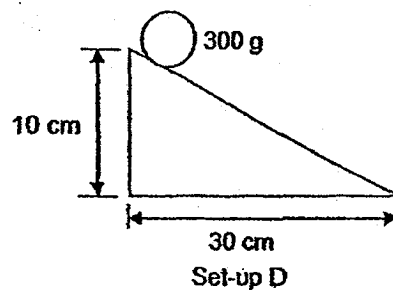
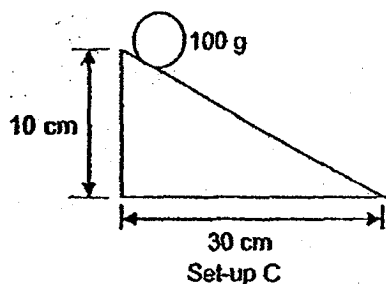
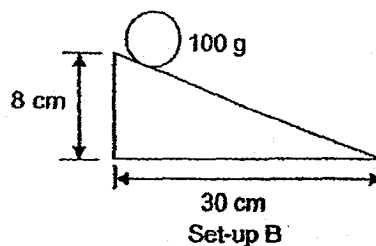
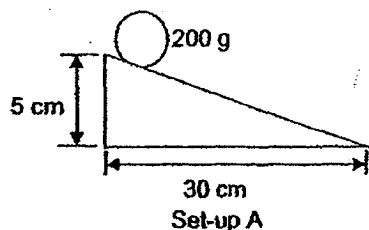

Which of the following set-ups should he use in his experiment?

- (1) A and B only
- (2) B and C only
- (3) C and D only
- (4) A and D only



Anglo-Chinese School (Junior)  
Anglo-Chinese School (Primary)

**PRELIMINARY EXAMINATION 2018  
PRIMARY SIX  
SCIENCE  
BOOKLET B**

Name:

Class: Primary 6

Date: 28 August 2018

Duration of paper: 1 h 45 min

\_\_\_\_\_  
Parent's/Guardian's Signature

**INSTRUCTIONS TO CANDIDATES**

1. Write your name, register number and class.
2. Do not turn this page until you are told to do so.
3. Follow all instructions carefully.
4. Answer all questions.
5. Write your answers in this booklet.
6. This question paper consists of 16 printed pages including this cover page.

| BOOKLET | POSSIBLE MARKS | MARKS OBTAINED |
|---------|----------------|----------------|
| A       | 56             |                |
| B       | 44             |                |
| Total   | 100            |                |

**PART II**

For questions 29 to 40, write your answers in this booklet.

The number of marks available is shown in brackets [ ] at the end of each question or part question. (44 marks)

- 29 The diagram shows an umbrella made of different materials.

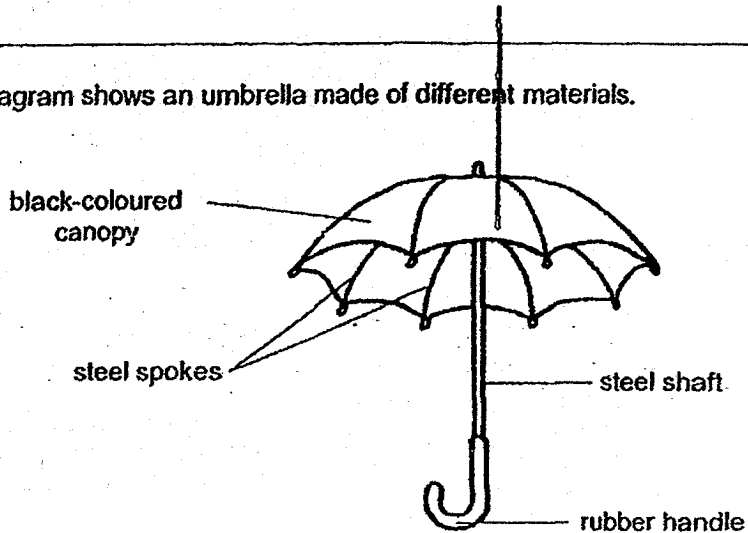

- (a) State an important property that the material of the canopy must possess that makes it suitable for use in an umbrella. Explain clearly why the property is required in an umbrella. [1]

---



---

- (b) In what way is rubber a more suitable material than steel to make the handle? Explain your reasoning clearly. [1]

---



---

- (c) What would be an advantage to the user if the canopy is made of a transparent material? Explain your answer clearly. [1]

---



---

(Go on to the next page)

|       |   |
|-------|---|
| SCORE | 3 |
|-------|---|

- 30 Lynn wanted to transfer some shampoo from a bigger plastic bottle into a smaller plastic bottle as shown.

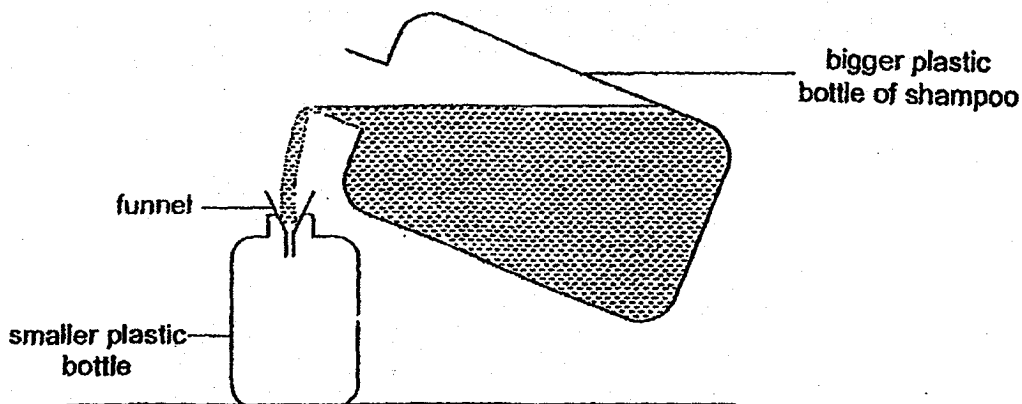

She started to pour the shampoo carefully into the smaller bottle using a funnel. At first, she noticed that some shampoo entered the smaller bottle easily. However, after a while, she noticed that the shampoo did not flow into the smaller bottle but overflowed instead even though the smaller bottle was obviously still not full.

- (a) State the property of the shampoo which allowed it to be poured into the smaller bottle. [1]

---



---

- (b) Explain why the shampoo overflowed even though the smaller bottle was not full yet. [2]

---



---



---



---

- (c) Suggest an action she can take to fill the smaller bottle faster without causing any damage to the bottle and funnel. [1]

---



---

(Go on to the next page)

|       |   |
|-------|---|
| SCORE | 4 |
|-------|---|

31 (a) State one difference between evaporation and boiling.

[1]

---



---

(b) Sam bought some hot fried noodles which were placed in a cardboard container as shown.

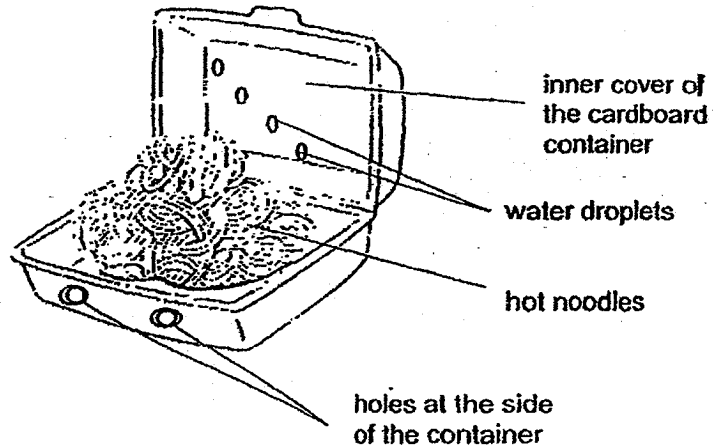

He opened the cover after five minutes and observed that there were water droplets formed on the inner portion of the cover of the cardboard container. Explain how the water droplets were formed. [2]

---



---



---

(c) Sam observed that there were holes at the side of the cardboard container. He suggested increasing the size of the holes. How will this make the noodles cool down faster? Explain your answer. [1]

---



---

(Go on to the next page)

|       |   |
|-------|---|
| SCORE | 4 |
|-------|---|

- 32 A thick ring of a stem of a plant was removed as shown in the diagram below. As a result, the tubes carrying food and water were removed.

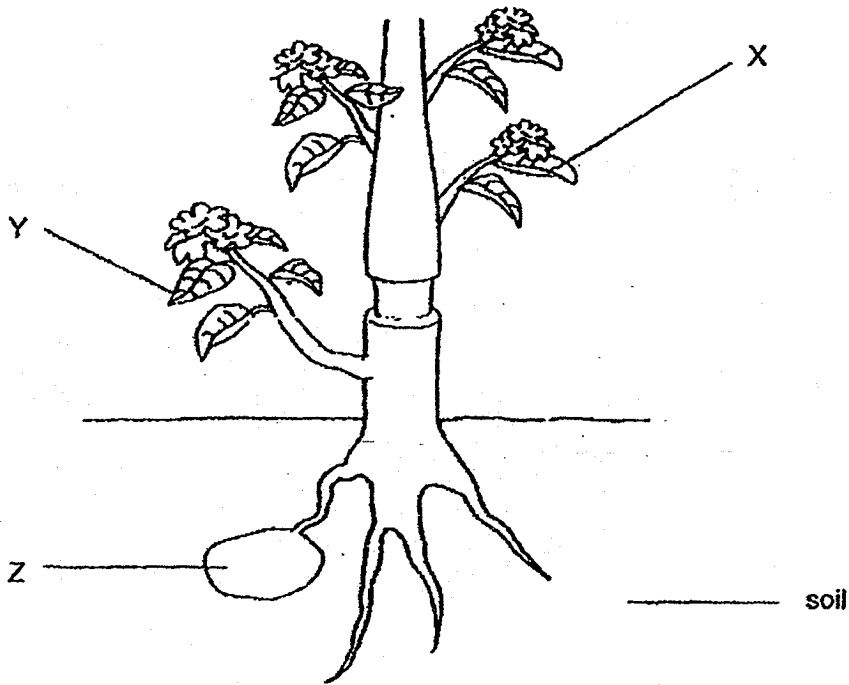

- (a) What is needed for photosynthesis to take place? [1]
- \_\_\_\_\_
- \_\_\_\_\_
- (b) After a week, it was observed that the leaves at X turned yellow and wilted but the leaves at Y remained green. Explain clearly what caused the leaves at X to turn yellow and wilt, and why the leaves at Y could remain green. [2]
- \_\_\_\_\_
- \_\_\_\_\_
- \_\_\_\_\_
- (c) Structure Z is where the plant stores its food. Predict whether Z will grow bigger or smaller after the thick ring of the stem is removed, explaining clearly the reason why this happens. [1]
- \_\_\_\_\_
- \_\_\_\_\_

(Go on to the next page)

|       |   |
|-------|---|
| SCORE |   |
|       | 4 |

- 33 The graph shows Mike's heart rate for a period of time as he went about his daily activities.

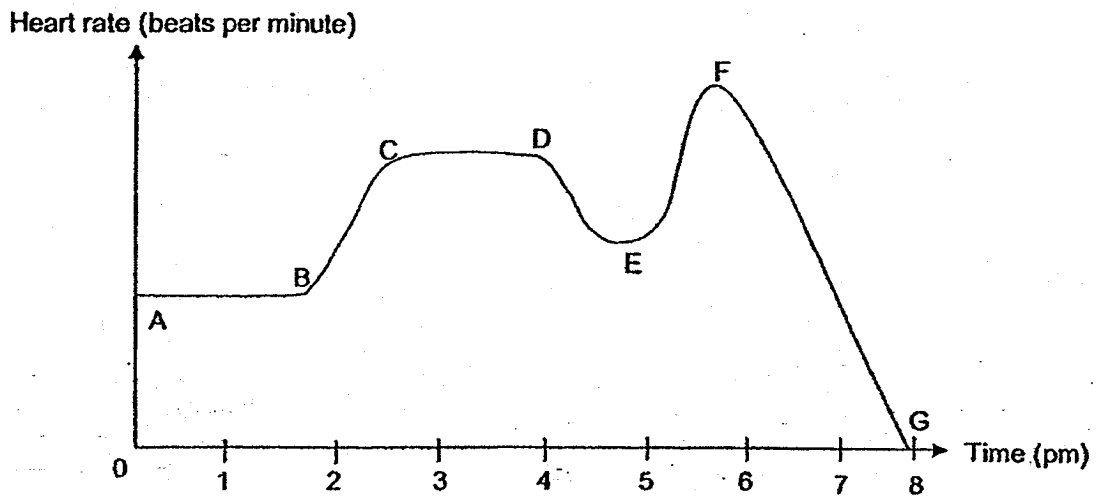

- (a) Which part of the line graph is incorrect? Explain why. [1]

---



---

- (b) Explain why his heart rate increased as the intensity of his activities increased. [2]

---



---



---



---

(Go on to the next page)

|       |   |
|-------|---|
| SCORE | 3 |
|-------|---|

34 Billy plays a game called "Buzz Wire" which has a bulb and batteries which are new and in working condition. He has to guide the metal loop through the wire maze from point X to point Y without touching the metal loop against the wire maze. If the metal loop touches the wire maze, the bulb will light up.

(a) Complete the diagram below, by drawing wires to connect the components so that the game will work. [1]

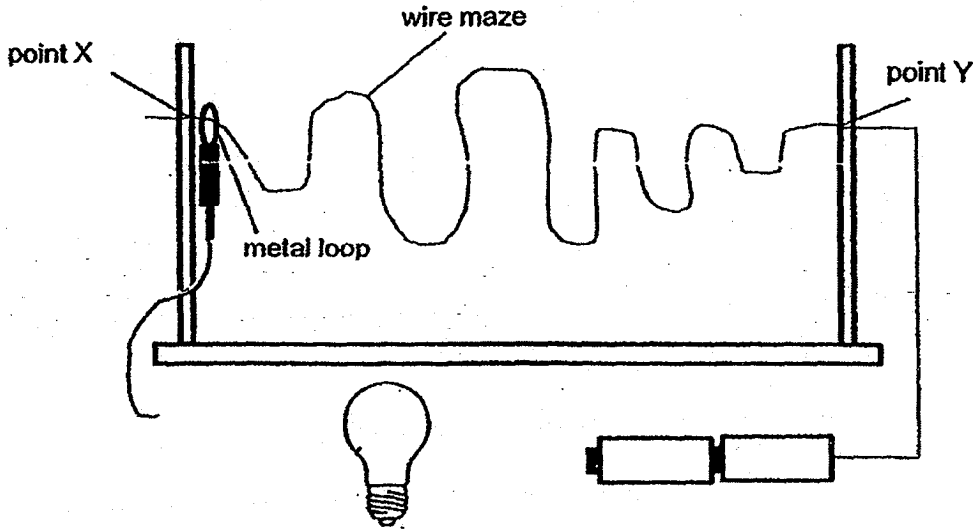

(b) Why did the bulb light up when the metal loop touched the wire maze? [1]

---



---

When Billy added another bulb to the "Buzz Wire", he observed that the two bulbs became dimmer.

(c) Give a reason why the bulbs were dimmer. [1]

---

(d) After a few minutes, Billy noticed that the bulbs did not light up when the metal loop was in contact with the wire maze. Suggest a possible reason for this. [1]

---

(Go on to the next page)

|       |   |
|-------|---|
| SCORE | 4 |
|-------|---|



- 35 Victor conducted an experiment by using steel clips, two identical iron rods, wires and batteries for set-ups P and Q as shown.

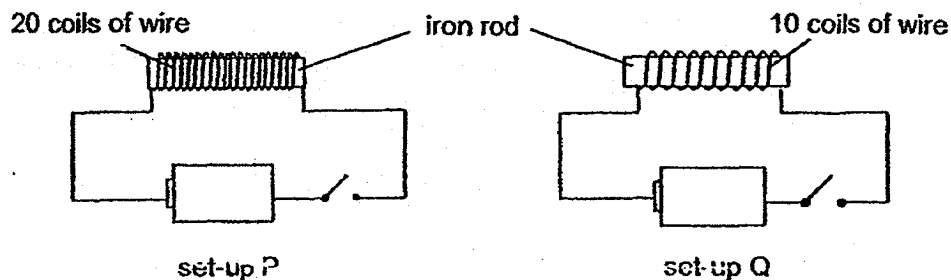

When each switch was closed, he observed some steel clips were attracted and counted the number of steel-clips each iron rod attracted.

- (a) Based on the diagram above, state the aim of his experiment. [1]

---



---

- (b) Using only the materials in the experiment above, suggest and explain another method that Victor can use to decide which electromagnet is stronger? [2]

---



---



---



---

- (c) State one other action Victor can take to further increase the magnetic strength of the electromagnet in set-up Q. [1]

---



---

(Go on to the next page)

|       |   |
|-------|---|
| SCORE | 4 |
|-------|---|

- (d) Electromagnets are often used to lock doors as shown in the diagram.

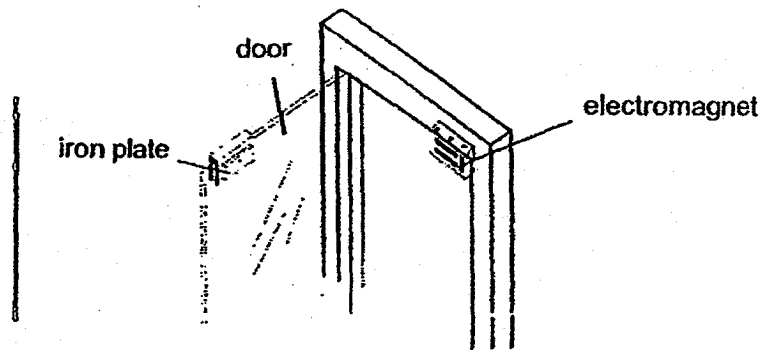

Explain why an electromagnet is used instead of a permanent magnet for such doors. [1]

---

---

(Go on to the next page)

|       |   |
|-------|---|
| SCORE | 1 |
|-------|---|

- 36 A marble was pushed with the same amount of force across four different types of surfaces, Q, R, S and T. For each surface, the experiment was repeated a few times and the table shows the average distance travelled by the marble before it came to a stop.

| Surface                                       | Q  | R  | S  | T  |
|---|----|----|----|----|
| Average distance travelled by the marble (cm) | 78 | 19 | 28 | 55 |

- (a) Using the results from the table above, state which surface could be the roughest. Give a reason for your answer. [1]

---



---

- (b) Why is there a need to repeat the experiment a few times and to calculate the average distance travelled by the marble for each surface tested? [1]

---



---

Michael recently visited his grandmother in the hospital and saw that she was wearing special socks to prevent falls as shown in the picture.

tiny bumps  
found on the  
bottom side of  
the socks

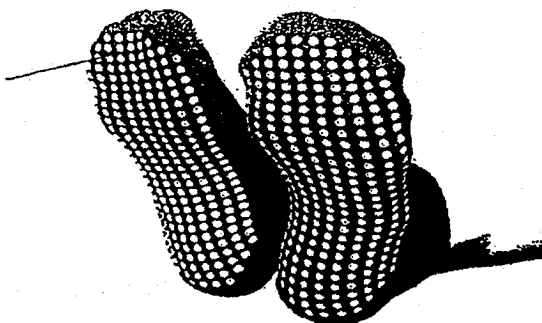

- (c) How does wearing these special pairs of socks prevent falls? [1]

---



---

(Go on to the next page)

|       |   |
|-------|---|
| SCORE | 3 |
|-------|---|

37 Ali prepared two set-ups to find out if the amount of vinegar affects the amount of paint to come off metal M.

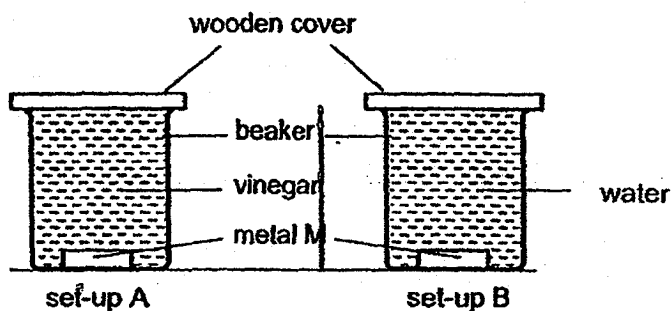

(a) What should Ali change in set-up B to carry out a fair test? [1]

---



---

The diagram below shows black smoke coming out from the chimneys of a factory.

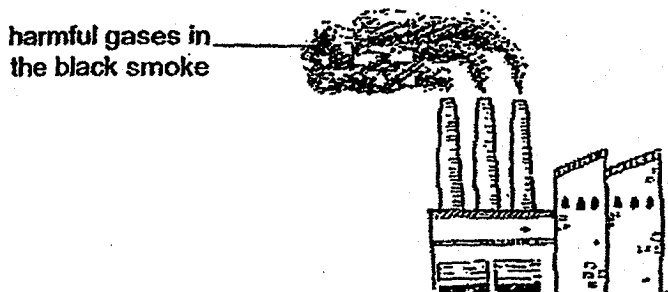

(b) It was observed that the paint from the bodies of cars near this factory came off during the rainy season. Explain how the harmful gases present in the black smoke from the factory may have caused this. [2]

---



---



---



---

(Go on to the next page)

|       |   |
|-------|---|
| SCORE | 3 |
|-------|---|

38 Danny conducted an experiment using three identical pieces of glass, L, M and N. They were tilted at different angles as shown below. Glass N was not tilted.

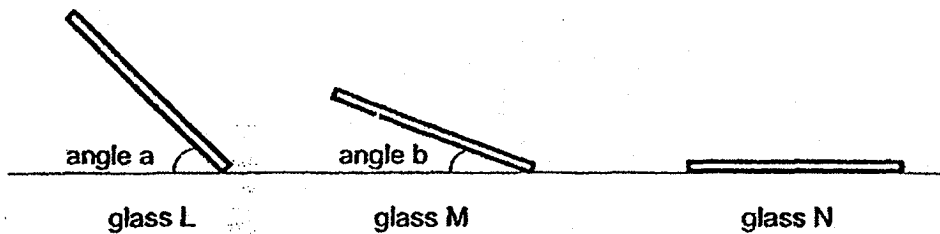

Danny prepared the setup as shown for each piece of glass. He allowed the fan to blow at the surface of the hot water for the same duration of time. He observed water droplets forming on each glass and flowing down the glass pieces. He measured and recorded the amount of water collected in the empty container.

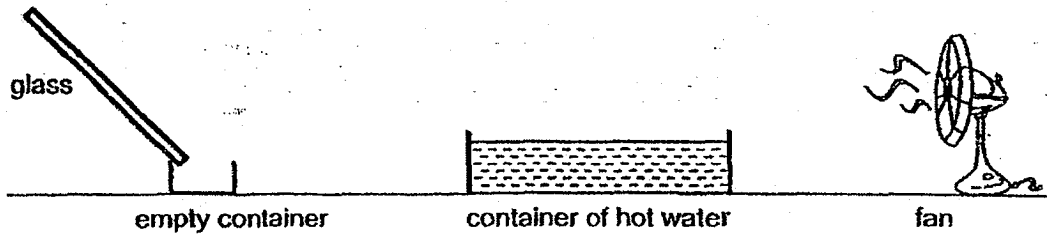

The table below shows his result.

| Glass   | L  | M  | N |
|---|----|----|---|
| Amount of water collected in the empty container (ml) | 20 | 12 | 4 |

Two beetles of the same kind and size, P and Q, obtain water by sticking their rear ends up in the air so that they face the wind which is rich in water vapour as shown in the diagram. The water collected on their backs flows down towards their head and mouth.

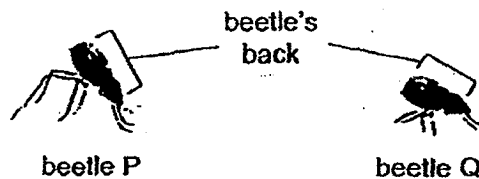

(a) Based on the results of Danny's experiment, explain now beetle P obtained more water than beetle Q. [2]

---



---



---

(Go on to the next page)

|       |   |
|-------|---|
| SCORE | 2 |
|-------|---|

- (b) In addition, it was observed that Beetle P's back also has many bumps as shown in the diagram.

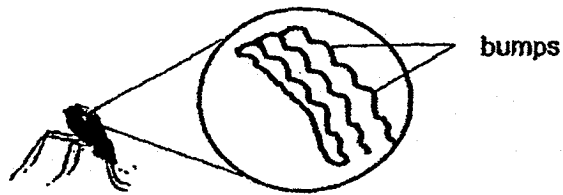

Explain how this enables Beetle P to obtain more water from the environment? [1]

---

---

(Go on to the next page)

|       |  |
|-------|--|
| SCORE |  |
|-------|--|

- 39 The diagram below shows three identical glasses, A, B and C, filled with different amounts of water at different temperatures, placed on three identical hotplates. The water in the three glasses were originally at 30°C, before the glasses were placed on the electrical hotplates and heated at the same starting time, to reach their final temperatures.

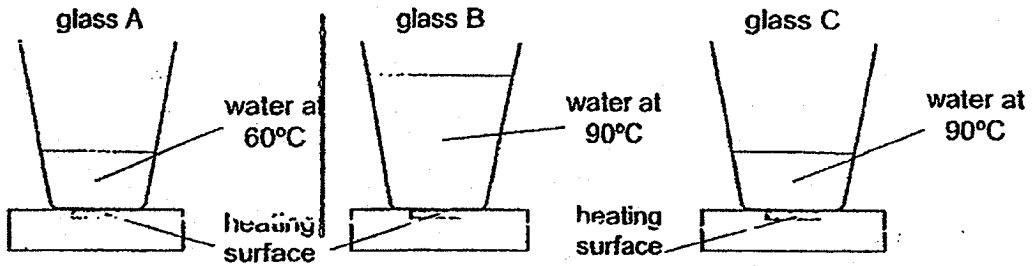

- (a) In which glass did the water take the longest time to reach the stated temperature? Explain your answer. [1]

---



---

In another experiment, another two identical glasses, P and Q, were filled with the same amount of water and placed on hotplates as shown below. The hotplates were the same except for their heating surfaces, which were of different shapes.

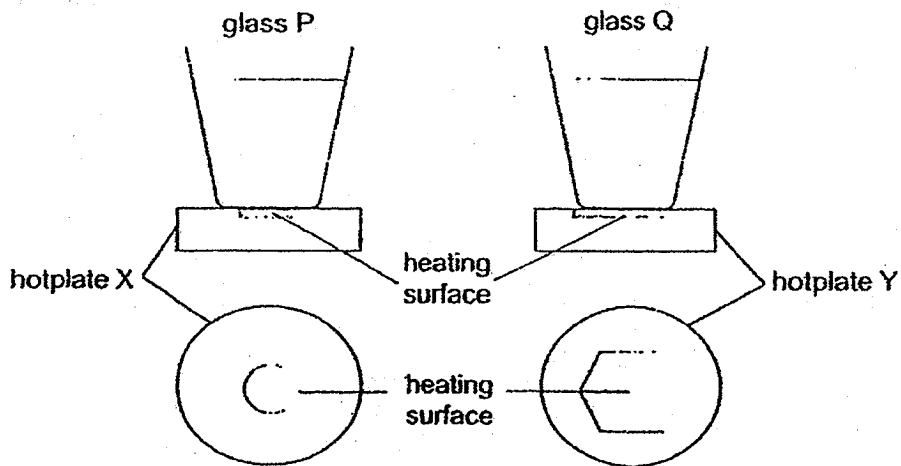

View of hot plates as seen from the top

- (b) In which glass would the water boil first? Explain why. [2]

---



---



---

(Go on to the next page)

|       |   |
|-------|---|
| SCORE |   |
|       | 3 |

During the day in a desert, a lizard was seen standing on the sand with its right fore-limb and left hind-limb raised in such a manner so that its body did not touch the hot sand.



- (c) Why did the lizard raise its body above the hot sand? [1]

---



---

After a few seconds, the lizard would switch to standing on the hot sand with its left fore-limb and right hind-limb raised instead, so that its body was again above the hot sand. The lizard switched between using its two different sets of limbs approximately every few seconds.

- (d) Why did the lizard switch between using its two different sets of limbs approximately every few seconds? [1]

---



---

(Go on to the next page)

|       |   |
|-------|---|
| SCORE | 2 |
|-------|---|



40 Jack carried out an experiment using a metal ball as shown in the diagram.

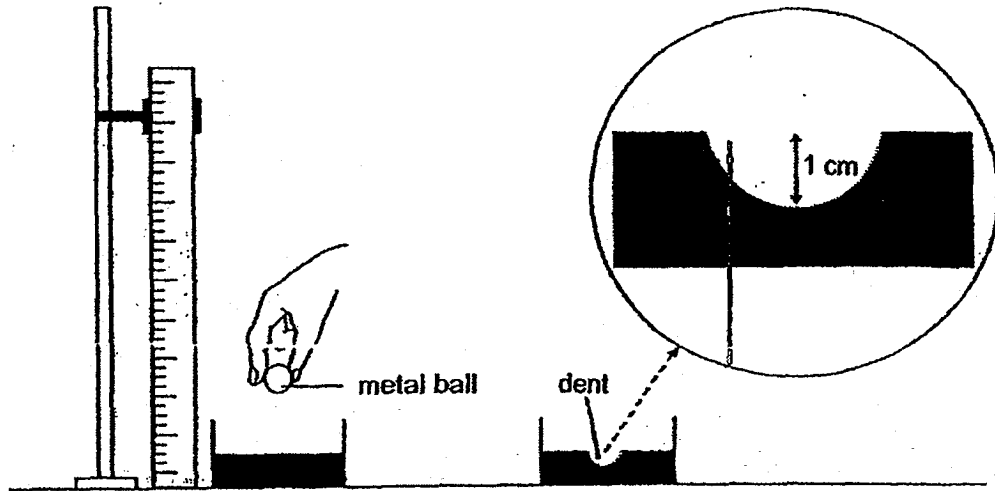

He released the ball from a height of 20 cm onto a container of sand. The ball created a dent in the sand which was 1 cm deep.

- (a) Jack released the metal ball from different heights. Based on his experiment, infer how the depth of the dent in the sand would change with the different heights he released the ball from. [1]

---



---

- (b) Give a reason for your answer in (a). [1]

---



---



---

- (c) A worker in a building construction site wears a helmet as shown. Explain how wearing a helmet protects his head from a falling object. [1]

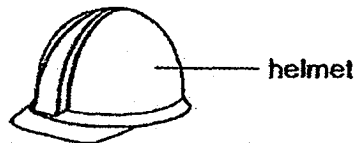

---



---



---

|       |   |
|-------|---|
| SCORE |   |
|       | 3 |

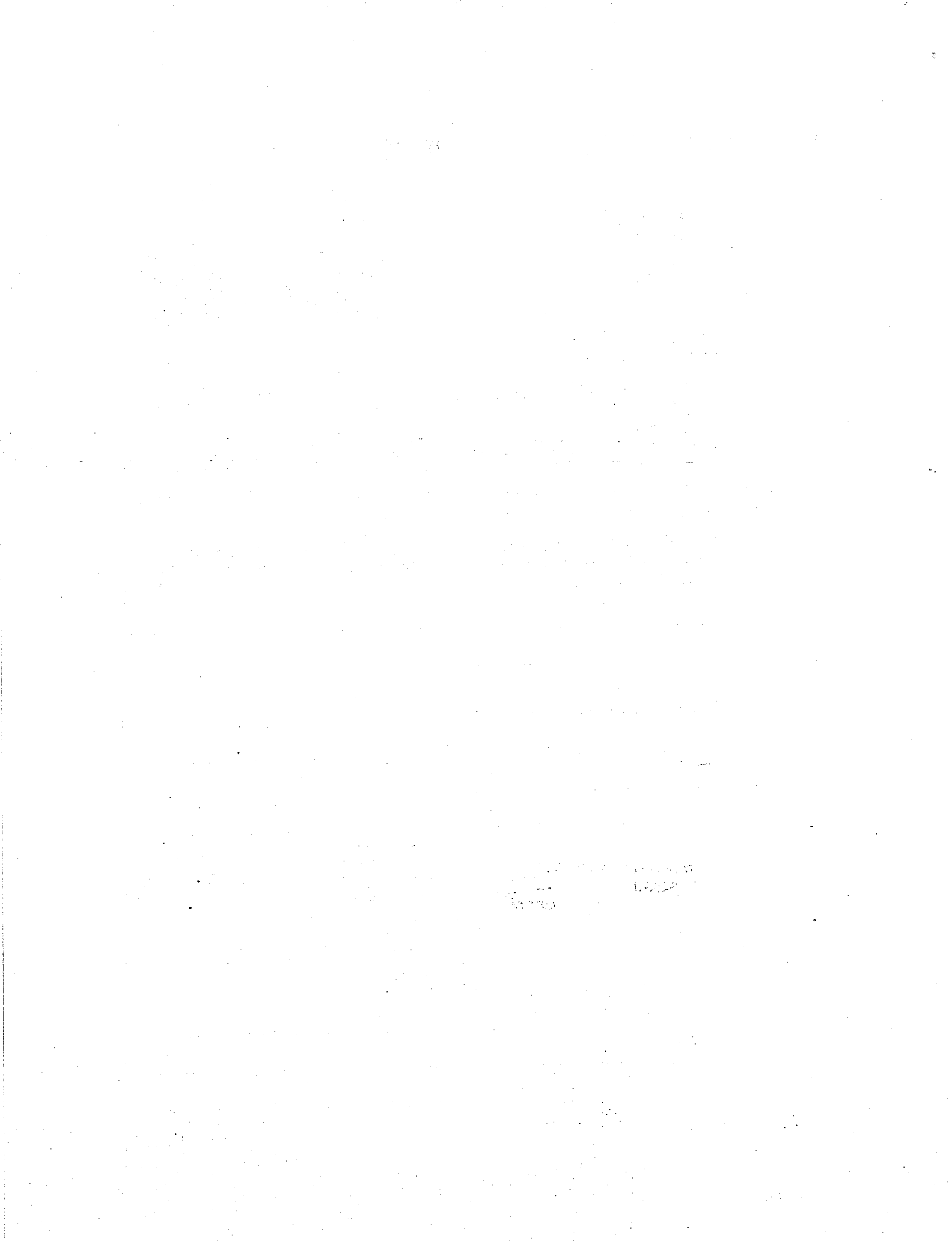

**EXAM PAPER 2018**

**LEVEL : PRIMARY 6**  
**SCHOOL : ANGLO-CHINESE SCHOOL (JUNIOR)**  
**SUBJECT : SCIENCE**  
**TERM : PRELIMINARY EXAM**

**BOOKLET A**

|            |            |            |            |            |            |            |            |            |            |
|------------|------------|------------|------------|------------|------------|------------|------------|------------|------------|
| <b>Q1</b>  | <b>Q2</b>  | <b>Q3</b>  | <b>Q4</b>  | <b>Q5</b>  | <b>Q6</b>  | <b>Q7</b>  | <b>Q8</b>  | <b>Q9</b>  | <b>Q10</b> |
| 3          | 1          | 4          | 4          | 4          | 2          | 4          | 2          | 1          | 1          |
| <b>Q11</b> | <b>Q12</b> | <b>Q13</b> | <b>Q14</b> | <b>Q15</b> | <b>Q16</b> | <b>Q17</b> | <b>Q18</b> | <b>Q19</b> | <b>Q20</b> |
| 4          | 2          | 8          | 2          | 2          | 4          | 2          | 3          | 3          | 1          |
| <b>Q21</b> | <b>Q22</b> | <b>Q23</b> | <b>Q24</b> | <b>Q25</b> | <b>Q26</b> | <b>Q27</b> | <b>Q28</b> |            |            |
| 1          | 4          | 4          | 2          | 4          | 3          | 1          | 3          |            |            |

**BOOKLET B**

- Q29.** (a) The canopy has to be waterproof for water droplets to not be absorbed by the canopy and instead roll off the canopy, thus the user will not become wet.  
 (b) Rubber is a poor conductor of electricity, unlike steel. Thus, the user will not be electrocuted if he is struck by lightning.  
 (c) It allows the user to look around him, thus he will be aware of his surroundings and not bump into anything.
- Q30.** (a) Shampoo has no definite shape.  
 (b) Air in the smaller bottle occupied the remaining space in the bottle and could not escape, preventing the shampoo from entering the bottle. Thus the shampoo overflowed even though the bottle was not full yet.  
 (c) She could lift the funnel slightly above the mouth of the smaller plastic bottle.
- Q31.** (a) Evaporation takes place at the surface of the liquid but boiling takes place throughout the liquid.  
OR  
 Evaporation can take place at any temperature while boiling can only take place at the boiling point.  
 (b). The water in the hot noodles gained heat from the hot noodles and evaporated into warm water vapour. The warm water vapour lost heat to the cooler inner portion of the cardboard cover and condensed to form water droplets.  
 (c) The hot noodles would continuously lose more heat to the cooler surrounding air, thus the hot noodles would cool down faster.
- Q32.** (a) Water, carbon dioxide, presence of both light and chlorophyll in the leaves.  
 (b) Water absorbed by the roots cannot be transported to the leaves at X due to the absence of water-carrying tubes, thus causing them to be unable to photosynthesise and hence wilt. At Y, the leaves were able to photosynthesise as water could be transported to them. As such, the leaves at Y could remain green.  
 (c) It will become smaller. Food produced in the leaves could not be transported to the roots, thus the roots would use up the food stored in Z for its survival. Since the amount of food stored decreases, the size of Z decreases.

- Q33. (a) Part G. At G, Mike's heart rate would be at 0 beats per minute, which is impossible as he still needs his heart to pump blood to the rest of his body.
- (b) As the intensity of his activities increased, his heart pumped more blood rich in oxygen at a faster rate to the rest of his body, thus respiration can take place at a faster rate and more energy is produced. At the same time, blood rich in carbon dioxide is pumped to the lungs and expelled at a faster rate, thus his heart rate increased.

Q34. (a)

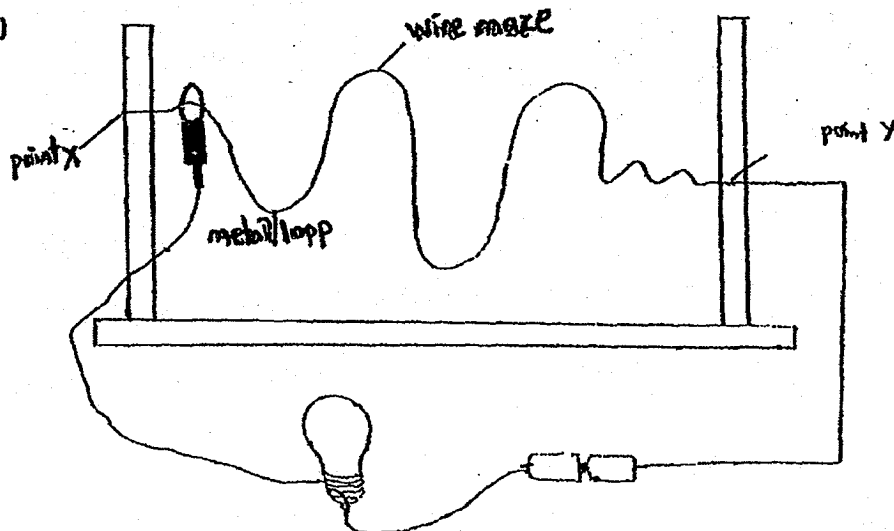

- (b) When the metal loop touched the wire maze, the circuit becomes closed and electricity can flow through the circuit, thus the bulb lights up.
- (c) The bulbs are arranged in series.
- (d) The wires were not properly connected to the bulbs.
- Q35. (a) To find out if the number of coils of wire around the iron rods affects the strength of the electromagnets.
- (b) He can measure the greatest distance at which each electromagnet can attract a steel clip. The stronger electromagnet is able to attract the steel clip at a greater distance compared to the weaker electromagnet.
- (c) Add more batteries to set-up Q.
- (d) If an electromagnet is used, the door can be locked and unlocked using a switch. However, if a permanent magnet were used, the door can only be locked.
- Q36. (a) R. The marble travelled the shortest distance, showing that the friction between surface R and the marble is the greatest and hence R is the roughest.
- (b) This is to reduce human error and obtain more reliable results.
- (c) The tiny bumps increase the friction between her feet and the floor, thus reducing the chances of her slipping and falling.

- Q37. (a) Add some vinegar into set-up B  
(b) The harmful gases present in the black smoke are soluble in rainwater and give a solution that is similar to vinegar. During the rainy season, since the rain that falls is similar to that of vinegar, it will cause the paint from the bodies of cars to come off.
- Q38. (a) Beetle P had its back tilted at a greater angle than that of beetle Q, thus the amount of exposed surface area to the wind is greater than that of beetle Q. More water vapour loses heat and condenses to form water droplets on the back of beetle P than that of beetle Q.  
(b) The bumps further increase the exposed surface area available for water vapour to lose heat and condense to form water droplets, thus enabling beetle P to obtain more water from the environment.
- Q39. (a) Glass B. It contained the most amount of water and was at a higher temperature, thus more heat is required to heat glass B and hence it takes the longest time to reach the stated temperature.  
(b) Glass Q. The heating surface of hotplate Y is larger than that of hotplate X, thus the water in glass Q gained heat at a faster rate than in glass P. Hence, the water in glass Q would boil first.  
(c) It is so as to reduce the amount of exposed surface area of the lizard's body to the hot sand, thus it gains heat at a slower rate and can survive the heat.  
(d) It allows one set of limbs to lose heat to the surrounding air and cool.
- Q40. (a) The higher the height from which the ball is released, the greater the depth of the dent in the sand.  
(b) At a higher height, the ball would have more gravitational potential energy which is converted to kinetic energy as the ball falls, thus more energy is transferred from the ball to the sand. Hence the ball has a greater force of impact and the depth of the dent increases.  
(c) Some of the kinetic energy possessed by the falling object is converted to heat and sound energy when it comes into contact with the helmet. Thus the kinetic energy possessed by the falling object and hence the force of the impact decreases.

