



CEDAR GIRLS' SECONDARY SCHOOL
PRELIMINARY EXAMINATION 2025
SECONDARY FOUR

CANDIDATE
NAME

CLASS

INDEX
NUMBER

ADDITIONAL MATHEMATICS

Paper 1

4049/01

25 August 2025

2 hours 15 minutes

Candidates answer on the Question Paper.

No Additional Materials are required.

READ THESE INSTRUCTIONS FIRST

Write your class, index number and name in the spaces at the top of this page.

Write in dark blue or black pen.

You may use an HB pencil for any diagrams or graphs.

Do not use staples, paper clips, highlighters, glue or correction fluid.

Answer **all** the questions.

Give non-exact numerical answers correct to 3 significant figures, or 1 decimal place in the case of angles in degrees, unless a different level of accuracy is specified in the question.

The use of an approved scientific calculator is expected, where appropriate.

You are reminded of the need for clear presentation in your answers.

The number of marks is given in brackets [] at the end of each question or part question.

The total number of marks for this paper is 90.

For Examiner's Use
90

This document consists of 21 printed pages and 1 blank page.

[Turn over]

Mathematical Formulae**1. ALGEBRA***Quadratic Equation*

For the equation $ax^2 + bx + c = 0$,

$$x = \frac{-b \pm \sqrt{b^2 - 4ac}}{2a}$$

Binomial expansion

$$(a + b)^n = a^n + \binom{n}{1} a^{n-1} b + \binom{n}{2} a^{n-2} b^2 + \dots + \binom{n}{r} a^{n-r} b^r + \dots + b^n,$$

where n is a positive integer and $\binom{n}{r} = \frac{n!}{r!(n-r)!} = \frac{n(n-1)\dots(n-r+1)}{r!}$

2. TRIGONOMETRY*Identities*

$$\sin^2 A + \cos^2 A = 1$$

$$\sec^2 A = 1 + \tan^2 A$$

$$\operatorname{cosec}^2 A = 1 + \cot^2 A$$

$$\sin(A \pm B) = \sin A \cos B \pm \cos A \sin B$$

$$\cos(A \pm B) = \cos A \cos B \mp \sin A \sin B$$

$$\tan(A \pm B) = \frac{\tan A \pm \tan B}{1 \mp \tan A \tan B}$$

$$\sin 2A = 2 \sin A \cos A$$

$$\cos 2A = \cos^2 A - \sin^2 A = 2 \cos^2 A - 1 = 1 - 2 \sin^2 A$$

$$\tan 2A = \frac{2 \tan A}{1 - \tan^2 A}$$

Formulae for ΔABC

$$\frac{a}{\sin A} = \frac{b}{\sin B} = \frac{c}{\sin C}$$

$$a^2 = b^2 + c^2 - 2bc \cos A$$

$$\Delta = \frac{1}{2} bc \sin A$$

Answer **all** the questions.

- 1 (a) Express $\frac{6\sqrt{2}-9}{\sqrt{2}-1}$ in the form of $a+b\sqrt{2}$, where a and b are integers.

[2]

- (b) $\frac{6\sqrt{2}-9}{\sqrt{2}-1}$ is a root of the equation $x^2 + px + q = 0$ where p and q are integers.

Using the result in **part (a)**, find the value of p and of q .

[4]

4

- 2 Find the range of values of the constant m for which the curve $y = (m-3)x^2 + mx + m$ lies completely above the x -axis. [5]

5

3 Express $\frac{2x^3 - 5}{x^2(x-1)}$ in partial fractions.

[6]

- 4 (a) State the range of principal values of $\tan^{-1} x$. [1]

- (b) The curve $y = a + b \cos cx$ is shown below for $0 \leq x \leq \frac{3\pi}{2}$ radians.

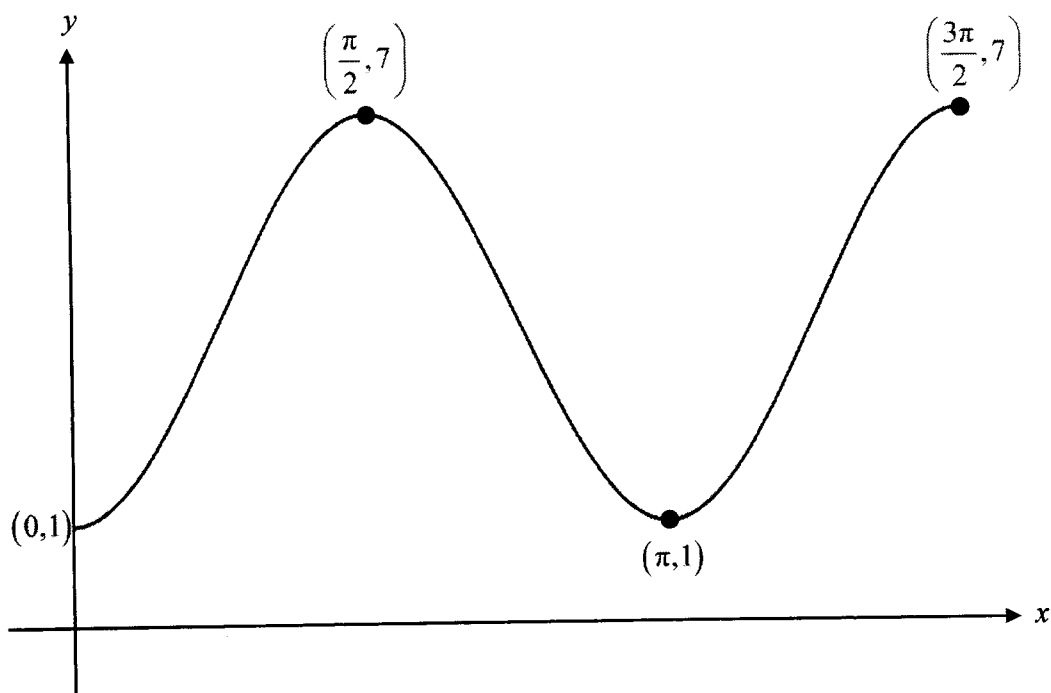

The curve has maximum points at $(\frac{\pi}{2}, 7)$ and $(\frac{3\pi}{2}, 7)$.

The curve also has minimum points at $(0, 1)$ and $(\pi, 1)$.

- (i) Find the values of a , b and c . [3]

7

- (ii) On the same axes, draw a straight line to determine the number of solutions for the equation $a\pi + b\pi \cos cx = 5\pi - 2x$ for $0 \leq x \leq \frac{3\pi}{2}$. [3]

8

- 5 When $f(x)$ is divided by $x-1$, the remainder is 61.
The remainder is -123 when $f(x)$ is divided by $x+3$.
Find the remainder when $f(x)$ is divided by $x^2 + 2x - 3$.

[5]

9

- 6 A curve is defined by the equation $y = \ln\left(\frac{e^x}{x^2 + 10}\right)$.

Show that the curve has no turning points for all real values of x .

[5]

10

- 7 Solutions to this question by accurate drawing will not be accepted.

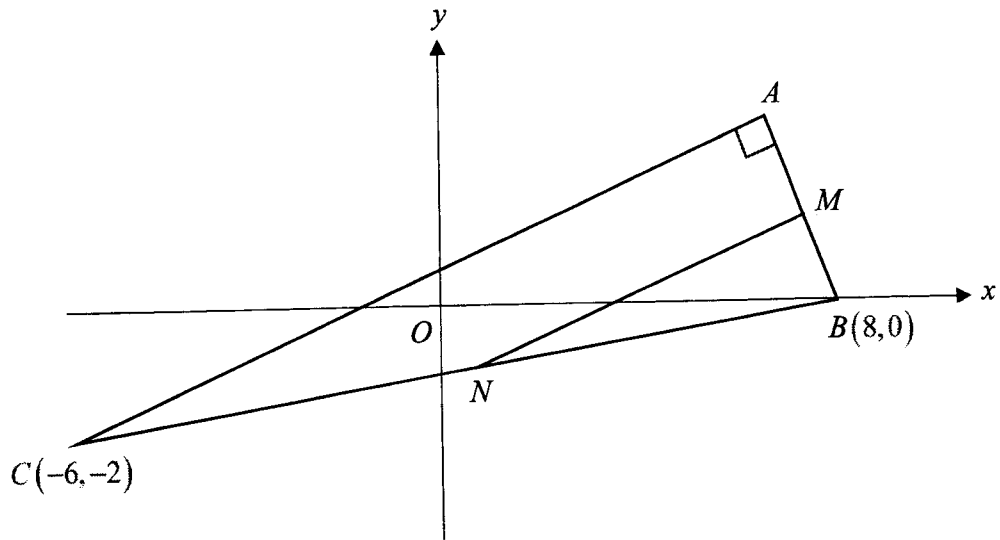

The diagram above shows a triangle ABC with vertices $B(7, 2)$ and $C(-6, -2)$.

AB is perpendicular to AC and is parallel to the line $y = -2x$.

M and N are the mid-points of AB and BC respectively.

- (a) Find the coordinates of A .

[6]

11

(b) Explain why the quadrilateral $ACNM$ is a trapezium. [1]

(c) Find the area of the quadrilateral $ACNM$. [3]

12

- 8 An architect uses 40 cm of wire to design 2 window frames for a room model. He wants as much light as possible to pass through the windows for his design. One frame is to be an equilateral triangle of side x cm. The other is to be a semi-circle of radius r cm.

- (a) Show that the total area, A cm², enclosed by the two window frames is given by

$$A = \frac{\pi(40-3x)^2}{2(\pi+2)^2} + \frac{\sqrt{3}x^2}{4}. \quad [4]$$

13

- (b) Given that x can vary, find the stationary value of A . [4]

- (c) Find the nature of this stationary value and explain why the architect may not be happy with his design. [2]

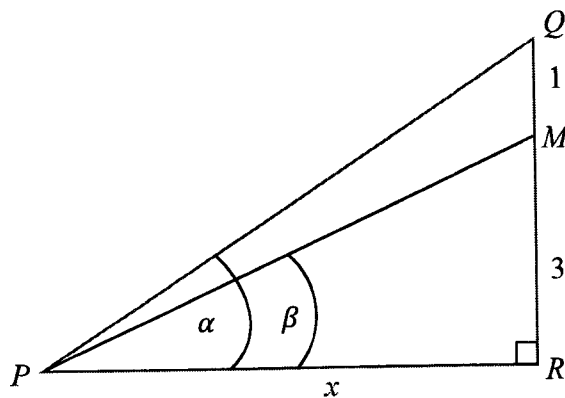

The diagram shows a triangle PQR .

Point M lies on QR such that $QM = 1$ unit and $MR = 3$ units.

Angle $PRQ = 90^\circ$ and PR is x units. Angles QPR and MPR are denoted by α and β respectively as shown, where $0^\circ < \alpha < 45^\circ$.

Given $\tan(\alpha - \beta) = \frac{1}{8}$, find the value of x . [5]

15

- 10 Solve the equation $\log_4 x - \frac{3}{\log_x 8} = (\log_2 x)^2$, leaving your answer in terms of $\sqrt{2}$.

[5]

16

11 (a) Prove that $\frac{\tan x}{1+\sec x} + \frac{1+\sec x}{\tan x} = 2 \operatorname{cosec} x$. [4]

(b) Hence, solve $\frac{\tan 2x}{1 + \sec 2x} + \frac{1 + \sec 2x}{\tan 2x} = 3 \sec x$ for $-\pi \leq x \leq \pi$. [4]

(c) Use the result in **part (a)** to find the range of values of k for which the equation

$$\frac{\tan x}{1 + \sec x} + \frac{1 + \sec x}{\tan x} = k \text{ has no solutions.} \quad [2]$$

18

12 (a) Given that $y = e^x (1 + \cos x)$, show $\frac{dy}{dx} = e^x (1 + \cos x - \sin x)$. [1]

(b) Hence find $\int e^x (\cos x - \sin x) dx$. [3]

19

- 13 A circular patch of water of negligible thickness is evaporating. The radius of the patch, r cm is decreasing at a constant rate of 0.2 cm/s. Find the rate of change of the area of this patch, A cm² when the area of the patch is 225π cm². [5]

20

- 14 In the figure below, points A , B and C lie on the circle. AC is a diameter of a circle with centre O .

The tangent to the circle at X meets AC produced at Y .

Chord XB intersects AC at F .

XC bisects the angle of YXB .

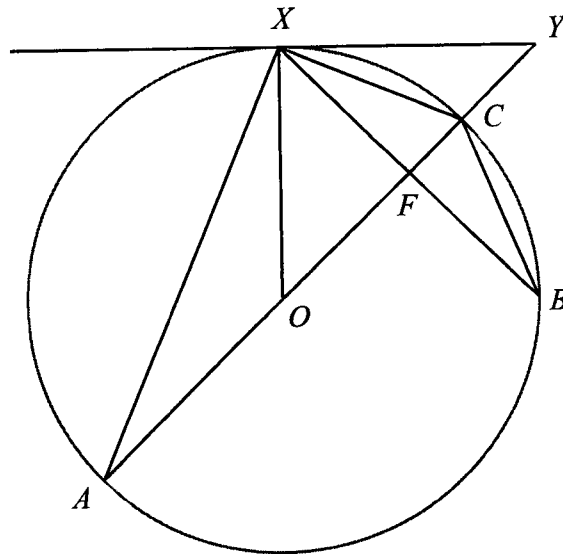

- (a) Prove that $CX = CB$.

[2]

- (b) Prove that triangle AXC is similar to triangle BFC . [3]

- (c) Hence, prove that $AC \times FC = BC^2$. [2]

End of Paper

BLANK PAGE



CEDAR GIRLS' SECONDARY SCHOOL
PRELIMINARY EXAMINATION 2025
SECONDARY FOUR

CANDIDATE
NAME

CLASS

INDEX
NUMBER

ADDITIONAL MATHEMATICS

Paper 2

4049/02

28 August 2025

2 hours 15 minutes

Candidates answer on the Question Paper.

No Additional Materials are required

READ THESE INSTRUCTIONS FIRST

Write your class, index number and name in the spaces at the top of this page.

Write in dark blue or black pen.

You may use an HB pencil for any diagrams or graphs.

Do not use staples, paper clips, highlighters, glue or correction fluid.

Answer **all** the questions.

Give non-exact numerical answers correct to 3 significant figures, or 1 decimal place in the case of angles in degrees, unless a different level of accuracy is specified in the question.

The use of an approved scientific calculator is expected, where appropriate.

You are reminded of the need for clear presentation in your answers.

The number of marks is given in brackets [] at the end of each question or part question.

The total number of marks for this paper is 90.

For Examiner's Use
90

This document consists of **18** printed pages.

[Turn over]

Mathematical Formulae**1. ALGEBRA***Quadratic Equation*

For the equation $ax^2 + bx + c = 0$,

$$x = \frac{-b \pm \sqrt{b^2 - 4ac}}{2a}$$

Binomial expansion

$$(a + b)^n = a^n + \binom{n}{1} a^{n-1} b + \binom{n}{2} a^{n-2} b^2 + \dots + \binom{n}{r} a^{n-r} b^r + \dots + b^n,$$

where n is a positive integer and $\binom{n}{r} = \frac{n!}{r!(n-r)!} = \frac{n(n-1) \dots (n-r+1)}{r!}$

2. TRIGONOMETRY*Identities*

$$\sin^2 A + \cos^2 A = 1$$

$$\sec^2 A = 1 + \tan^2 A$$

$$\operatorname{cosec}^2 A = 1 + \cot^2 A$$

$$\sin(A \pm B) = \sin A \cos B \pm \cos A \sin B$$

$$\cos(A \pm B) = \cos A \cos B \mp \sin A \sin B$$

$$\tan(A \pm B) = \frac{\tan A \pm \tan B}{1 \mp \tan A \tan B}$$

$$\sin 2A = 2 \sin A \cos A$$

$$\cos 2A = \cos^2 A - \sin^2 A = 2 \cos^2 A - 1 = 1 - 2 \sin^2 A$$

$$\tan 2A = \frac{2 \tan A}{1 - \tan^2 A}$$

Formulae for ΔABC

$$\frac{a}{\sin A} = \frac{b}{\sin B} = \frac{c}{\sin C}$$

$$a^2 = b^2 + c^2 - 2bc \cos A$$

$$\Delta = \frac{1}{2} bc \sin A$$

3

Answer **all** the questions.

- 1 An object was launched from a machine. Its height, y metres above ground, t seconds after launch, can be modelled by a quadratic function $y = f(t)$. Four seconds after launch, the object reached its maximum height of 81 m and then dropped to a height of 54 m after a further three seconds.

(a) Find the initial height of the object when it was launched. [4]

(b) Without solving a quadratic equation, explain and determine how long did the object stay above 54 m? [2]

4

- 2 Show that the solution of the equation $12^{x+1} = 36 \times 4^{x+2}$ can be expressed as $1 + \frac{\lg a}{\lg b}$,
where a and b are integers. [5]

5

- 3 (a) Solve the equation $3x^3 - 11x^2 + 3x + 2 = 0$, expressing non-integer roots in surd form. [5]

- (b) Hence, solve the equation $x^3 + 11x^2 + 9x - 18 = 0$, expressing non-integer roots in surd form. [2]

6

- 4 A curve is such that $\frac{d^2y}{dx^2} = \frac{12}{(3-2x)^2}$. Given that the curve passes through the points $\left(\frac{1}{2}, 1\right)$ and $(1, \ln(8e^2))$, show that the y -intercept of the curve can be expressed as $a \ln\left(\frac{b}{c}\right)$ where a , b and c are constants. [8]

7

5 A tangent to a circle at the point $(4, 3)$ intersects the x -axis at $x = 7$. The line with the equation $3y = 2x + 6$ is normal to the circle at another point.

(a) Find the equation of the circle. [8]

(b) Find, in exact form, the equations of the tangents to the circle that are parallel to the x -axis. [2]

8

- 6 A particle, P , starts moving in a straight line with a velocity of 8 m/s at a displacement of 3 m from a fixed point O . The velocity, v m/s of the particle t seconds after moving is given by $v = 5 \cos t + 2 \sin t + c$.

(a) Find the value of c . [2]

(b) Find the initial acceleration of the particle. [2]

9

- (c) By explaining with relevant working, show the particle changed its direction of motion during the 3rd second. [3]

- (d) Find displacement of P from O at $t = 6$. [3]

- 7 It is given that there is a term in x^2 in the expansion of $\left(\sqrt{x} - \frac{2}{x}\right)^n$, where n is a positive integer.
- (a) Find the smallest possible value of n , explaining your answer. [4]

- (b) In the case where $n = 7$, show that there is no constant term in the expansion of $\left(\frac{48}{x^2} - x^4\right)\left(\sqrt{x} - \frac{2}{x}\right)^n$. [5]

12

- 8 The temperature, $\theta^{\circ}\text{C}$, of a cup of hot chocolate milk, as it cools to room temperature, can be modelled by the formula $\theta = 27 + qb^{-t}$, where q and b are constants and t is the time of cooling in minutes. Measurements of t and θ are shown in the table below.

t	2	4	6	8	10	12
θ	71	59	48	43	38	35

- (a) Explain how a straight line graph can be drawn to represent the formula and draw it for the given data. [4]

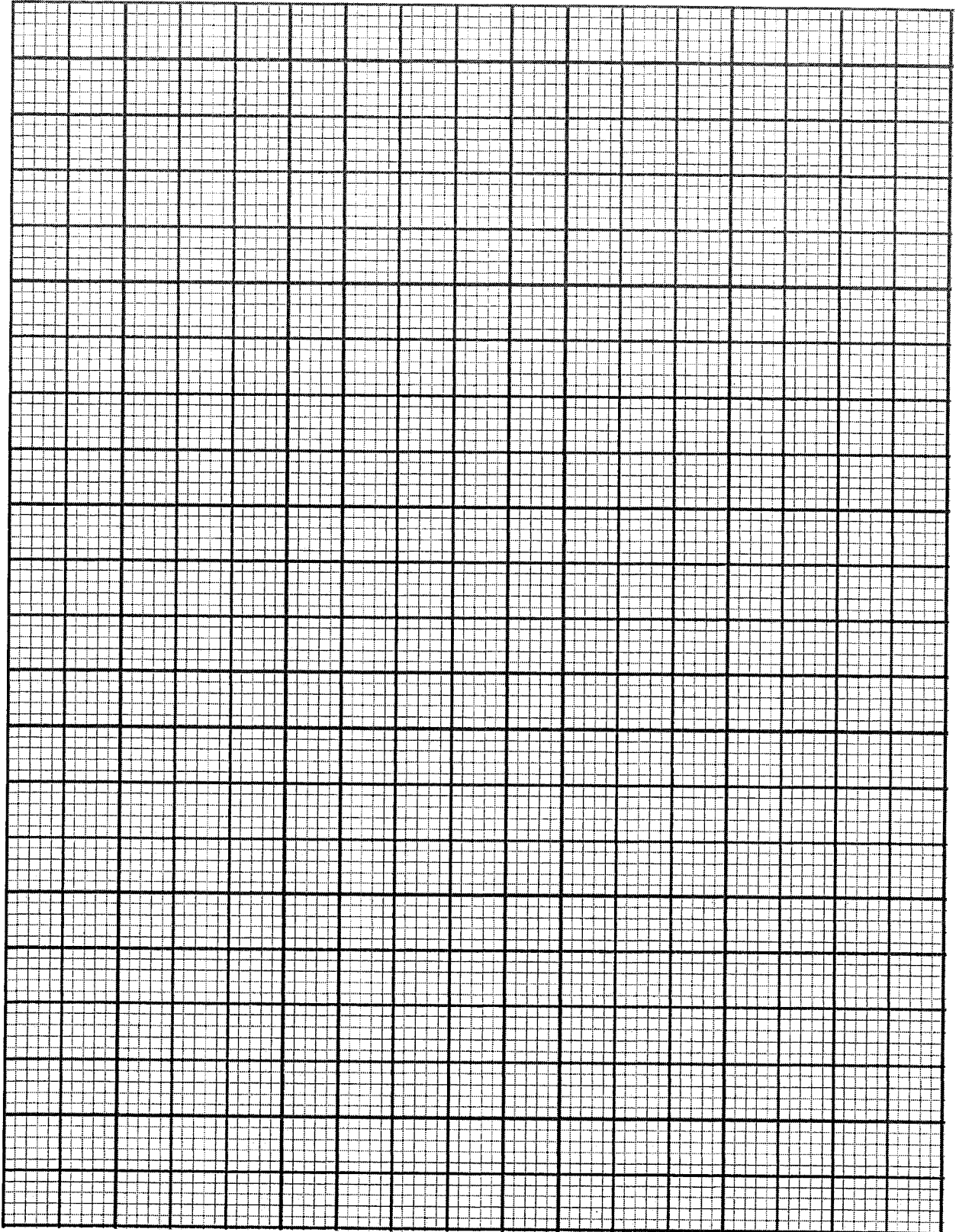

14

(b) Estimate the value of q and of b . [3]

(c) Use your graph to estimate the temperature of the cup of tea at $t = 7$. [2]

(d) What is the room temperature? Explain how you obtain your answer. [2]

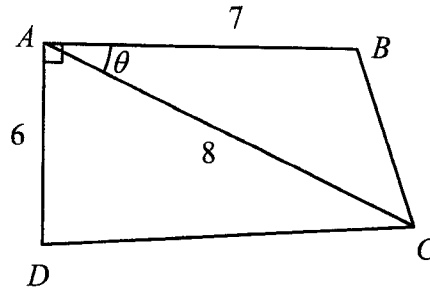

A farmer owns two triangular plots of land ABC and ADC as shown in the diagram above. It is given that $AB = 7$ m, $AC = 8$ m and $AD = 6$ m, angle BAD is a right angle and angle $BAC = \theta$ radians.

- (a) (i) Show the total area of the two plots of land, A m², can be expressed in the form $a \sin \theta + b \cos \theta$, where a and b are integers. [3]

- (ii) Express A in the form $R \sin(\theta + \alpha)$, where $R > 0$ and $0 < \alpha < \frac{\pi}{2}$. [3]

16

- (iii) Find the greatest possible value of A and the value of θ at which this occurs. [3]

- (b) The farmer would like to grow roses on plot ABC and hibiscus on plot ADC . Given that he wants the area of plot ABC to be twice the area of plot ADC , find the value of θ . [3]

10

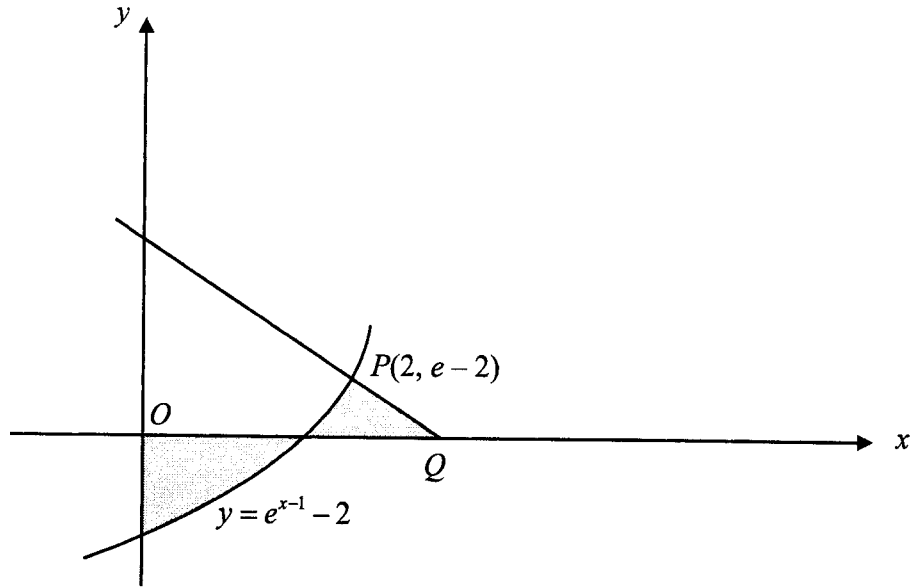

The diagram shows part of the curve $y = e^{x-1} - 2$. The point $P(2, e-2)$ lies on the curve and the normal to the curve at P meets the x -axis at Q .

- (a) Find the x -coordinate of Q in terms of e .

[5]

18

(b) Find the total area of the shaded region.

[7]

End of Paper