

Name: _____ ()

Class: Primary 5 _____

CHIJ ST NICHOLAS GIRLS' SCHOOL.

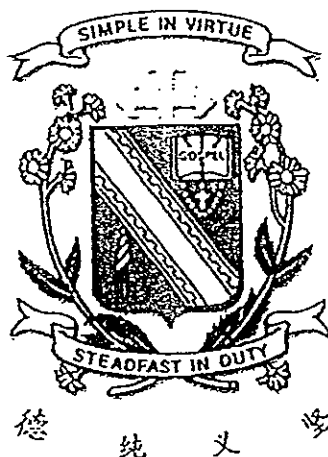

Primary 5
Continual Assessment 2 – 2012
SCIENCE
BOOKLET A

27 August 2012

Total Time for Booklets A and B: 1 hour 45 minutes

30 questions
60 marks

Do not open this booklet until you are told to do so.
Follow all instructions carefully.
Answer all questions.

This booklet consists of 20 printed pages.



Section A : (30 x 2 MARKS)

For each question from 1 to 30, four options are given. One of them is the correct answer. Make your choice (1, 2, 3 or 4). Shade the correct oval (1, 2, 3 or 4) on the Optical Answer Sheet.

1. The diagram below shows the development of an animal over two months.

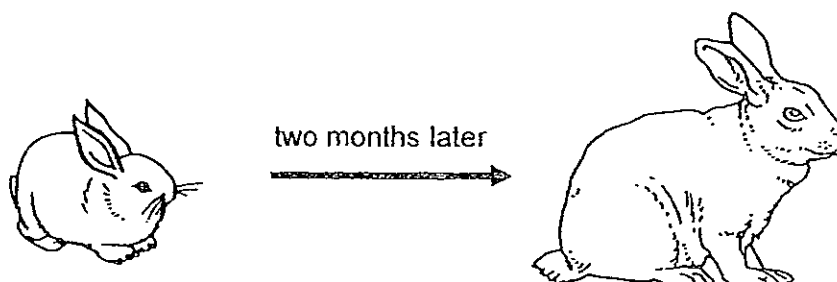

(Based on the diagram above), which one of the following conclusions can be made?

- (1) The animal has grown.
 - (2) The animal feeds on plants only.
 - (3) The animal grows longer legs to jump higher.
 - (4) The animal can only respond to changes after two months.
2. Three organisms S, T, and U were observed over a period of time. Their characteristics were recorded in the table below.

Characteristics	Organisms		
	S	T	U
Able to move freely from place to place	No	Yes	No
Able to reproduce	Yes	Yes	Yes
Able to respond to stimulus	Yes	Yes	Yes
Able to make its own food	Yes	No	No

Which one of the following identifies organisms S, T and U correctly?

	S	T	U
(1)	Fungi	Animal	Plant
(2)	Plant	Animal	Fungi
(3)	Bacteria	Fungi	Plant
(4)	Plant	Bacteria	Animal

3. The classification chart below shows how some animals are grouped.

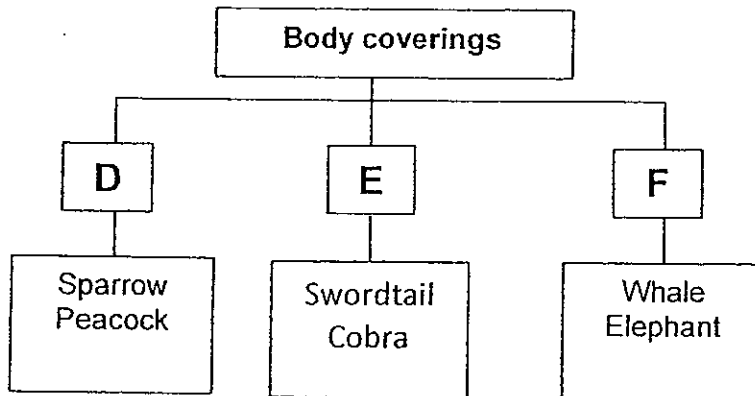

Which one of the following represents headings D, E and F correctly?

	D	E	F
(1)	Feathers	Scales	Skin
(2)	Skin	Hard covering	Hair
(3)	Hair	Skin	Hard covering
(4)	Feathers	Scales	Hair

4. Joan notices that the papaya plant in her garden does not bear fruits although it has flowered a few times. What could be the reason for this?

- A Pollination has not occurred
- B The flowers has only male parts
- C The flowers has only female parts
- D The plant is not mature enough to bear fruits

- (1) A only
- (2) B and C only
- (3) A and B only
- (4) A, B, C and D

5. The diagrams below show two plants and their leaves

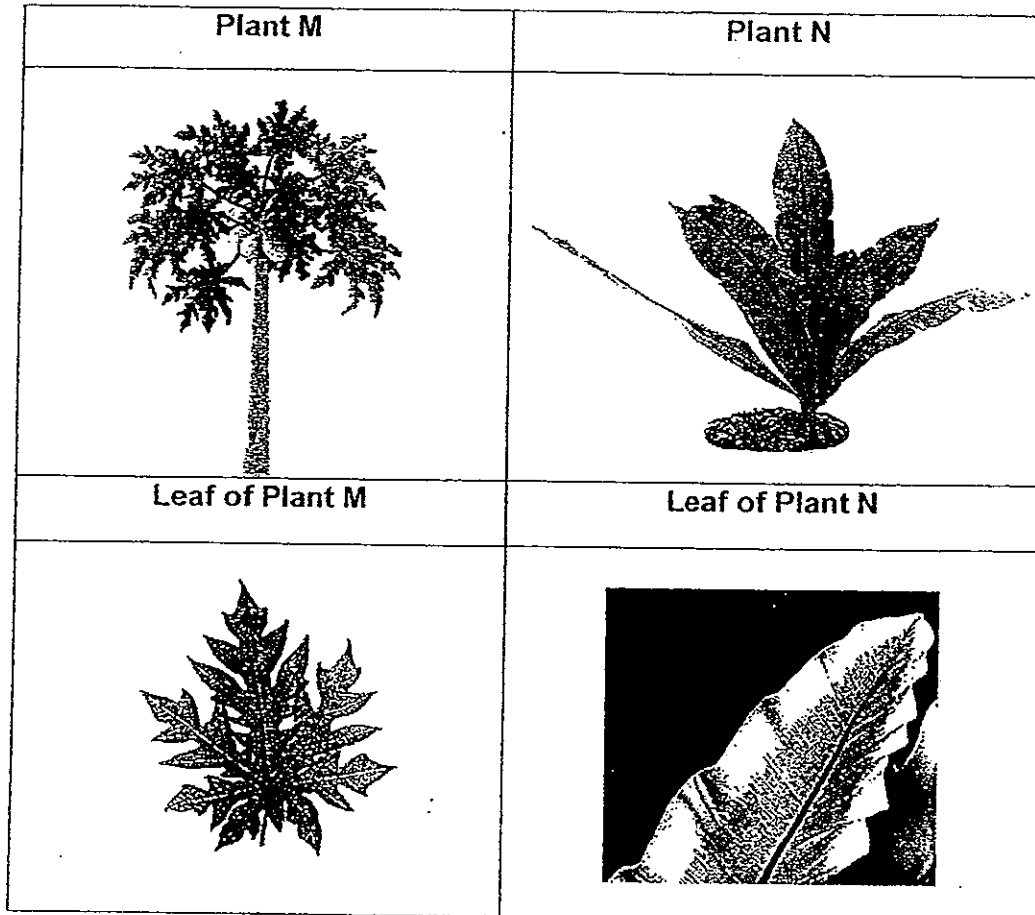

Which one of the following differences can be observed between plants M and N?

	Differences	
	Plant M	Plant N
(1)	It reproduces by fruits	It reproduces by seeds
(2)	It reproduces by seeds	It reproduces by spores
(3)	It has lobed-edge leaves	It has jagged-edge leaves
(4)	It needs light	It does not need light

6. Jason made an observation of three animals A, B and C. His observations are recorded in the table shown below.

Observations	Animal A	Animal B	Animal C
Have 4 legs	✓		
Have lungs	✓	✓	
Lay eggs		✓	✓
Have wings		✓	✓
Have breathing holes			✓

Which one of the following identifies animals A, B and C correctly?

	Animal A	Animal B	Animal C
(1)	Bat	Duck	Grasshopper
(2)	Dog	Hen	Butterfly
(3)	Cat	Grasshopper	Duck
(4)	Grasshopper	Duck	Bat

7. The classification table below shows the human body systems.

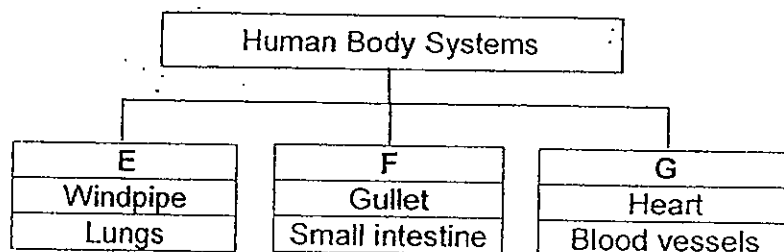

Which one of the following identifies headings E, F and G correctly?

	E	F	G
(1)	Respiratory System	Digestive System	Muscular System
(2)	Circulatory System	Respiratory System	Digestive System
(3)	Respiratory System	Digestive System	Circulatory System
(4)	Circulatory System	Digestive System	Respiratory System

8. The diagram below shows a part of a plant.

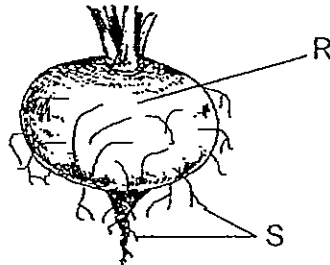

Which one of the following states the functions of parts R and S correctly?

	R	S
(1)	Makes food for the plant	Absorbs water and mineral salts
(2)	Stores excess food and water	Absorbs water and mineral salts
(3)	Absorbs water	Absorbs mineral salts
(4)	Absorbs mineral salts	Absorbs water

9. The following are parts of the human digestive system.

- A Gullet
- B Stomach
- C Mouth
- D Large intestine
- E Small intestine

Which one of the following correctly identifies their functions?

	Produce digestive juices	Absorb nutrients
(1)	B, D, E	B, D, E
(2)	A, B, C, D, E	B
(3)	B, E	D, E
(4)	B, C, E	E

10. Martha wanted to find out how the amount of soil would affect the germination of some seeds. Below are some of the set-ups she could use.

Set-up	Number of seeds	Amount of soil	Amount of water	Presence of light	Temperature
E	4	1000g	50ml	Yes	29°C
F	6	500g	200ml	Yes	32°C
G	6	1000g	100ml	No	32°C
H	4	500g	50ml	Yes	29°C

Which of the above set-ups should she use for her experiment?

- (1) E and F only
 - (2) G and H only
 - (3) F and G only
 - (4) E and H only
11. The bar graph below shows the number of days in each stage of the life cycle of insects C and D.

Number of days

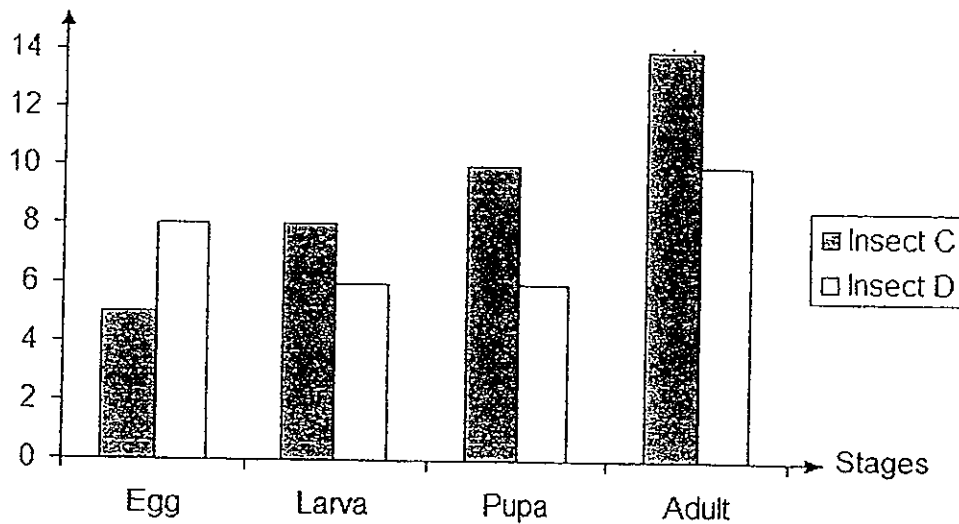

How many days do insects C and D take to grow from the egg stage to the adult stage?

	Insect C	Insect D
(1)	37 days	30 days
(2)	23 days	20 days
(3)	18 days	12 days
(4)	13 days	14 days

12 Study the concept cartoon shown below about the systems in living things.

Our heart pumps more blood through the circulatory system when we do strenuous exercises.

Annie

The respiratory system needs digested food from the digestive system to get energy.

Bob

The digestive system produces carbon dioxide which is carried away by the blood.

Charles

Our circulatory system transports digested food and oxygen to all parts of the body.

Deanne

Who has/have made the correct statements?

- (1) Annie only
- (2) Annie and Deanne only
- (3) Charles and Deanne only
- (4) Annie, Bob, Charles and Deanne

13. The diagram below represents the circulation of blood in a fish and a man.

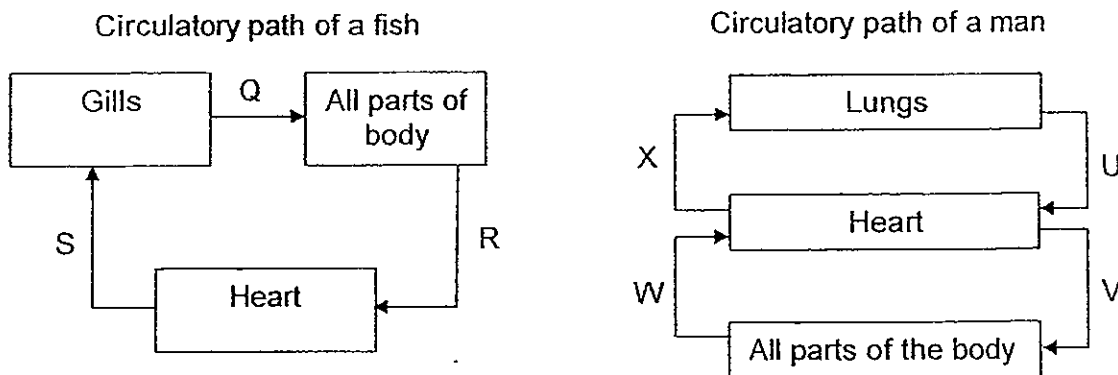

Which part of the circulatory paths in the fish and the man carry oxygenated blood?

	Fish	Man
(1)	Q	U and V
(2)	Q and R	U and V
(3)	R and S	U and X
(4)	Q, R and S	W and V

14. Study the flowchart below carefully.

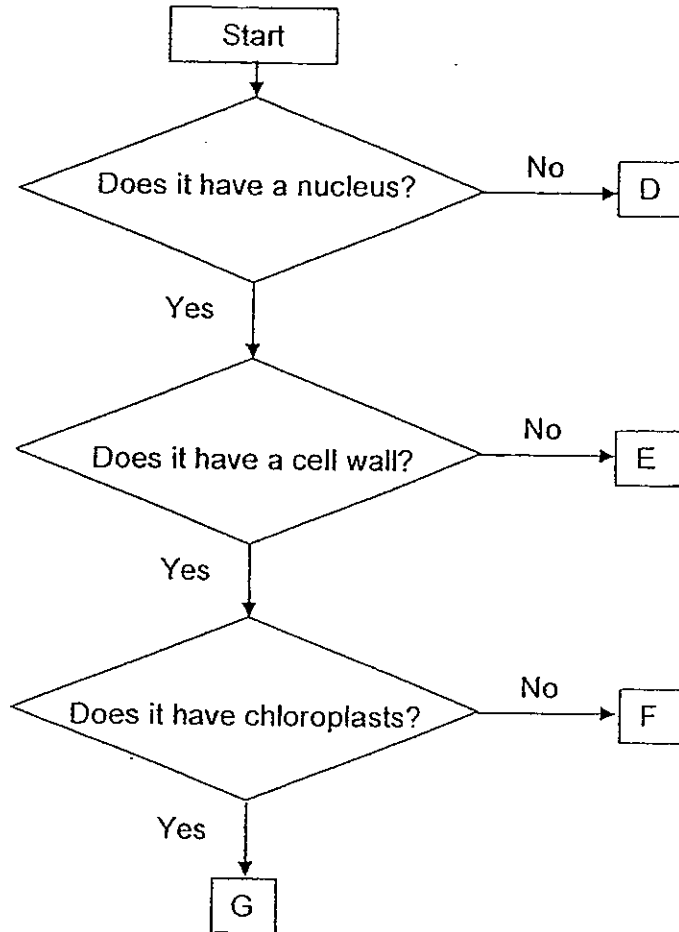

Which one of the following best represents the letters D, E, F and G in the flowchart above?

	D	E	F	G
(1)	Red blood cell	Onion cell	Cheek cell	Leaf cell
(2)	Cheek cell	Red blood cell	Root cell	Onion cell
(3)	Red blood cell	Cheek cell	Root cell	Leaf cell
(4)	Onion cell	Root cell	Leaf cell	Red blood cell

15. The diagram below shows how fruits are developed.

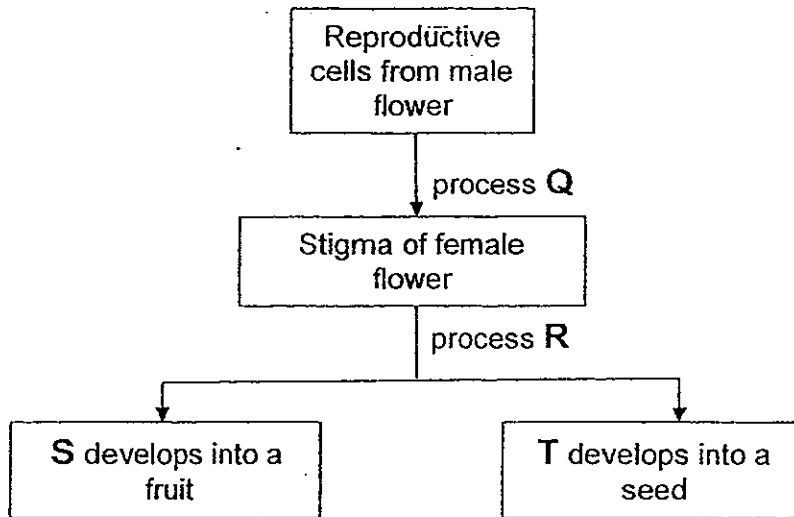

Which one of the following identifies Q, R, S and T correctly?

	Processes		Parts of the flower	
	Q	R	S	T
(1)	Pollination	Fertilisation	Ovary	Ovule
(2)	Fertilisation	Pollination	Ovule	Ovary
(3)	Germination	Fertilisation	Ovary	Ovule
(4)	Pollination	Germination	Ovule	Ovary

16. The table below shows the results of several tests done on three materials A, B and C.

Tests	Materials		
	A	B	C
Can it be bent easily?	No	Yes	No
Can it be stretched?	No	Yes	No
Is it waterproof?	Yes	Yes	Yes
Does it break easily when dropped?	Yes	No	No

Which one of the following best represents what materials A, B and C are?

	A	B	C
(1)	Wood	Plastic	Ceramic
(2)	Glass	Styrofoam	Paper
(3)	Porcelain	Leather	Fabric
(4)	Clay	Rubber	Metal

17. An experiment was conducted to compare the hardness of four rods, J, K, L and M, by scratching them on blocks made of wood, metal and glass. The results were recorded in the table below. A tick (✓) indicates the presence of scratch marks on the objects.

Rods used to scratch	Presence of scratch marks observed on blocks made of		
	Wood	Metal	Glass
J	✓		
K	✓	✓	✓
L			
M	✓		✓

Which one of the following correctly shows the hardness of the four rods starting with the least hard to the hardest?

	Hardness			
	least			Most
(1)	L	M	J	K
(2)	K	J	M	L
(3)	L	J	M	K
(4)	K	M	J	L

18. Diagram 1 shows a fish tank filled with 1000cm^3 of water. Two small fish of similar size were first put in the tank as shown in diagram 2. Then one fish was replaced with a bigger fish as shown in diagram 3. The changes in the volume of the content of the tank are shown below.

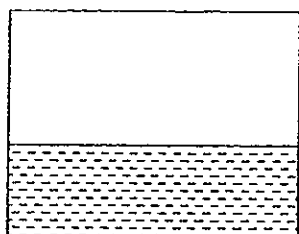

1000cm^3
Diagram 1

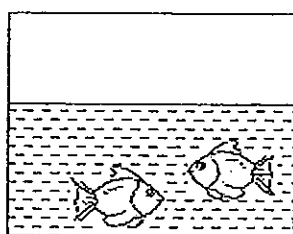

1200cm^3
Diagram 2

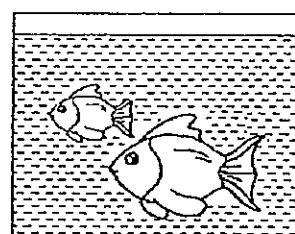

2000cm^3
Diagram 3

From the experiment above, what is the volume of the small fish and the big fish respectively?

	Volume	
	A small fish	A big fish
(1)	100cm^3	900cm^3
(2)	100cm^3	800cm^3
(3)	200cm^3	800cm^3
(4)	200cm^3	1800cm^3

19 The flowchart below is used to identify what U, V and W are.

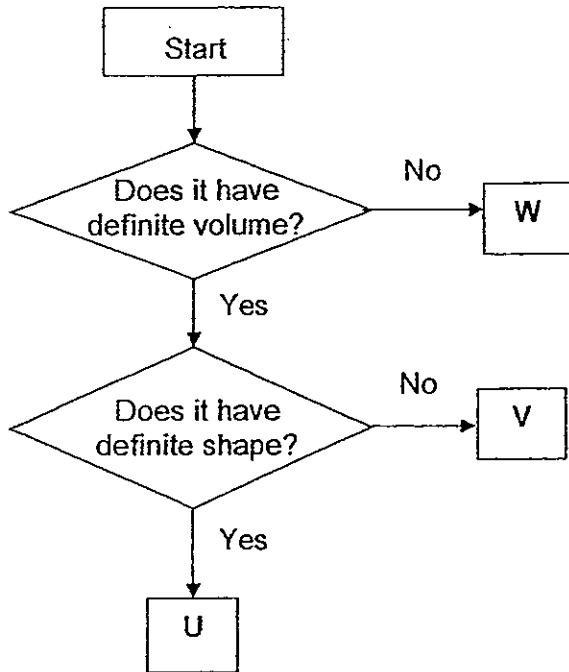

Based on the flowchart above, which one of the following is correctly represented by U, V and W?

	U	V	W
(1)	ice	rain	mist
(2)	ice	mist	cloud
(3)	snow	cloud	steam
(4)	cloud	snow	water vapour

20 The diagram below shows a compass seen from two different angles.

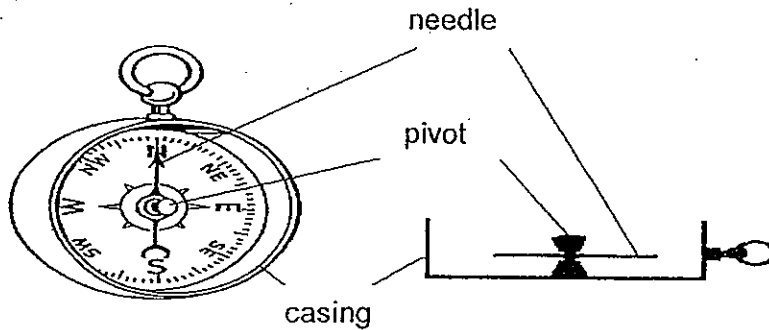

Which one of the following are possible materials for making the different parts of the compass?

	Pivot	Needle	Casing
(1)	aluminium	steel	wood
(2)	cobalt	iron	aluminium
(3)	steel	iron	nickel
(4)	iron	nickel	steel

21. Diana had four magnets L, M, N and O as shown below.

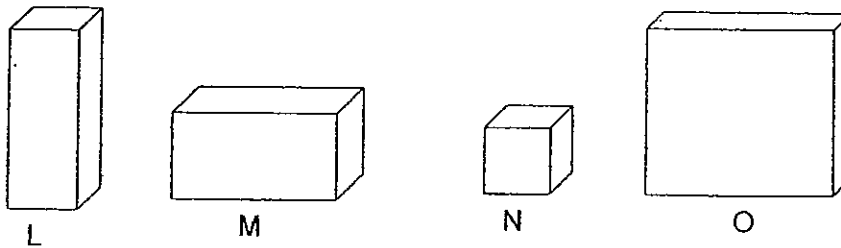

She placed the magnets near a pile of staples and recorded her observation in the table below.

Magnet	Distance between magnets and staples (cm)	Number of staples attracted
L	2	12
M	5	11
N	6	12
O	2	11

Which one of the following statements about the magnets is correct?

- (1) Magnet L is stronger than magnet M.
- (2) Magnet N has the strongest magnetic strength.
- (3) The bigger the magnet, the stronger the magnetism.
- (4) Magnet M and magnet O have the same magnetic strength.

22. The diagram below shows a sharp bend along a two-way road.

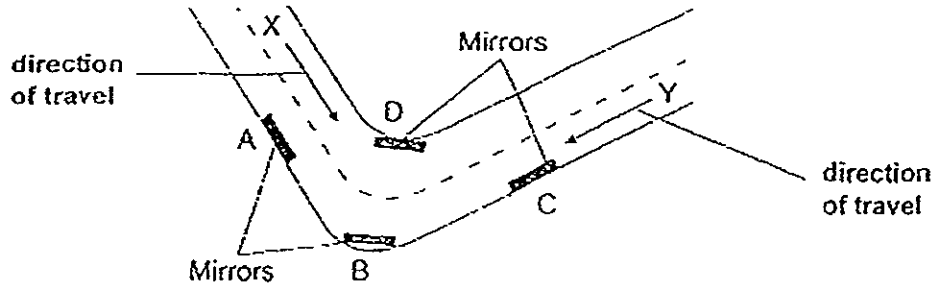

Which mirror(s) A, B, C, D will enable motorists at X and Y to see each other before they meet?

- (1) A only
- (2) B only
- (3) B and D only
- (4) A, B, C and D

23. The diagram below shows the processes, A, B, C and D, that have to take place as water changes its states.

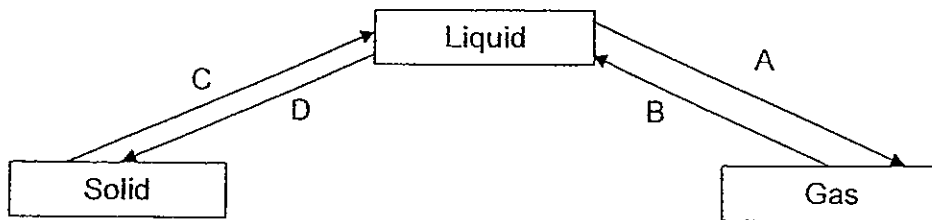

Which one of the following shows the letters representing each of the processes in the table below correctly?

	Processes			
	Evaporation	Melting	Condensation	Freezing
(1)	A	D	C	D
(2)	B	A	D	C
(3)	A	C	B	D
(4)	C	B	A	C

24. Mrs Ang conducted an experiment with a datalogger and four objects, E, F, G and H, of the same size but made of different materials. She placed each object in between the light source and the datalogger one at a time and recorded the amount of light passing through the object as shown below.

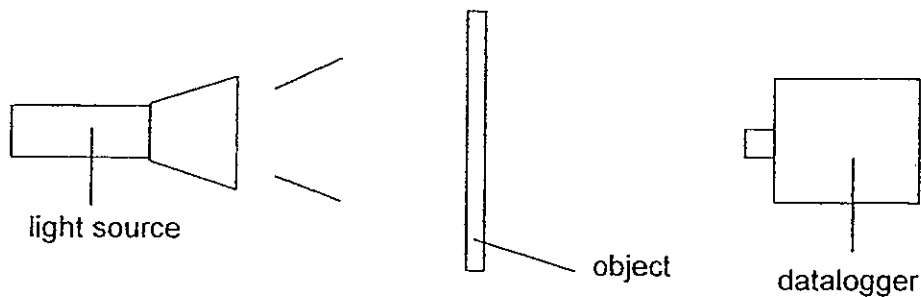



The amount of light passing through each type of object is recorded in the table below. The amount of light without any object placed in between the light source and the datalogger is 4500 lux (unit for the amount of light).

Object	E	F	G	H
Amount of light in lux	3700	0	2200	4400

Which one of the following best represents the objects E, F, G and H?

	Object E	Object F	Object G	Object H
(1)	Sunglasses	Clear glass	Tracing paper	Cardboard
(2)	Tracing paper	Cardboard	Sunglasses	Clear glass
(3)	Tracing paper	Clear glass	Sunglasses	Cardboard
(4)	Sunglasses	Cardboard	Tracing paper	Clear glass

25. The table below shows the expansion of certain metallic materials, J, K and L, when heated at 100°C.

Key	Material	Length of material at room temperature	Length of material at 100°C
	J	20cm	22.5cm
	K	20cm	21cm
	L	20cm	23cm

Bimetallic strips which consist of two different materials bonded together are then made from J, K and L. After heating for 5 minutes at 100°C, it was observed that the metallic strips bent. Based on the table above, which one of the following can be observed of the bimetallic strips after 5 minutes of heating?

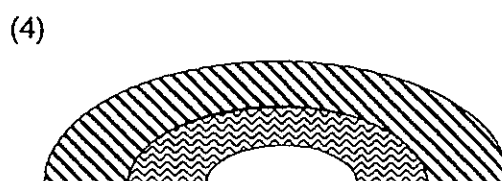
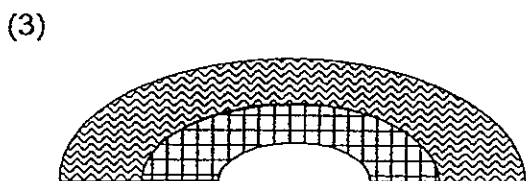
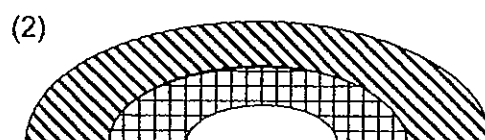
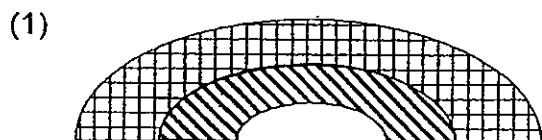

26. A heated metal ball was placed in a cup of cold water. Which one of the graphs below shows the temperatures of the ball and water over 30 minutes?

(1)

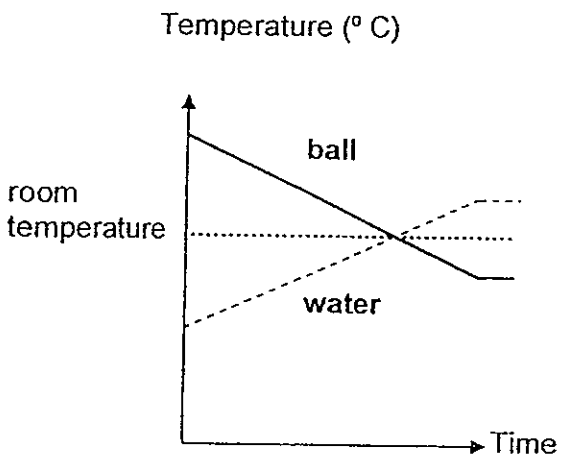

(2)

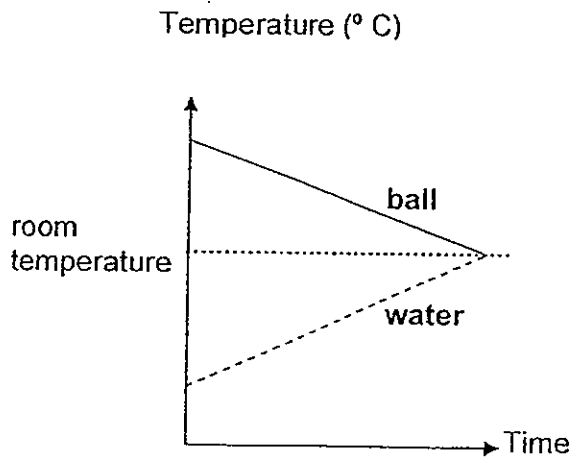

(3)

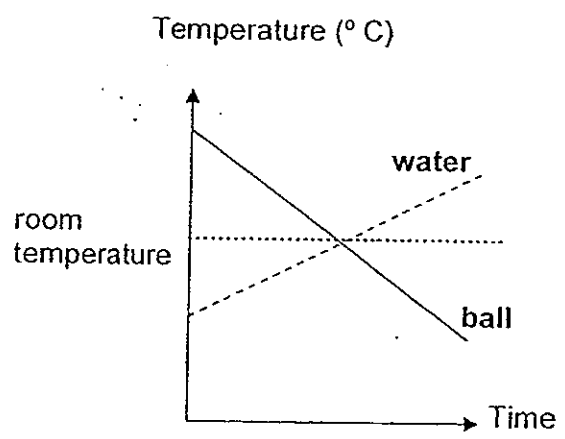

(4)

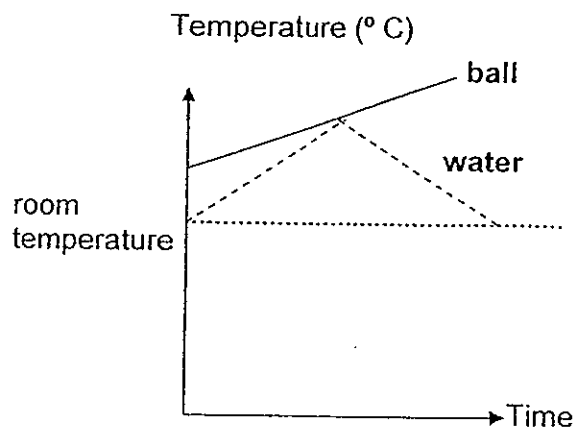

- 27 The graph below shows the changes in the temperature of water during an experiment. Part BD shows the temperature of the water as it was heated.

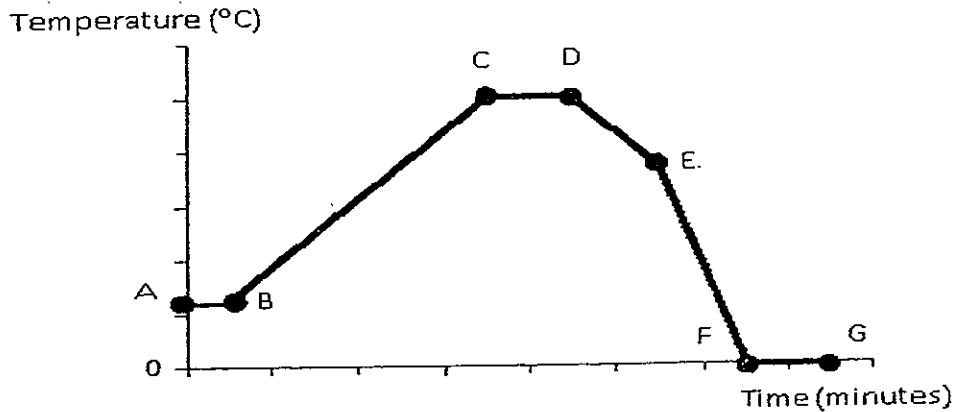

Based on the graph, which one of the following statements about the water is **not** correct?

- (1) Water is a solid at FG.
 - (2) Steam is formed at BC.
 - (3) Water is evaporating at AB.
 - (4) Water is gaining heat at CD.
- 28 The circuit below is set up with identical bulbs and four batteries. At first, bulb K was unlit while bulb J was lit with a brightness of 20 units. When the button is pushed downwards, the metal lever moves upwards to touch metal pin X (as indicated by the arrow).

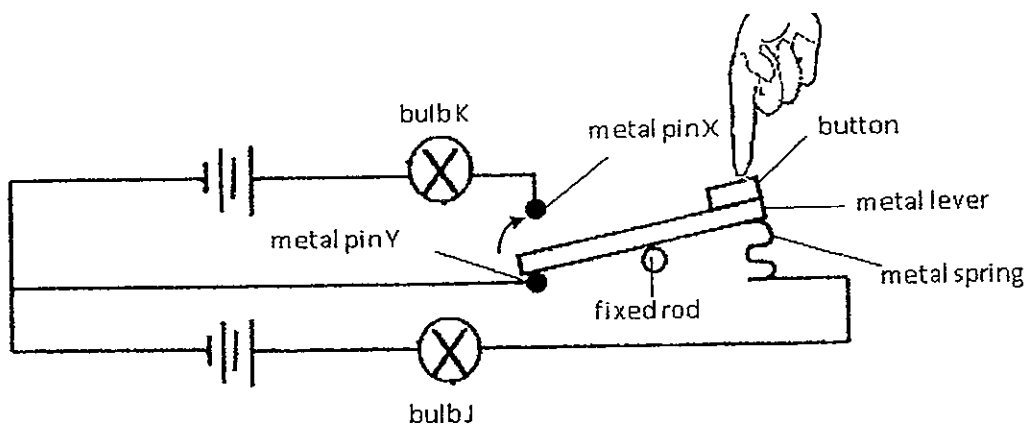

What would happen to bulbs J and K when the button is pushed down?

	bulb J	bulb K
(1)	unlit	unlit
(2)	as bright as 20 units	as bright as 20 units
(3)	brighter than 20 units	brighter than 20 units
(4)	unlit	as bright as 20 units

29. Tanya wanted to find out if the number of coils of wire would affect the strength of an electromagnet.

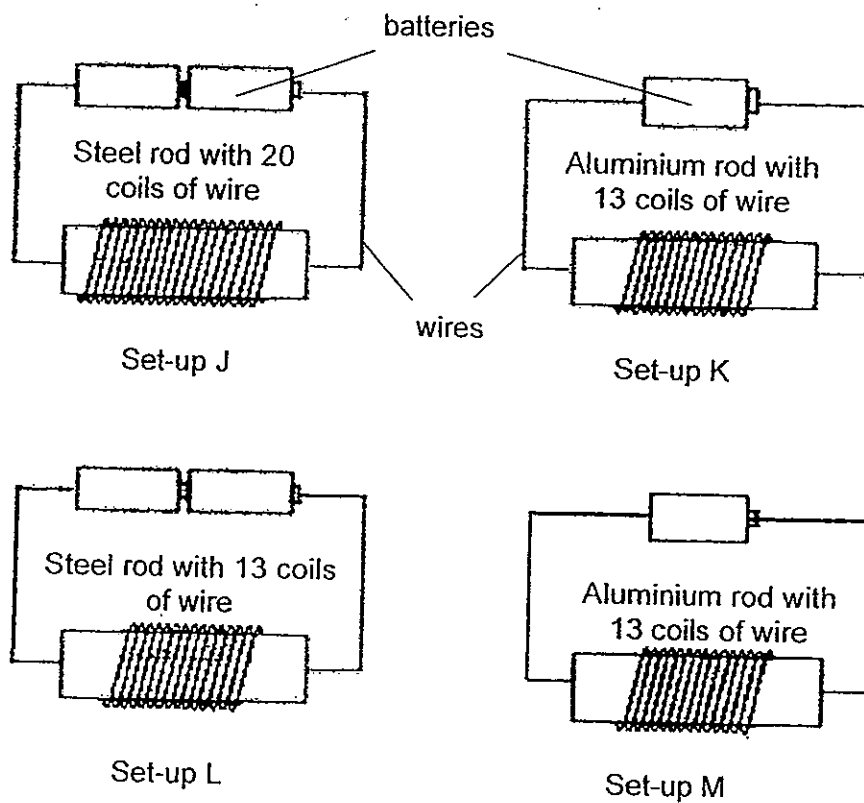

Which two set-ups should Tanya use so that it would be a fair test?

- (1) Set-ups J and K
- (2) Set-ups L and M
- (3) Set-ups J and L
- (4) Set-ups K and M

30. The diagram below shows an electric circuit with 3 bulbs, X, Y and Z and 3 switches, F, G and H.

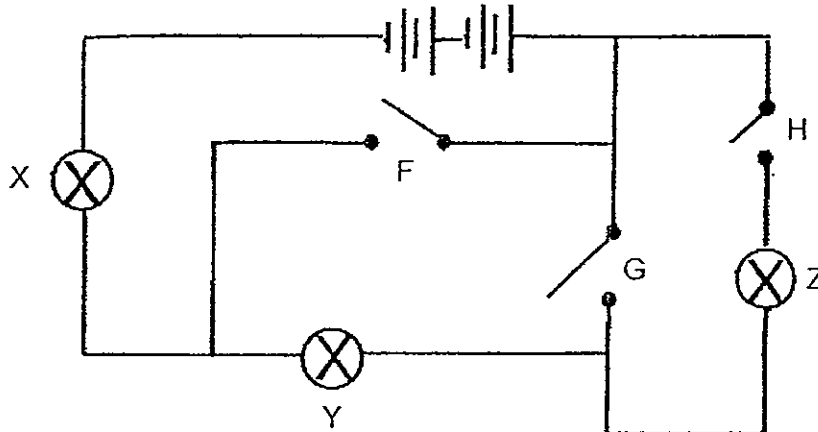

Which one of the following correctly shows the bulb(s) that would be lit when the switch(es) is/are closed?

	Switch(es) closed	Bulbs lit
(1)	F and G	X, Y and Z
(2)	G and H	Z
(3)	H	X, Y and Z
(4)	G	X and Z

End of Section A



Name : _____ ()

Class : Primary 5 _____

CHIJ ST NICHOLAS GIRLS' SCHOOL

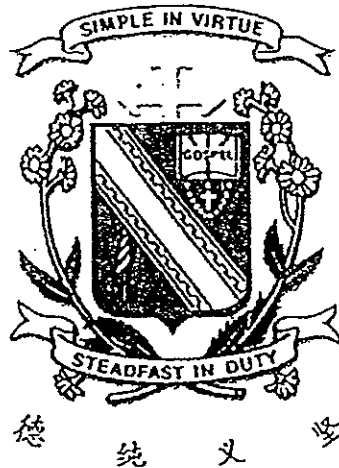

Primary 5
Continual Assessment 2 – 2012
SCIENCE
BOOKLET B

27 August 2012

Total Time for Booklets A and B: 1 hour 45 minutes

14 questions
40 marks

Do not open this booklet until you are told to do so.
Follow all instructions carefully.
Answer all questions.

This paper consists of 15 printed pages.

Booklet A	60
Booklet B	40
Total	100

For questions 31 to 44, write your answers in this booklet. The number of marks available is shown in the brackets[] at the end of each question or part question.

31. The diagram below shows a unicellular organism P. The organism was later cut into two parts along line X Y.

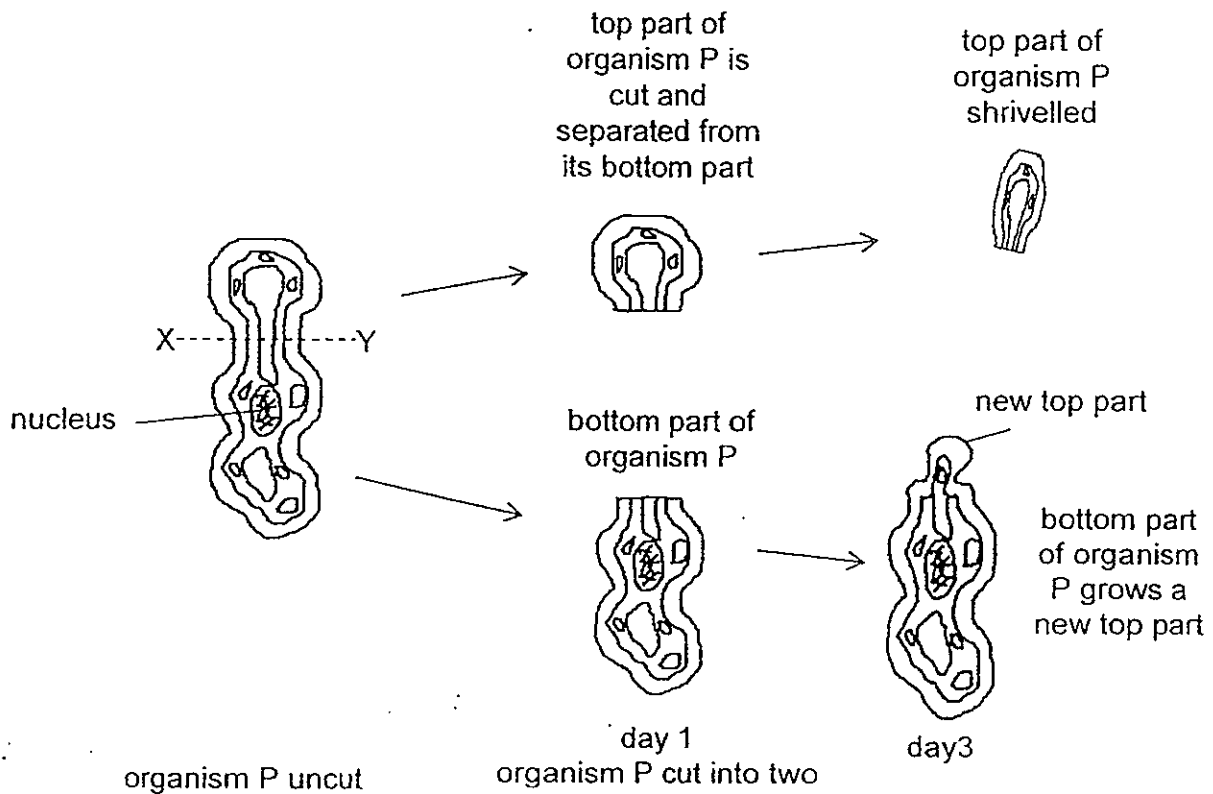

(a) Based on the above observation, what can you conclude about the function of the nucleus? [1]

(b) Organism P is able to make its own food when there is light. Name the substance in organism P that enables it to do this. [1]

32. The table below shows some information on some animal and plant cells, D, E, F and G. A tick (✓) indicates that the part of cell is present.

Parts of cell	Cell D	Cell E	Cell F	Cell G
Nucleus		✓	✓	✓
Chloroplast		✓		
Cell wall		✓	✓	

Group the cells in the classification table below. [2]

Animal cells	Plant cells

33. Mr Tan set up an experiment with some water plants. The water plants were weighed and then divided into two equal portions. The volume of gas collected in each test tube after 24 hours is shown below.

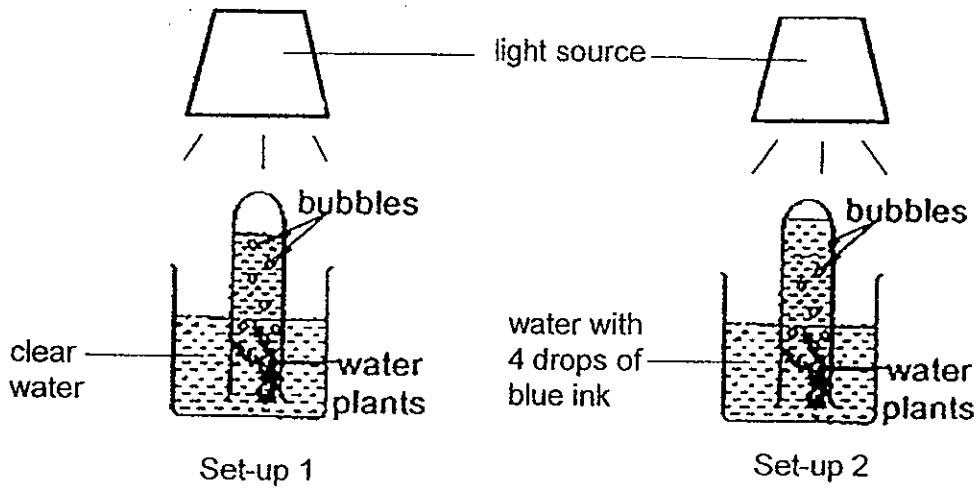

- (a) What is the aim of Mr Tan's experiment? [1]

- (b) The set-ups were left for a week and the plants were then weighed again. Predict the changes in the mass of the water plants in both set-ups 1 and 2 after 1 week. Explain your answer. [1]

- (c) Write a possible conclusion based on your answers in part (a) and (b). [1]

34. Samy set-up an experiment with two similar pots of plants, one with the leaves removed, as shown below. After 3 days, tiny water droplets were formed inside the plastic bag of set-up A but not in set-up B.

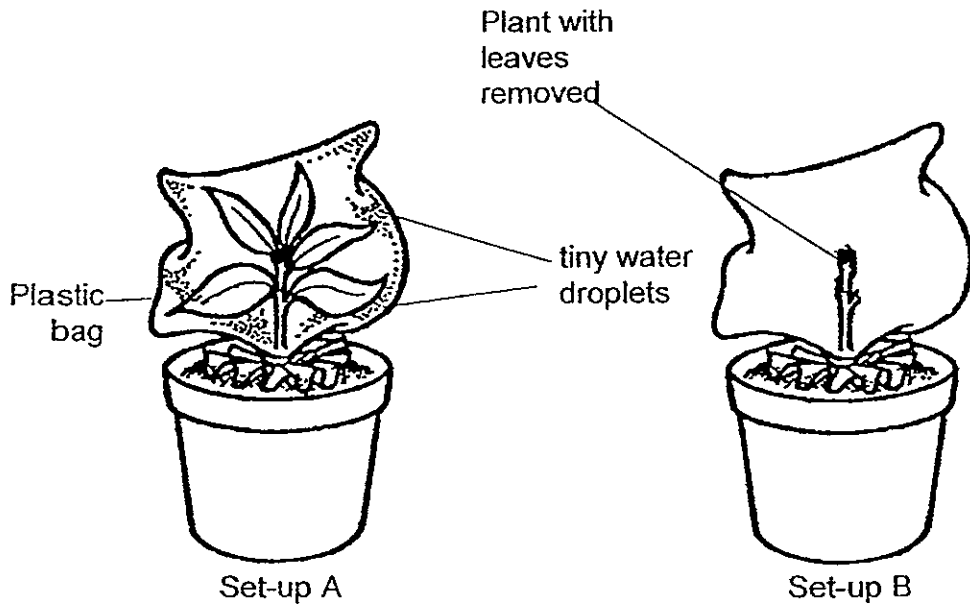

- (a) What is the variable change in the above experiment? [1]

- (b) If the aim of the experiment were to find out whether plants lose water through their leaves, name two other variables that have to be kept constant for the test to be fair. [1]

- (c) When potted plants are not watered for a period of time, they will curl up their leaves. Based on the observation above, how does the curling up of their leaves help the potted plants when there is insufficient water? [2]

35. The diagram below shows how the seeds of plant B and C are dispersed.



(a) From the diagram above, identify the method of dispersal of plant B and C and describe the characteristics of their seeds/fruit [2]

	Method of dispersal	Characteristics of the seeds/fruits
Fruit B		
Fruit C		

(b) Adult plants B and C were found growing on a plot of land as shown below. Write four of letters 'B' and 'C' each to indicate where the seeds of both plants will be dispersed given the direction of the wind. [2]

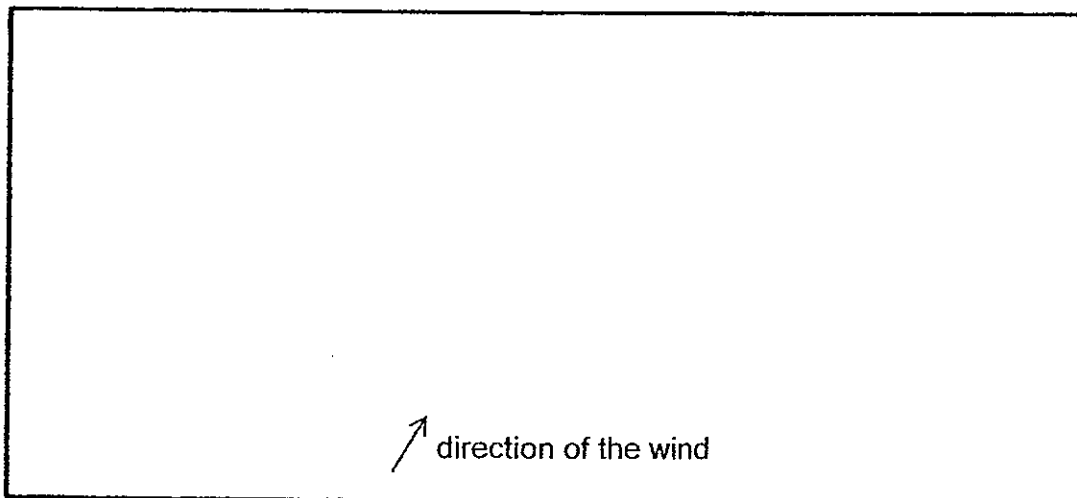

36. Observe the two flowers A and B as shown in the diagram below.

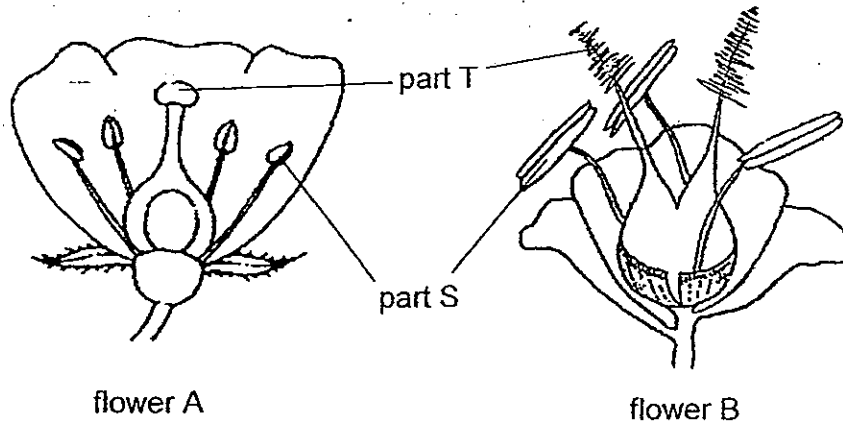

(a) Identify the parts S and T and state their functions. [2]

	Part S	Part T
Name of parts		
Function of parts		

(b) Based on the diagram above, identify the methods of pollination for flowers A and B. [1]

	Flower A	Flower B
Methods of pollination		

37. Angelina conducted an experiment to find out which material is the most absorbent. She hung four pieces of materials P, Q, R and S of the same size and thickness and soaked one of their ends in a basin of water. The water mark that appeared on each piece of materials P, Q, R and S at the end of the experiment is shown below.

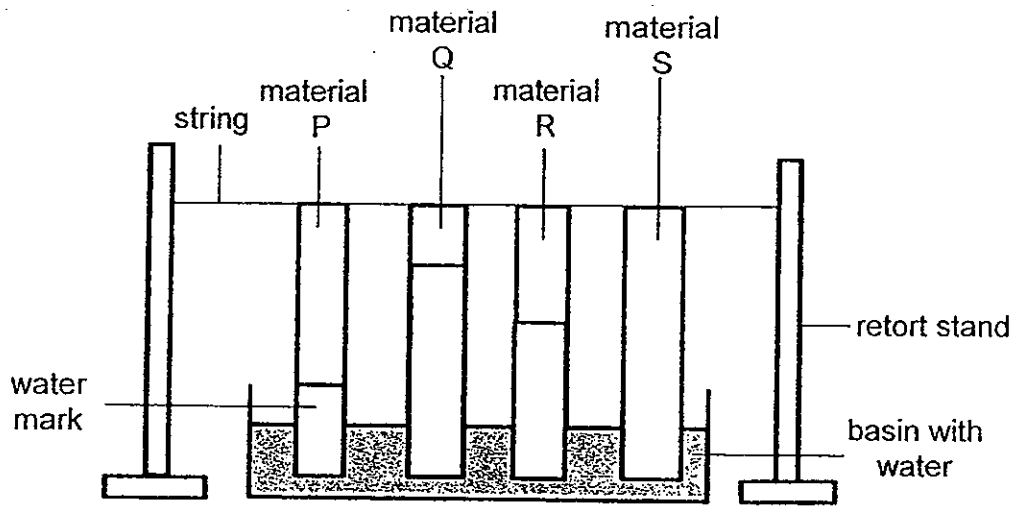

- (a) Based on the experiment above, what can she conclude about the four materials? [1]

- (b)

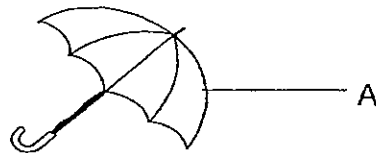

- Which material, P, Q, R or S, is most suitable for making part A of the umbrella as shown above? Explain your answer. [2]

38. Timothy conducted an experiment with two paper cups G and H of the same size and made of the same material. He poured an equal amount of hot water into each cup. Cup H has an uneven surface as shown below.

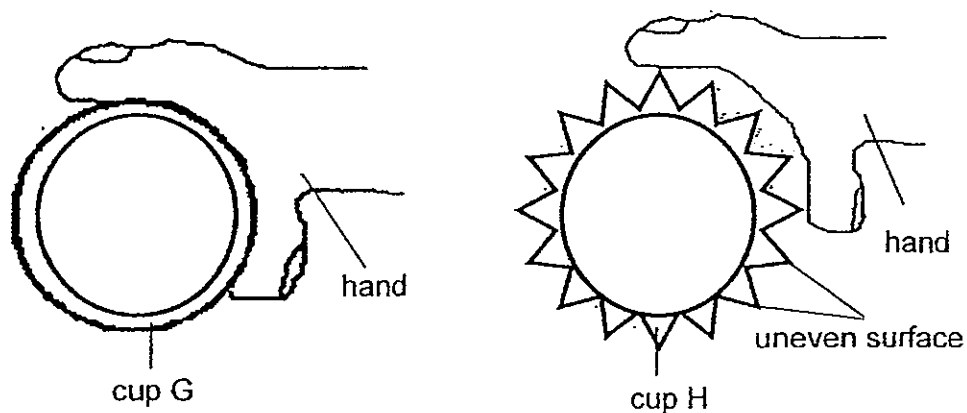

- (a) Which cup, G or H, will remain cooler to hold after one minute? Explain your answer. [1]

On a beach, a sea snail and a hermit crab were placed on the hot sand at the same time.

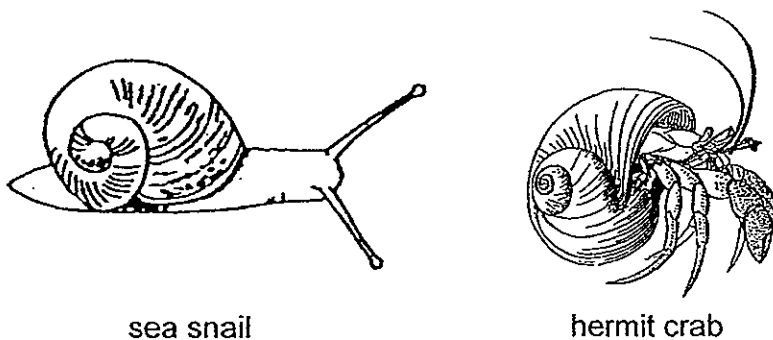

- (b) Based on your answer in part (a), which animal is more likely to experience an increase in its body temperature faster? Explain your answer? [2]

39. Two identical bottles A and B were used in an experiment as shown below. Bottle A contained air at room temperature while bottle B was filled with cold water measuring 5°C. The bottles were connected with a glass tube containing a drop of blue ink.

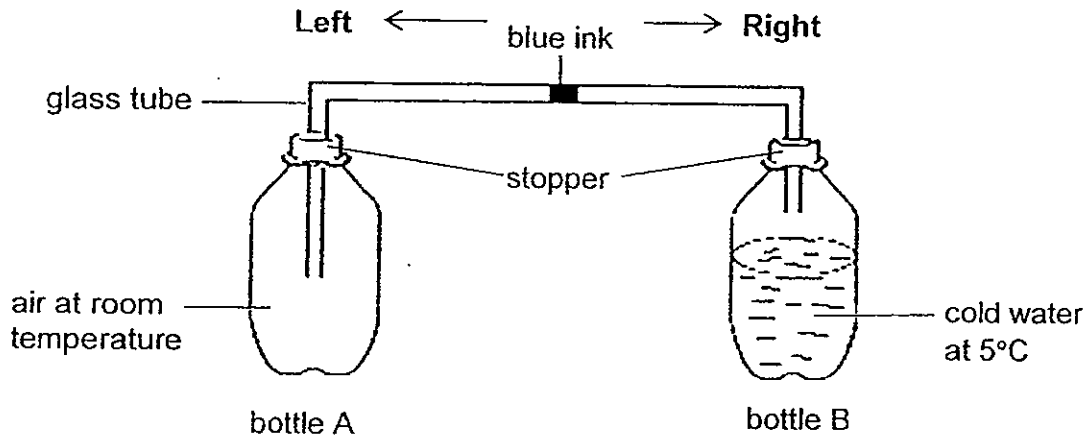

- (a) After 5 minutes, which direction, left or right, will the drop of blue ink move? [1]

- (b) Explain your answer in part (a). [1]

40. Look at the diagram of a saucepan below.

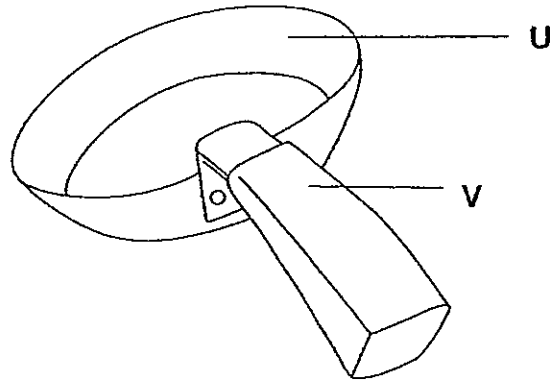

(a) Suggest a suitable material for making the following parts of the saucepan and give a reason for your choice. [2]

Parts of the saucepan	Suggest a suitable material	Reason
U		
V		

(b) Which material for U or V would be more suitable to make a box to contain ice so that it can be kept for a longer period of time without melting. Explain. [1]

41. Fandi was provided with two boxes, X and Y, containing the following electrical components.

Box X	Box Y
Two batteries One bulb Some wires	Four batteries Two bulbs Some wires

Fandi had to use all the electrical components in the boxes to construct two circuits so that all the bulbs in both circuits would have equal brightness.

Draw two possible circuit diagrams, one using components in Box X and the other using the components in Box Y, that would satisfy the conditions stated above.

(a) Circuit diagram using all the electrical components in Box X	[1]
(b) Circuit diagram using all the electrical components in Box Y	[1]

42. Keith set up an experiment as shown below.

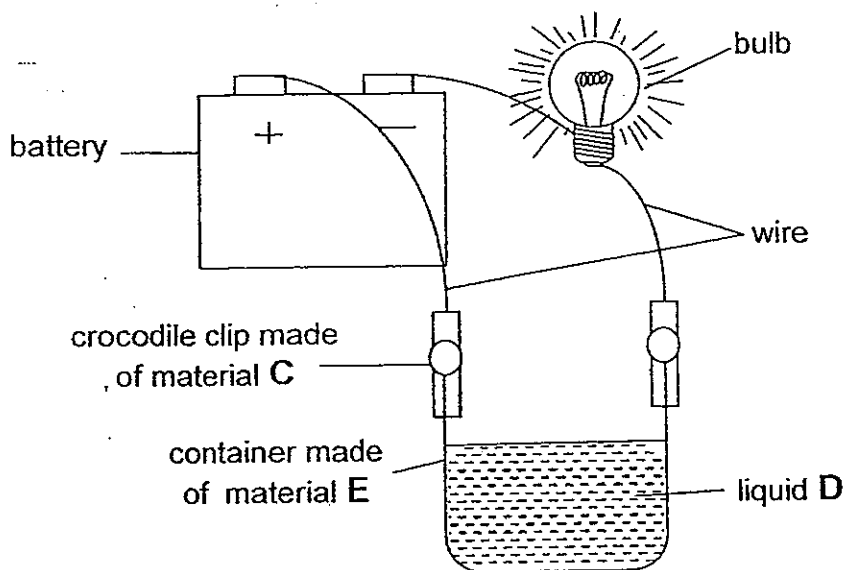

The bulb lit when the crocodile clips were connected to the container without touching the liquid.

Based on the above diagram and condition given, complete the table below.

[2]

	Must it be an electrical conductor?	Reason
Liquid D		
Material C		

43. Felicia conducted an experiment in an open field to find out if the Sun affects the rate of evaporation of water.

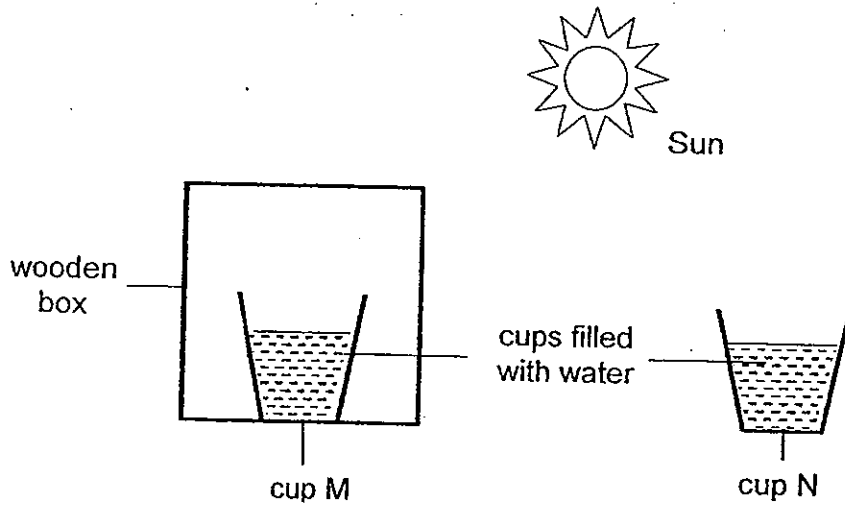

(a) Is the experiment a fair test? Explain your answer. [1]

(b) Which cup, M and N, would have a higher water level after one day? Explain your answer.

(c) State another factor that would affect the rate of evaporation which is not shown in the experiment above. [1]

44. In the set-up below, some salt solution was heated in a beaker until it boiled. A metal sheet was then placed over the beaker. After 15 minutes, Liquid X was formed at the bottom surface of the metal sheet and it was collected in a cup as shown below.

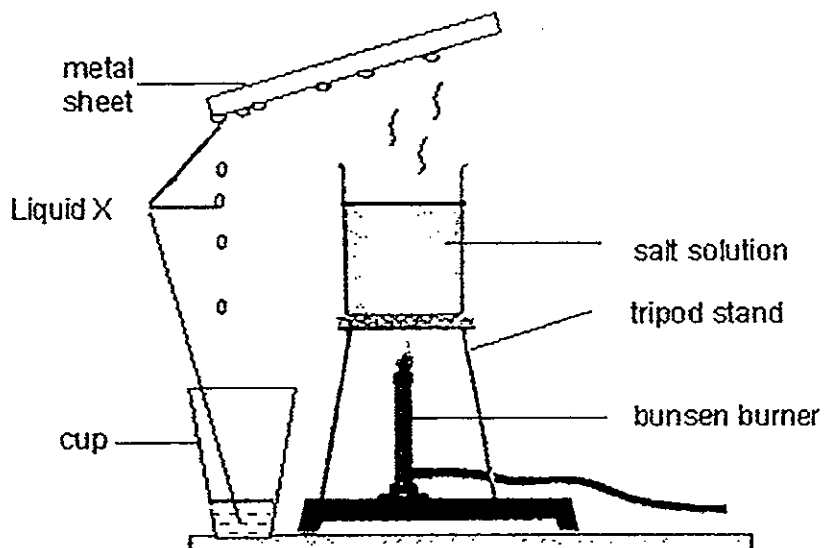

- (a) If the set-up were to represent the water cycle in nature, what could the salt solution and Liquid X on the metal sheet represent? [1]

Salt solution: _____

Liquid X: _____

- (b) Explain how Liquid X was formed. [2]

- (c) Explain why, after some time, there was less of Liquid X formed on the underside of the metal sheet.



ANSWER SHEET

EXAM PAPER 2012

SCHOOL : CHIJ
SUBJECT : PRIMARY 5 SCIENCE

TERM : CA2

Q1	Q2	Q3	Q4	Q5	Q6	Q7	Q8	Q9	Q10	Q11	Q12	Q13	Q14	Q15	Q16	Q17
1	2	4	3	2	2	3	2	4	4	2	4	1	3	1	4	3

Q18	Q19	Q20	Q21	Q22	Q23	Q24	Q25	Q26	Q27	Q28	Q29	Q30
1	3	1	2	2	3	4	1	2	2	1	3	3

31)a)Nucleus controls/ enables the growth of a new top part.
b)Chlorophyll.

32)Cell G Cell E
 Cell D Cell F

33)a)It is to find out if water with particles in it would affect the rate of photosynthesis.
b)Mass of water plant in set-up 1 increased or is higher but the plants in set-up 2 decreased. The plant in set-up 2 could not make as much food because the blue ink crease the transparency of the water.
c)The clearer the water, the higher the rate of photosynthesis.

34)a)The presence of leaves.
b)1)Amount of water given.
 2)Size of the plastic bag.
c)Curling up their leaves reduce exposed surface area and reduce water loss.

35)a) Fruit B : splitting / Hard/dry fruit wall/pod like that splits when ripe.
 Fruit C : Wind / It is small and light.

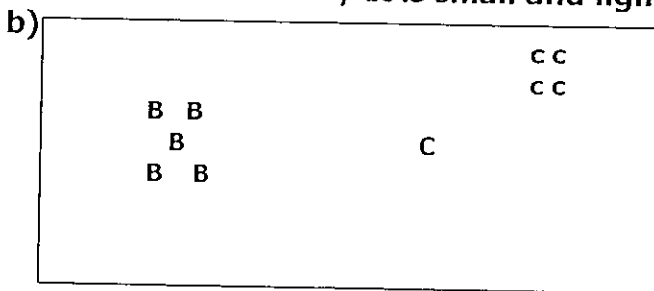

36)a)

	Part S	Part T
Name of parts	Anther	stigma
Function of Parts	Produces pollen grains to be carried by wind or insects for pollination.	Catches the pollen grains that form a tube down to the ovule to fuse with the egg cell.

b) Flower A : insects Flower B : wind

37)a) Material a is the most absorbent, followed by material R, P, and the Material S, which is waterproof.

b) Material S. It is waterproof so the person holding the umbrella would not get wet by the rain.

38)a) Cup H. It's uneven surface provides smaller contact surface with the hand hence less heat is conducted from the cup to the hand.

b) Snail does not have legs thus it has a larger body/ exposed surface in contact with the hot sand and allow the body to gain heat at a faster rate but the hermit crab has legs hence has a smaller body.

39)a) Right.

b) The cold water in Bottle B causes the air trapped in the bottle to contract and air lost heat to the cold water, thus pulling the blue ink to move to its right.

40)a) Metal / It is a good conductor of heat, so it will cook the food faster.

Plastic/ It is a poor conductor of heat, thus the person handling the saucepan would not get burned easily.

b) Material V. It is a poor conductor of heat, so the ice would not gained heat easily, Thus it can be kept for a longer period of time without melting.

41)a)

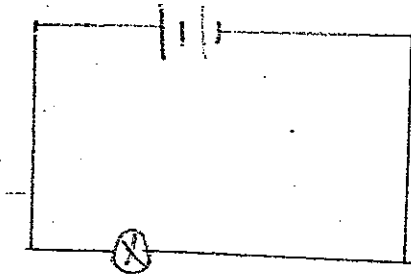

b)

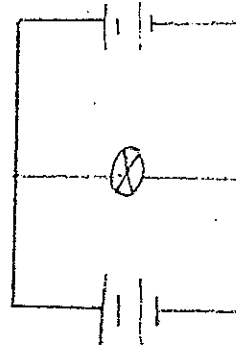

42)No / The crocodile clips are pegged onto the container and not immersed in Liquid D. Thus it does not need to conduct current.

Yes / The crocodile clips should be made of materials that are good conductor of electricity to allow the current to pass through.

43)a)No. Cup N is also exposed to the wind in the open field which will increase the rate of evaporation while Cup M is covered by the wooden box.

b)The water level in Cup M would be higher than Cup N as the wooden box helps to block off wind and some heat from the sun.

c)The area of exposed surface.

44)a)Salt solution : Water bodies.

Liquid X : Clouds/ mist

b)The salt solution gained heat and evaporated into hot water vapour. It then rises up and touches the cool surface of the metal sheet. It loses heat and condenses into water droplets. Since the metal sheet is slanted the water droplets rolled down and dripped into the cup.

c)The metal sheet gained heat from the hot water vapour. Thus the water vapour loses less heat to the metal sheet and condenses less.

