



## PRIMARY 5 END-OF-YEAR EXAMINATION 2012

Name : \_\_\_\_\_ ( ) Date: 30 October 2012

Class : Primary 5 ( ) Time: 8.00 a.m. - 9.45 a.m.

Parent's Signature : \_\_\_\_\_ Total Marks: \_\_\_\_\_ / 80

## SCIENCE BOOKLET A

### INSTRUCTIONS TO CANDIDATES

Write your name, class and register number.

Do not turn over this page until you are told to do so.

Follow all instructions carefully.

Answer all questions.

<b>Booklet</b>	
<b>A</b>	<b>40</b>



Section A (20 x 2 marks)

For each question, 1 to 20, four options are given. One of them is the correct answer. Make your choice (1, 2, 3 or 4). Shade the correct oval, (1, 2, 3 or 4) on the Optical Answer Sheet.

1. The graph below shows the number of days in each stage of the life cycle of an insect.

Number of Days in Each Stage of the Life Cycle of an Insect

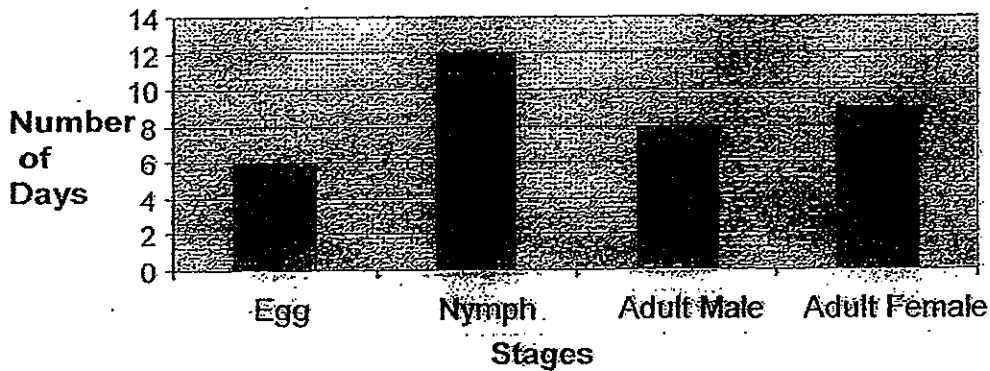

How many days would the insect take to become an adult after the egg is laid?

- (1) 12 days
- (2) 18 days
- (3) 26 days
- (4) 27 days

2. Study the classification chart below.

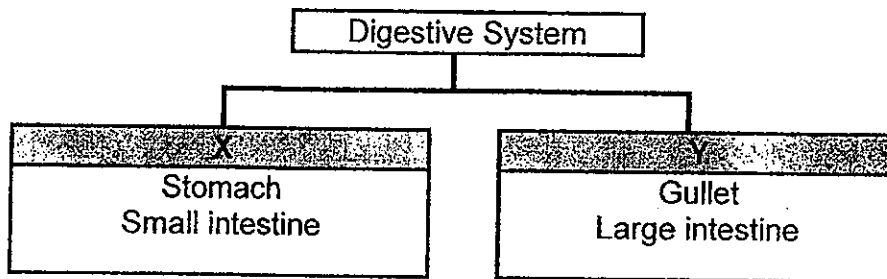

Which of the following are **suitable** headings for X and Y?

	X	Y
1)	Organs made up of muscles	Organs not made up of muscles
2)	Organs that produce digestive juices	Organs that do not produce digestive juices
3)	Organs that are not long	Organs that are long
4)	Organs that are not surrounded by blood vessels	Organs that are surrounded by blood vessels

3. Mrs Adam recorded the number of insects attracted to six types of flowers in the table below.

Flower	Smell	Colour of petals	Size of petals	No. of insects attracted
A	Sweet smell	Dull white	Small	10
B	No smell	Dull yellow	Big	10
C	Sweet smell	Bright red	Big	19
D	No smell	Bright blue	Medium	18
E	Sweet smell	Bright yellow	Small	16
F	No smell	Dull yellow	Medium	11

Which of the following is Mrs Adam's conclusion based on her observations?

- 1) Big-sized petals attract fewer insects than small-sized petals.
- 2) Medium-sized petals attract fewer insects than big-sized petals.
- 3) Brightly-coloured petals attract more insects than dull-coloured petals.
- 4) Sweet smelling flowers attract more insects than flowers with no smell.

4. Study the flow chart below.

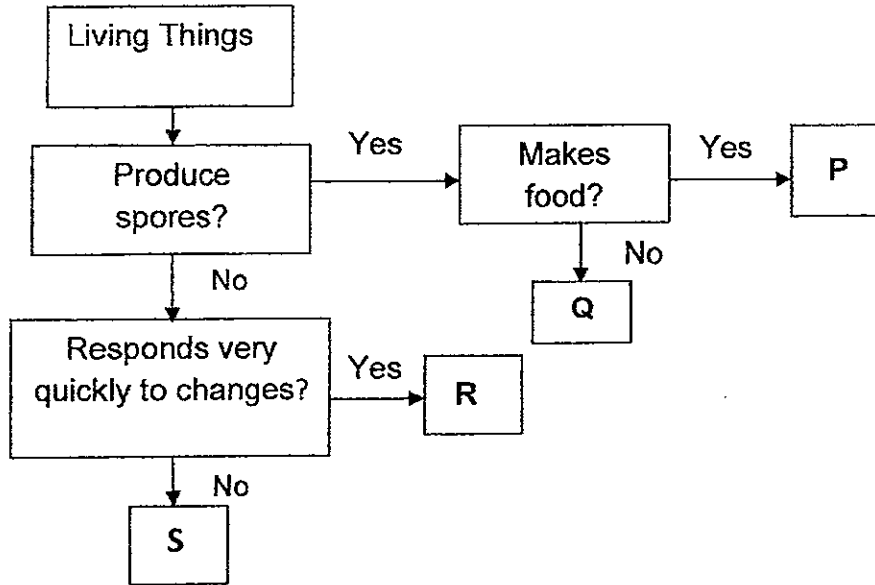

Which of the following represent P, Q, R and S?

	P	Q	R	S
(1)	Yeast	Rose Plant	Parrot	Rose Plant
(2)	Norway Pine	Bread Mould	Cactus	Guppy
(3)	Staghorn Fern	Bread Mould	Guppy	Cactus
(4)	Staghorn Fern	Norway Pine	Yeast	Parrot

5. An equal amount of water was poured into three containers, A, B and C, as shown below.

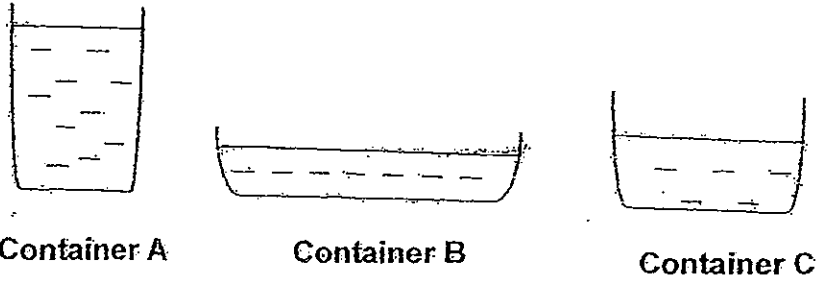

The containers were left in a classroom for 2 hours. Which of the following graphs shows the volume of water in the three containers over the 2 hours?

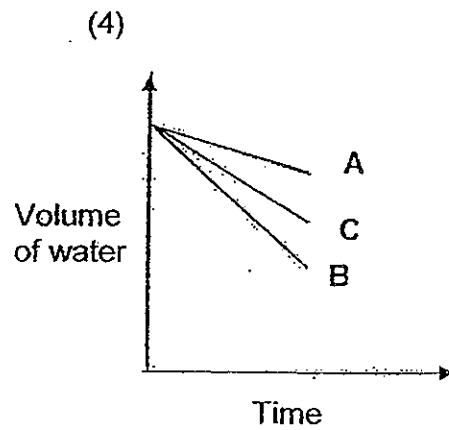
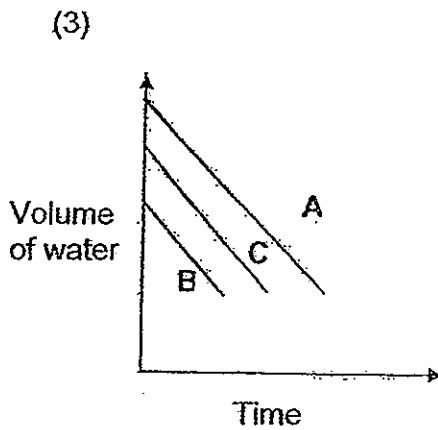
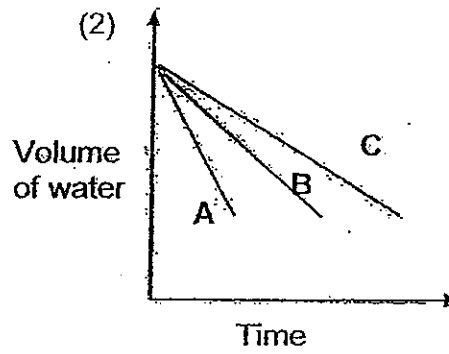
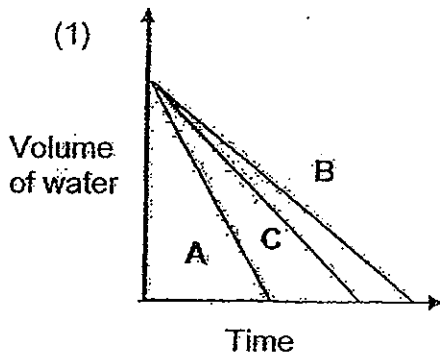

6. The set-up below is placed in a science laboratory at a temperature of 25 °C.

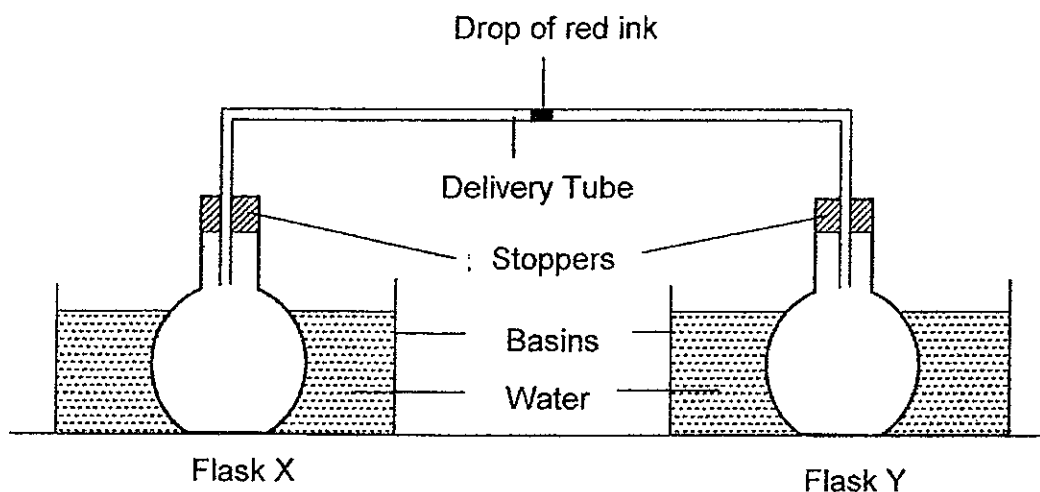

Which of the following will cause the fastest movement of the drop of red ink in the delivery tube towards Flask Y?

	Flask X	Flask Y
(1)	Placed in a basin of water at 85°C	Placed in a basin of water at 5°C
(2)	Placed in a basin of water at 15°C	Placed in a basin of water at 85°C
(3)	Placed in a basin of water at 5°C	Placed in a basin of water at 85°C
(4)	Placed in a basin of water at 15°C	Placed in a basin of water at 10°C

7. 6 similar plants, A, B, C, D, E and F, were placed in 3 different set-ups as shown below.

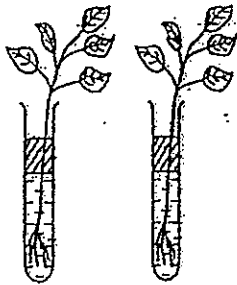

Leaves coated with oil  
Layer of oil on water  
**Set-up X**

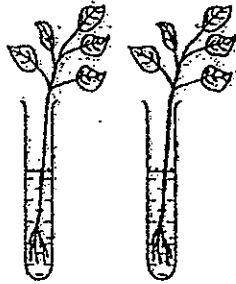

Leaves not coated with oil  
**Set-up Y**

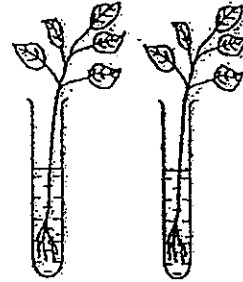

Leaves coated with oil  
**Set-up Z**

The volume of water in the test tubes was measured 2 days later. The results were as shown in the table below. Which of the plants were placed in Set-up Z?

	Volume of water in the test tubes (ml)					
	A	B	C	D	E	F
At the start	100	100	100	100	100	100
After 2 days	80	90	50	80	90	50

- (1) A and B
- (2) A and D
- (3) B and E
- (4) C and F



8. Gilbert set up an experiment in a dark room as shown in the diagram below.

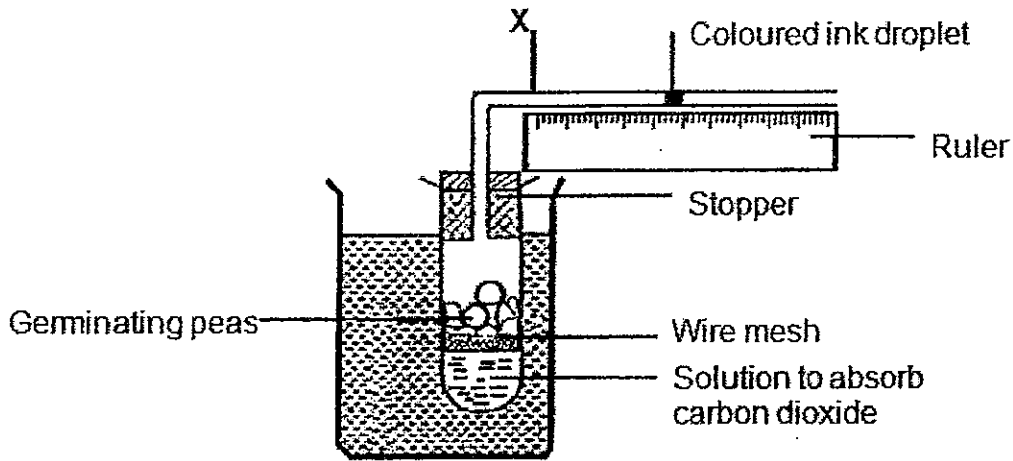

Gilbert recorded the different positions of the coloured ink droplet using the ruler. What would happen to the coloured ink droplet? Why?

- 1) It would move toward X because the germinating peas used up oxygen.
- 2) It would move away from X because the germinating peas gave out carbon dioxide.
- 3) It would remain in the same position because germination could not take place in a dark room.
- 4) It would remain in the same position because the germinating peas used up oxygen and gave out carbon dioxide.

9. Charlene has 3 basins of water, A, B and C, at different temperatures in front of her.

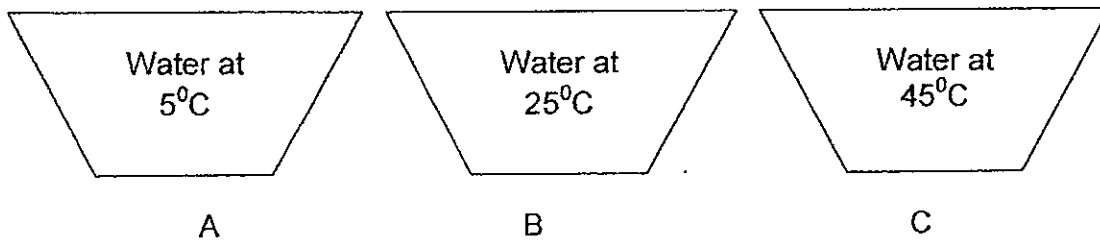

She places her left hand in A and her right hand in C for one minute. She then places both hands in B immediately. How do her hands feel?

	Left Hand	Right Hand
1)	Cool	Cool
2)	Warm	Warm
3)	Warm	Cool
4)	Cool	Warm

10. An athlete went for a 20 minute run. Which of the graphs below is likely to represent the changes in the athlete's pulse rate from the time he started running till after his run?

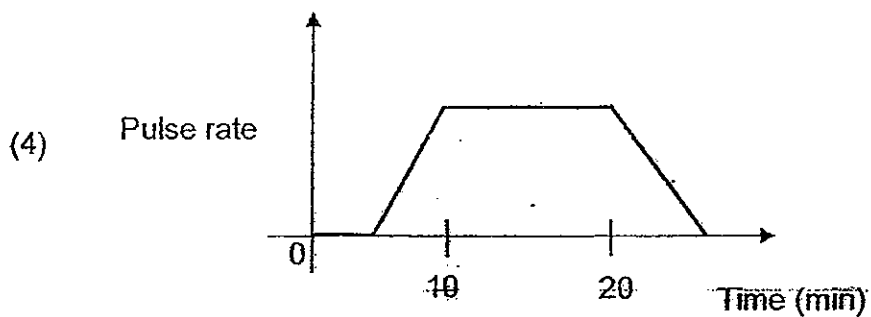
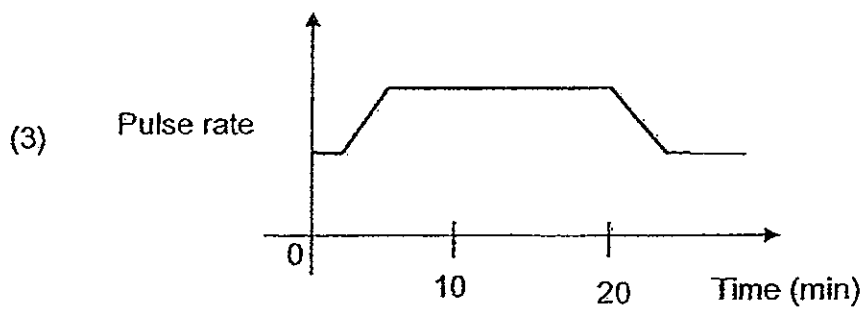
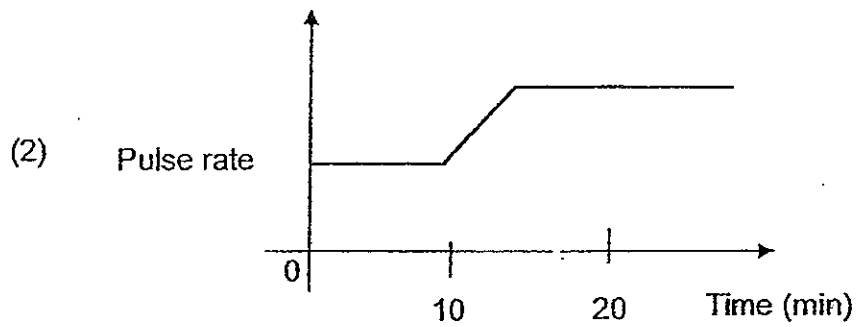
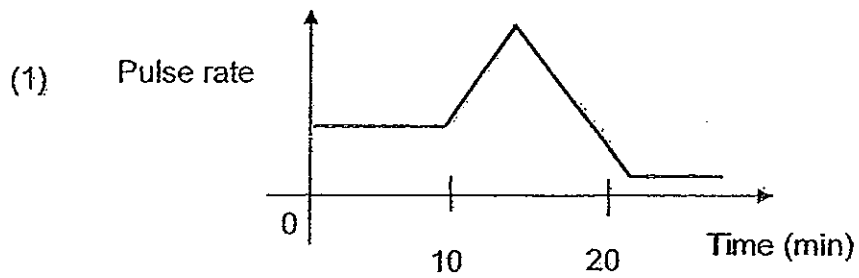

11. The diagram below shows how blood circulates in the human body.

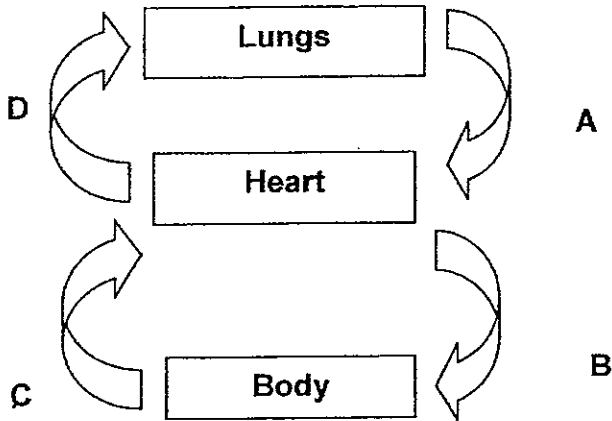

Which of the following bar graph shows the amount of oxygen in the different blood vessels?

1)

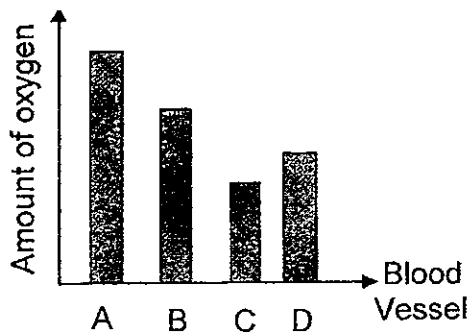

2)

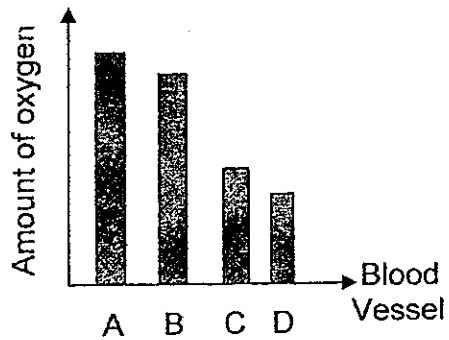

3)

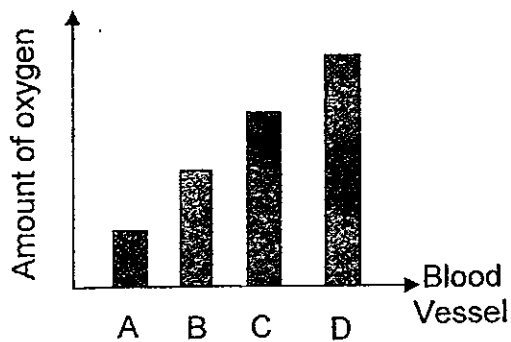

4)

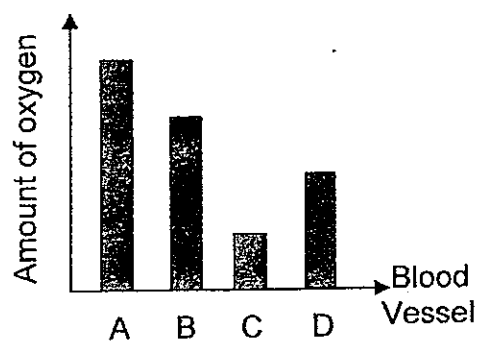

12. The following diagram shows a magnified part of a leaf.

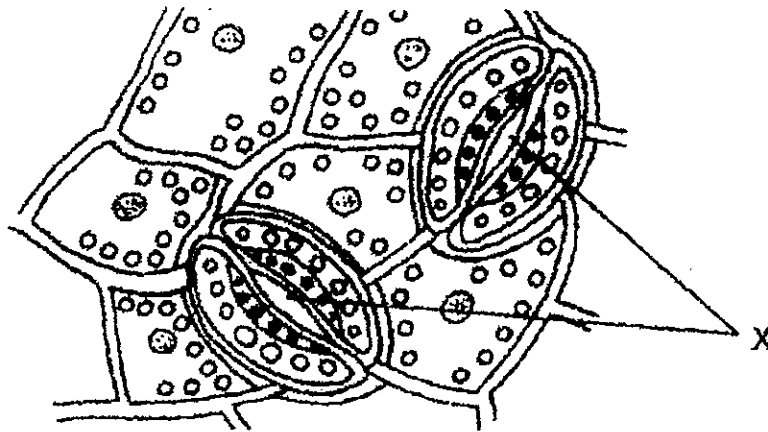

What is the function of the part labelled X?

- A: To allow light to enter the plant
- B: To allow excess water vapour to leave the plant
- C: To allow food to enter or leave the plant
- D: To allow oxygen and carbon dioxide to enter or leave the plant

- (1) A and B only
- (2) B and C only
- (3) C and D only
- (4) B and D only

13. Study the diagram below.

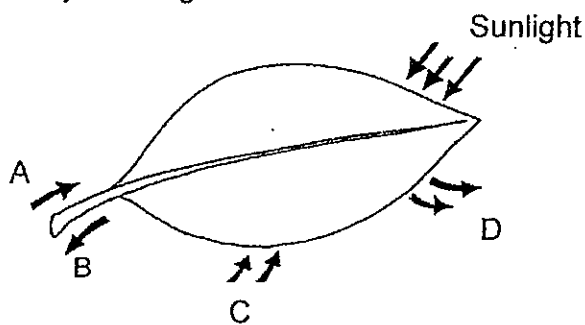

Which set of arrows represent the movement of water/ water vapour into and out of the leaf?

	Movement of water/ water vapour into the leaf	Movement of water/ water vapour out of the leaf
(1)	A	B
(2)	A	D
(3)	C	B
(4)	C	D

14. Shun Quan wanted to find out if the arrangement of bulbs in a circuit affects their brightness. He set up the circuits below using identical components.

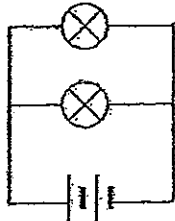

P

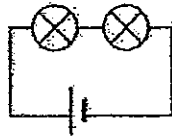

Q

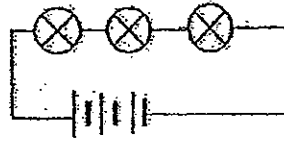

R

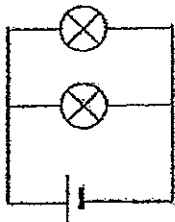

S

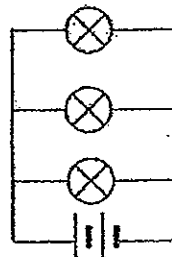

T

Which of these circuits should Shun Quan use to ensure a fair test?

- (1) P and S Only
- (2) P and T Only
- (3) Q and R only
- (4) Q and S Only

15. Eileen set up the electrical circuit below and switched on the switches S1, S2 and S3, at different times.

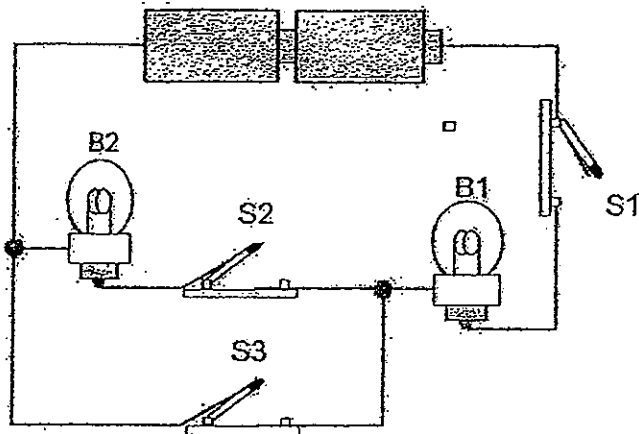

She recorded her observations of the bulbs, B1 and B2, in the table below. Which of the following is a correct observation?

	Switch			Bulb	
	S1	S2	S3	B1	B2
(1)	Switched off	Switched off	Switched on	Unlit	Lit up
(2)	Switched on	Switched on	Switched off	Lit up	Lit up
(3)	Switched off	Switched on	Switched off	Lit up	Unlit
(4)	Switched on	Switched off	Switched on	Unlit	Unlit

16. Robin set up four different electrical circuits within four boxes using identical components. He ensured that the distance between the heating coil and the base of the box is the same for all the boxes. Then he placed an evaporating dish containing 15 ml of water in each box as shown below.

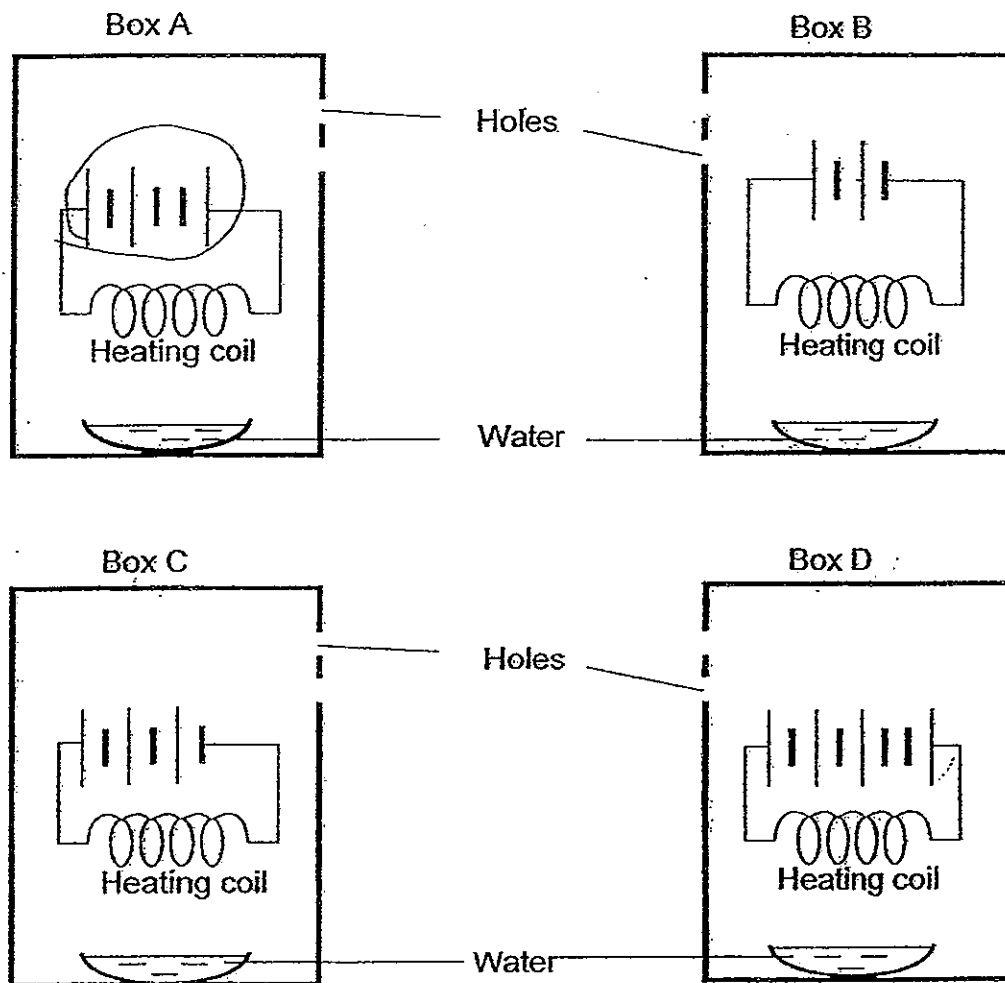

Which box allows the water to be completely evaporated first?

- (1) Box A
- (2) Box B
- (3) Box C
- (4) Box D

17. Dan set up an experiment as shown below.

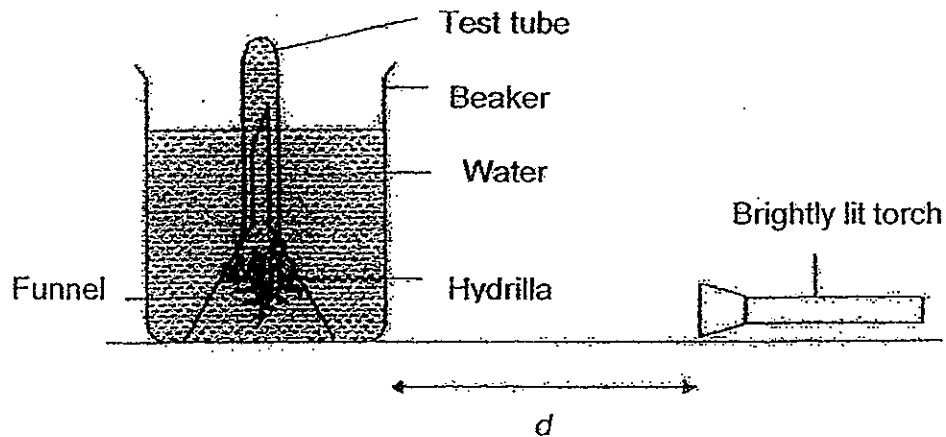

After 20 minutes, he counted the number of bubbles produced by the hydrilla over 30 seconds. He repeated the procedure five more times, by increasing the distance between the brightly lit torch and the beaker.

The graph below shows the relationship between the distance of the brightly lit torch from the beaker,  $d$  (cm), and the number of bubbles produced.

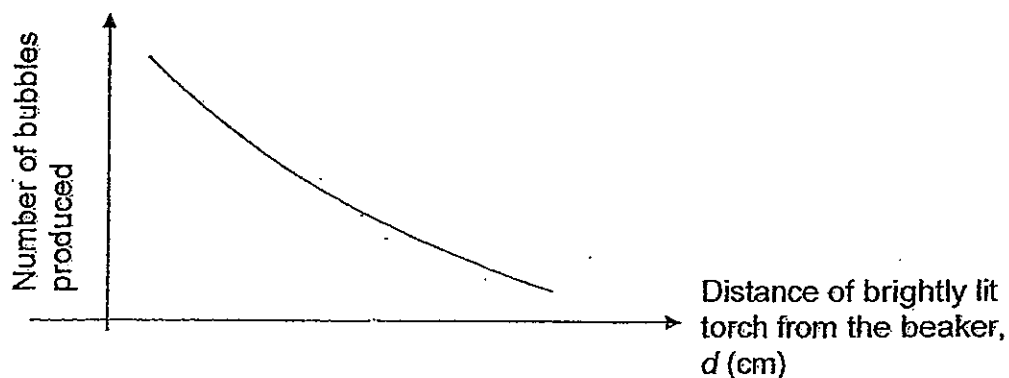

Which of the following can be inferred from the graph?

- (1) The greater the light intensity, the faster the rate of photosynthesis.
- (2) The greater the light intensity, the slower the rate of photosynthesis.
- (3) The greater the distance of the light source from the beaker, the more oxygen produced.
- (4) The greater the distance of the light source from the beaker, the more carbon dioxide taken in.



18. Natalia connected a bulb and some batteries to three metal rods, made of the same material but of different lengths, as shown in the diagram below. She closed Switch 1 (S1) but kept the other two switches open. Then she observed the brightness of the bulb. She repeated the experiment by closing Switch 2 (S2) and Switch 3 (S3) in turn. At any one time, only one switch was closed.

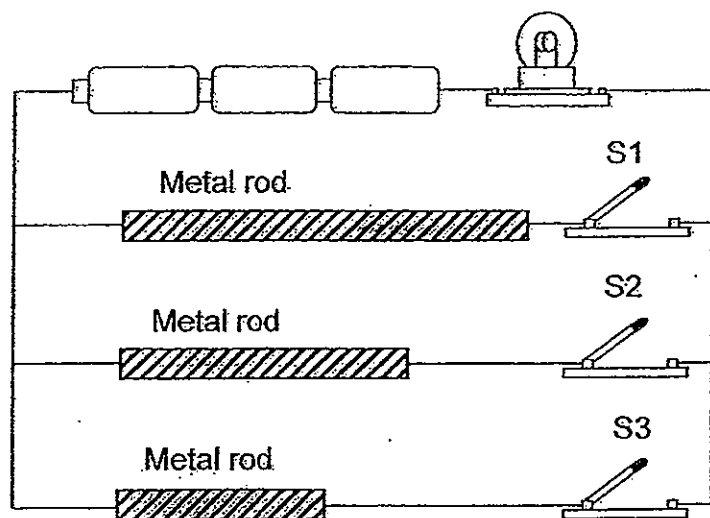

What was the aim of Natalia's experiment? ..

- (1) To find out if the number of batteries affect the brightness of the bulb.
- (2) To find out if the length of the metal rods affects the brightness of the bulb.
- (3) To find out if the arrangement of the switches affects the brightness of the bulb.
- (4) To find out if the arrangement of the metal rods affects the brightness of the bulb.

19. A grandfather's clock has a pendulum that swings to and fro as shown below.

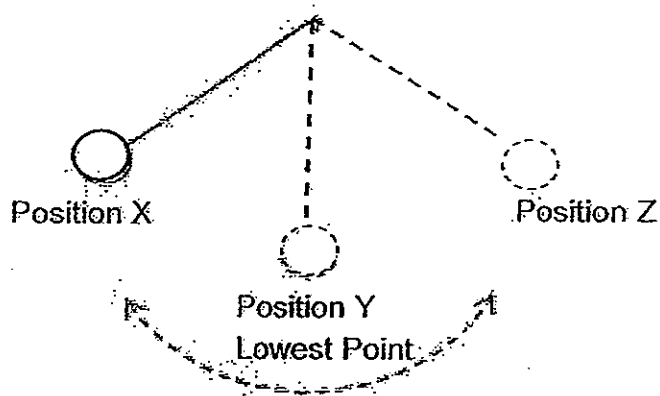

As the pendulum swings, its kinetic energy is calculated and plotted in the graph below.

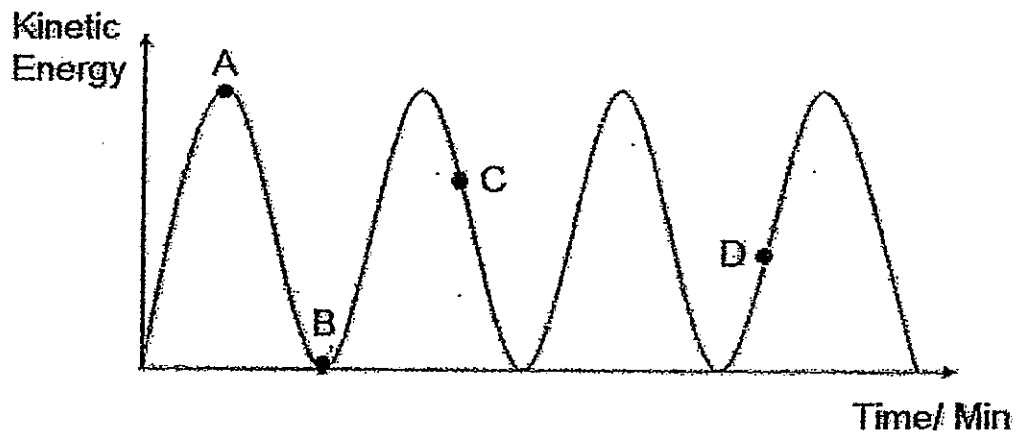

Which point, A, B, C or D, on the graph represents the kinetic energy of the pendulum when it is at position Y?

- (1) Point A
- (2) Point B
- (3) Point C
- (4) Point D

20. Ching Wen set up the experiment below.

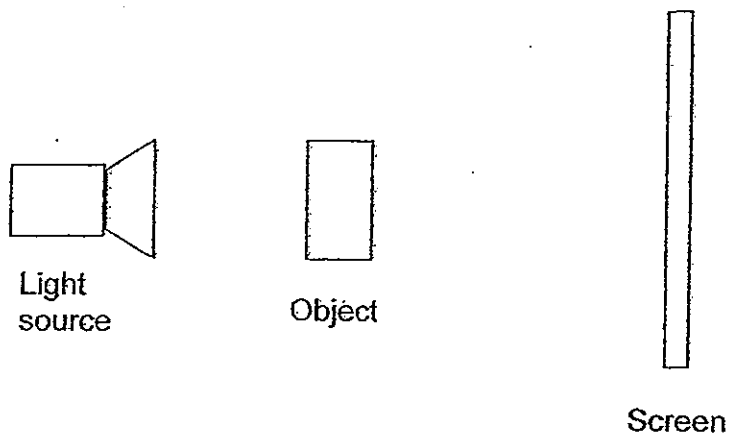

She placed the object of length 10cm at different distances from the light screen and observed the shadow cast on it. She recorded her results in the table below.

Distance between the screen and the object	Length of the shadow
5cm	?
10cm	20cm
15cm	25cm
20cm	30cm
25cm	35cm

What is the length of the shadow when the distance between the screen and the object is 5 cm?

- (1) 5cm
- (2) 10cm
- (3) 15cm
- (4) 20cm

End of Booklet A



**PRIMARY 5 END-OF-YEAR EXAMINATION 2012**

Name : \_\_\_\_\_ ( ) Date: 30 October 2012

Class : Primary 5 ( )

Time: 8.00 a.m. - 9.45 a.m.

Parent's Signature : \_\_\_\_\_

**SCIENCE  
BOOKLET B**

**INSTRUCTIONS TO CANDIDATES**

Write your name, class and register number.

Do not turn over this page until you are told to do so.

Follow all instructions carefully.

Answer all questions.

<b>Booklet</b>	
<b>B</b>	<b>40</b>

**Section B (40 marks)**

For each question, 21 to 34, write your answers in the spaces provided.

21. When James poured water into the glass funnel in Set-up A, only a few drops of water entered the beaker. However, when James poured water into the glass funnel in Set-up B, the water flowed more freely into the beaker.

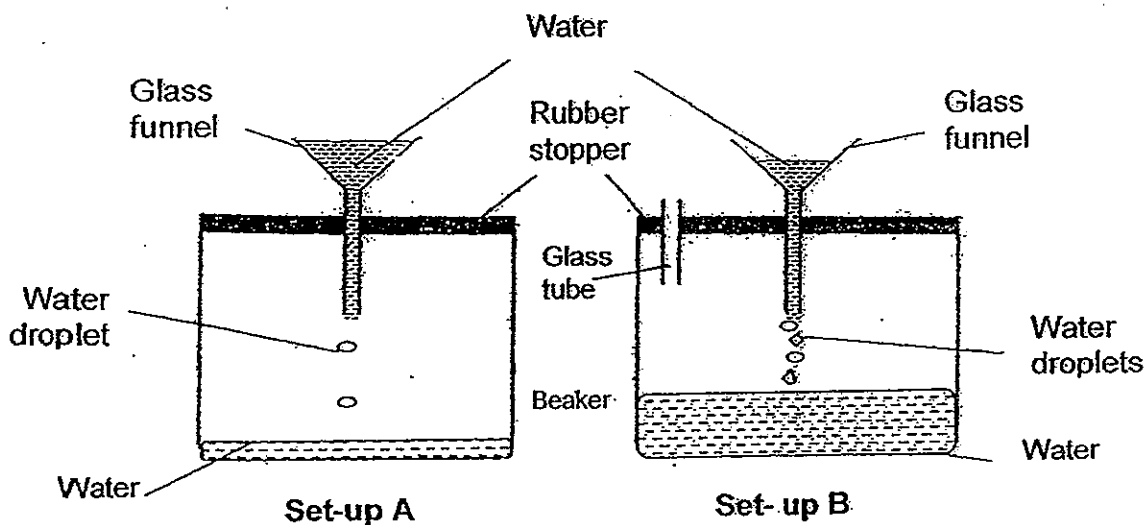

- (a) Explain why only a few drops of water entered the beaker in Set-up A. [2]

---

---

---

- (b) What is the purpose of the glass tube in Set-up B?

---

---

22. Serene placed three pieces of material, A, B and C, on a dry table cloth. Then 15 ml of water was poured slowly onto each material.

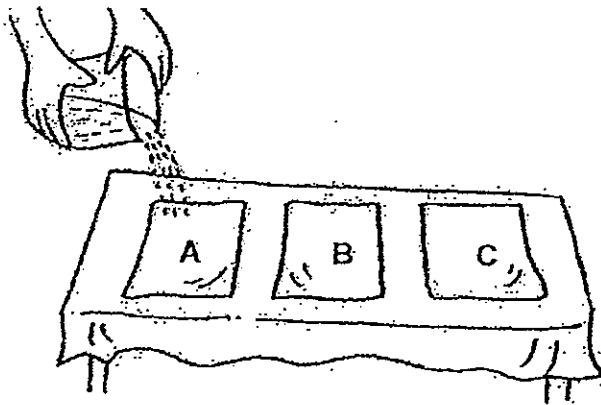

Serene recorded her observations in the table below.

Material	Observation
A	Water seeps into A. The table cloth under A remains dry.
B	Water does not seep through or into B. The table cloth under B remains dry.
C	Water seeps through C. The table cloth under C becomes wet.

- (a) Read the following carefully and fill in each box with A, B or C. [1]

i) Material  is most suitable to make bath towels.

ii) Material  is most suitable to make raincoats.

- (b) Fill in the boxes below with the materials A, B and C, in order of their absorbency of water. [1]

Least absorbent  $\longrightarrow$  Most absorbent

23. At a restaurant, Paul observed a conveyor belt moving from the kitchen to the tables where the people were seated. This reminded him of how a plant transports food.

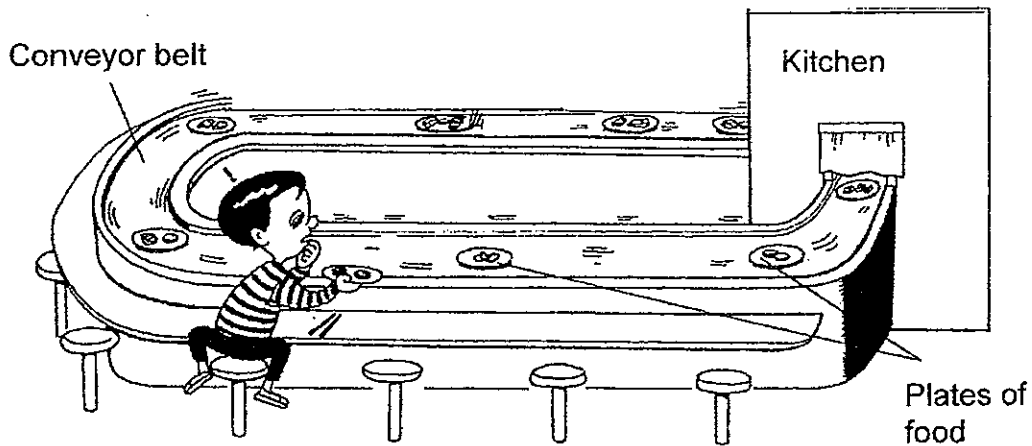

(a) Identify the plant parts that match the parts of the restaurant as given below. [1]

Restaurant	Plant Part
i) Kitchen	
ii) Conveyor Belt	

(b) Explain your choice of plant part in (a)(i). [1]

---



---

24. Study the three set-ups below.

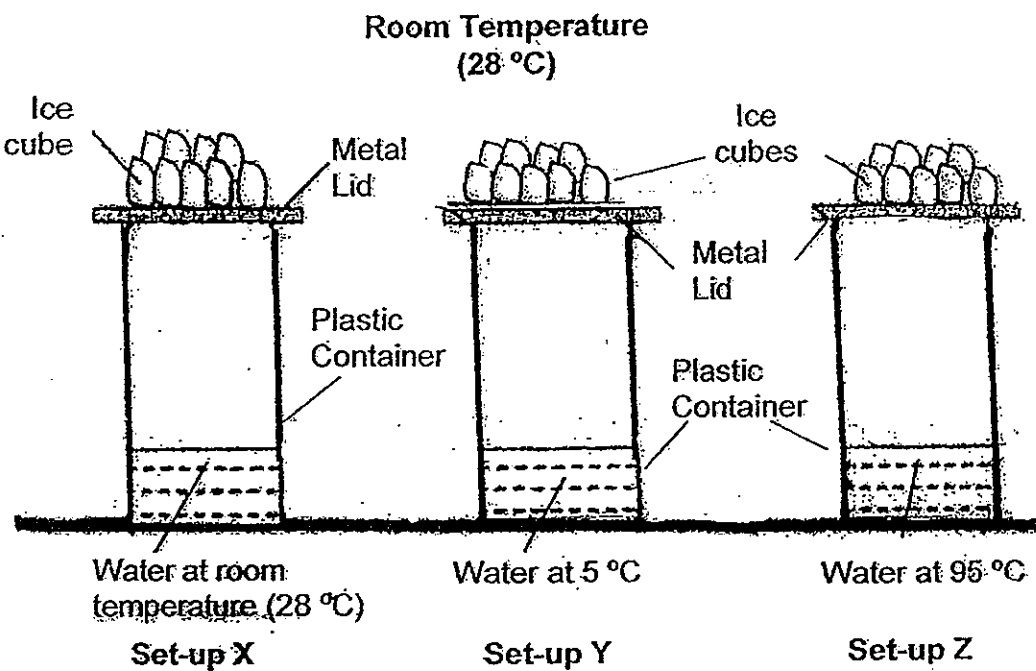

- (a) Draw the water droplets that formed in Set-up X, Set-up Y and Set-up Z above. [1]
- b) Which of the set-ups, Set-up X or Set-up Z, has a faster rate of condensation? Explain your answer. [2]

---

---

---



25. Jeremy exercised for 40 minutes. He recorded his pulse rate and breathing rate in the table below.

Time during the exercise	Pulse rate (beat / min)	Breathing rate (breath / min)
5 minutes	72	30
10 minutes	90	60
15 minutes	110	75
20 minutes	133	86

- (a) What is the relationship between the time during the exercise, and the pulse rate and breathing rate? [1]

---

---

- (b) Explain why the heart must beat faster with time as he exercises. [1]

---

---

56 A plant has pale green leaves and is placed in a beaker of water. A teacher removes the outer ring of the stem of the plant. Both the side view and cross-sectional view of the stem are shown in Figure A and Figure B respectively.

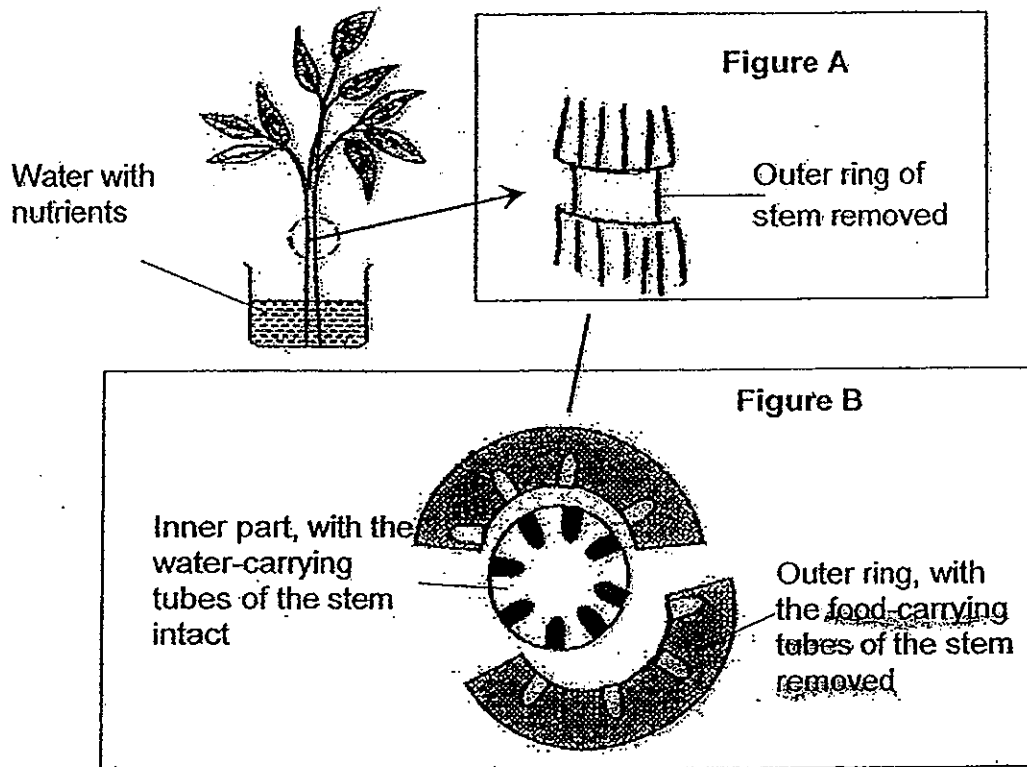

Observations of the stem after 3 days are illustrated in Drawing 1 and Drawing 2.

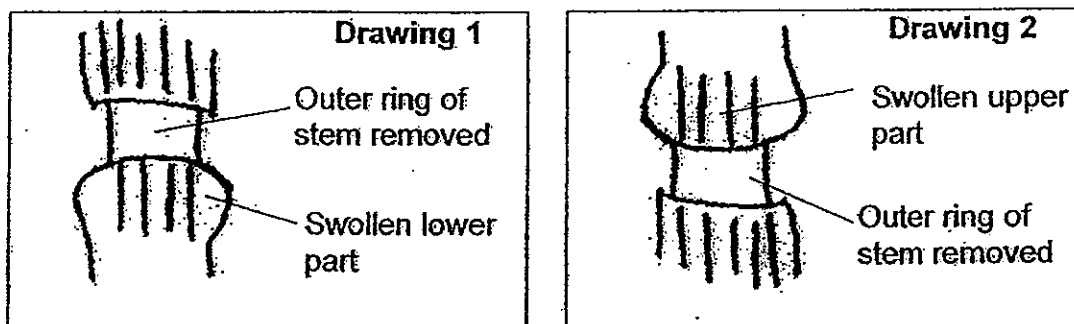

Which drawing, Drawing 1 or Drawing 2, shows the correct observation after 3 days? Explain your answer. [2]

---



---



---

27. Kenneth observed two different cells from a same plant as shown below.

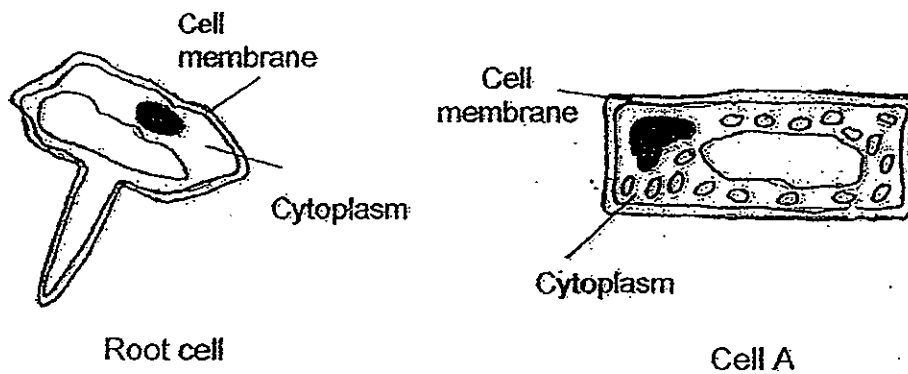

(a) Name the cell part that gives the cell its regular shape. [1]

---

---

(b) Identify 2 parts of a plant where you are most likely to find Cell A. [1]

---

---

(c) Identify the cell part which is present in Cell A but not in the root cell. Suggest a reason why the root cell does not have this cell part. [2]

---

---

---

28. The flow chart below shows the functions of various organs in the human body.

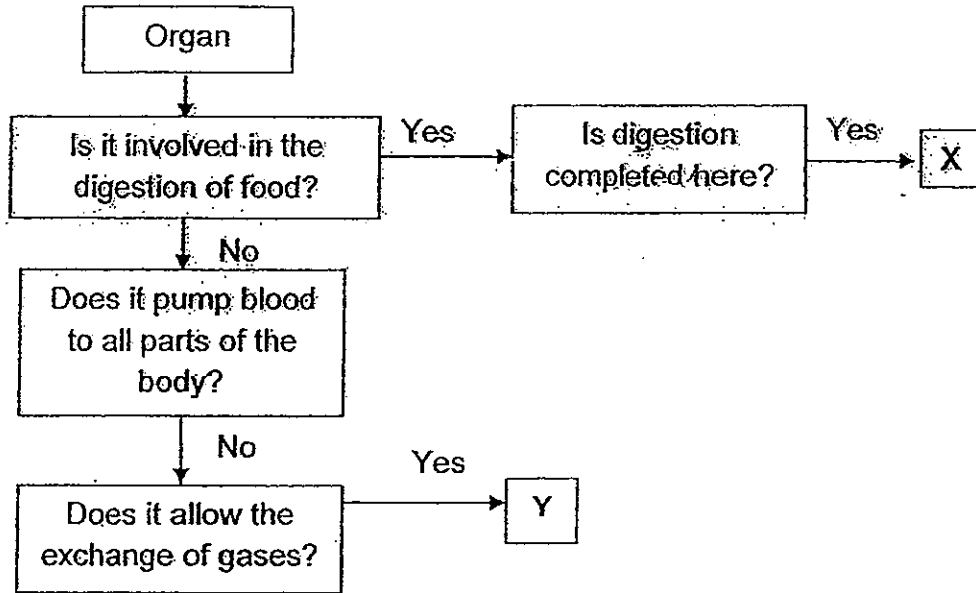

(a) Which organs do the letters X and Y represent? [1]

X: \_\_\_\_\_ Y: \_\_\_\_\_

The diagram below shows how blood travels in the body. Arrows A, B, C, D, represent the movement of blood.

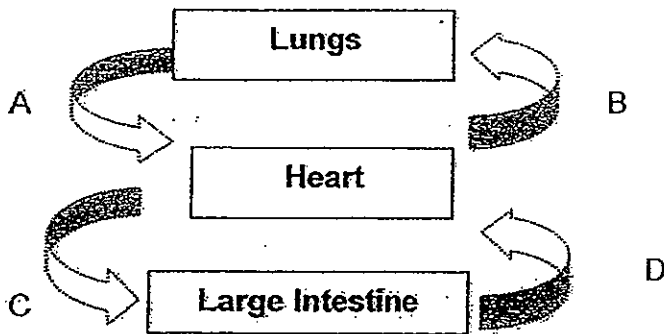

(b) Which <sup>arrow</sup> carries the highest amount of water? Explain why. [2]

---



---



---

29. Liza had a plant plot in her farm. She recorded observations of the plants grown in the table below.

Time (days)	Number of Type A flowers observed	Number of fruits that grow from Type A flowers	Number of Type B flowers observed	Number of fruits that grow from Type B flowers
10	20	0	35	0
20	50	0	55	0
30	80	0	75	30
40	90	0	95	50
50	110	0	115	68
60	115	0	130	88

(a) Based on Liza's observation, which type of flower, A or B, is **female** and which is **male**? Explain why. [2]

---



---

(b) Liza always noticed a greater number of young plants growing at her farm, which had bee hives around, compared to another farm which had none. How are the bees helpful to the plants? [1]

---



---

30. The diagram below shows a tunnel and the circuit on a toy train. The bulb only lights up when the whole train has entered the tunnel fully.

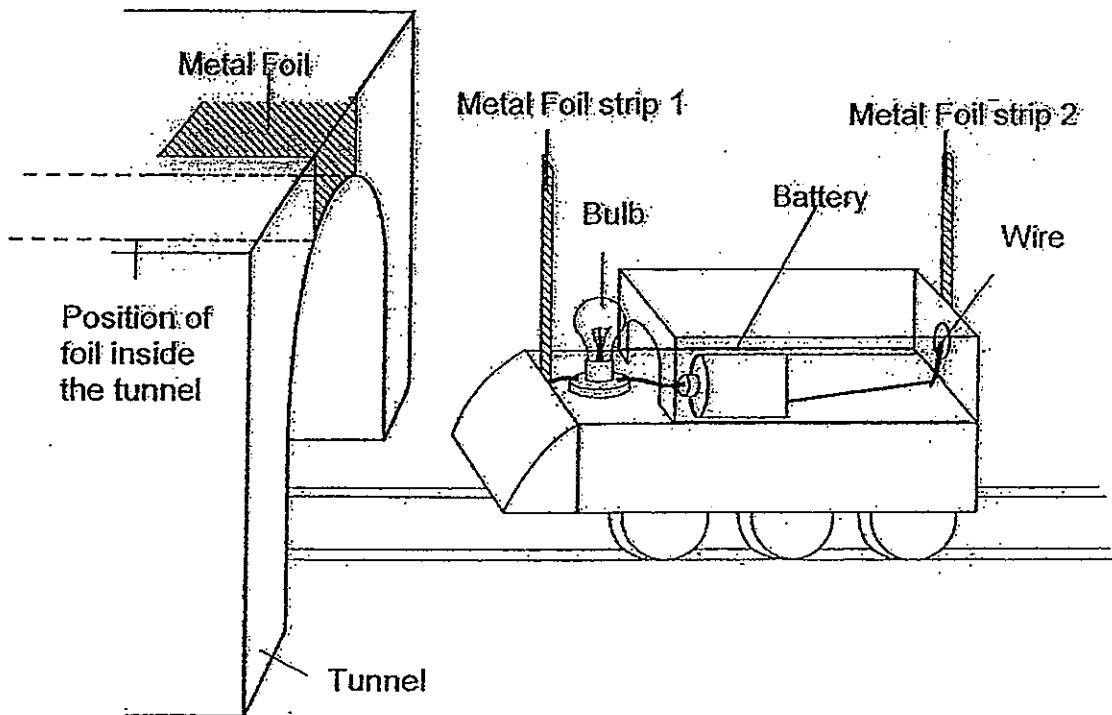

- (a) Explain why the bulb only lights up when the whole train completely enters the tunnel. [2]

---

---

---

- (b) The toy train in (a) closely resembles the electric bus tram in the early days of Singapore as shown below.



Tram

When one of the connecting wires snaps due to prolonged usage, the tram stops moving. Explain why this is so. [1]

---

---

31. Angelina wanted to find out if the arrangement of the bulbs would affect the brightness of the bulbs. Using the same electrical components, she set up 2 circuits, Circuit A and Circuit B, as shown below.

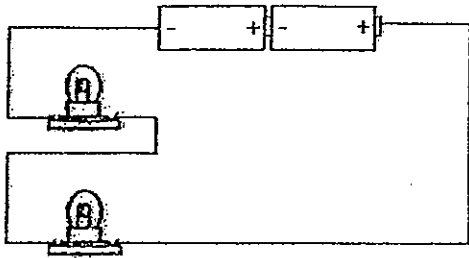

Circuit A

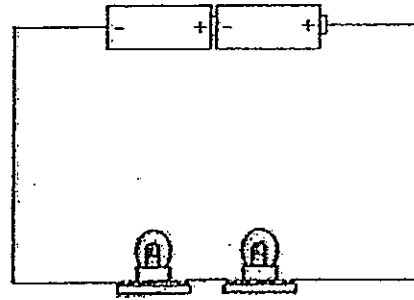

Circuit B

Angelina concluded that the arrangement of the bulbs does not affect the brightness of the bulbs.

- (a) Angelina's teacher told her that she had made the wrong conclusion. Explain why. [1]

---

---

- (b) **DRAW** in the space below, a **circuit diagram** using circuit symbols, to show the correct arrangement of the bulbs in order to have a fair test. [2]



32. Four rods of the same length but different materials are attached to a tank filled with hot water as shown below.

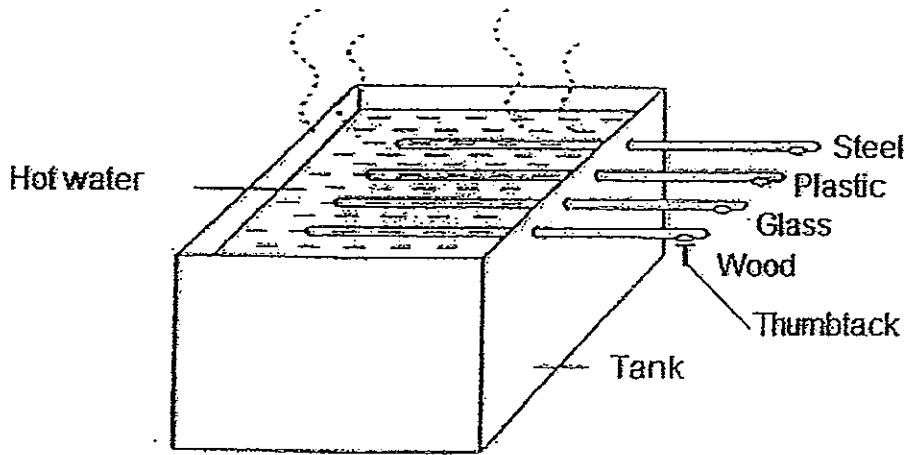

Four thumbtacks are held on the ends of the four rods with wax. As the rods get heated up, the thumbtacks on the ends of the rods begin to fall off one by one.

- (a) Arrange the materials according to the time at which the thumbtack will drop off. [1]

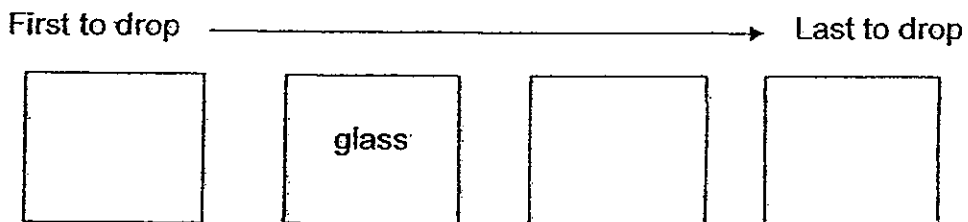

- (b) For the thumbtack that drops first in (a), explain why the material that the rod is made of causes that to happen. [1]

---



---

- (c) Styrofoam cups are used in McDonald's to serve hot coffee. Explain why. [2]

---



---

33. Members of the Science Club hung different weights on identical parachutes like the one as shown below. They released the parachutes from the third storey of their school. They then repeated their experiment and recorded the time taken for the parachute to land on the ground in the table below.

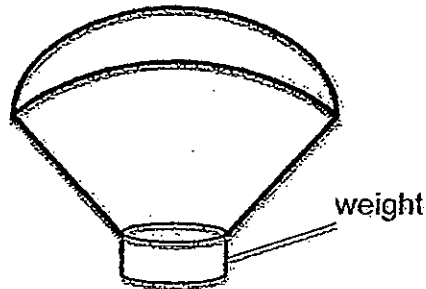

	Time taken (seconds)			
	1st try	2nd try	3rd try	Average Time
Parachute with 30g weight	122	120	121	121
Parachute with 40g weight	102	104	103	103
Parachute with 50g weight	80	84	82	82
Parachute with 60g weight	62	60	61	61
Parachute with 70g weight	41	40	40	40

- (a) What is the aim of the experiment? [1]

---



---

- (b) The members noticed that the parachute with the 70g weight made a louder sound when it hit the ground compared to the parachute in the 40g weight. Explain why this is so. [1]

---



---

- (c) What did the members do to make their results reliable? [1]

---



---

34. A school team carried out an investigation to see how high a basketball can bounce when it was dropped from different heights as shown below.

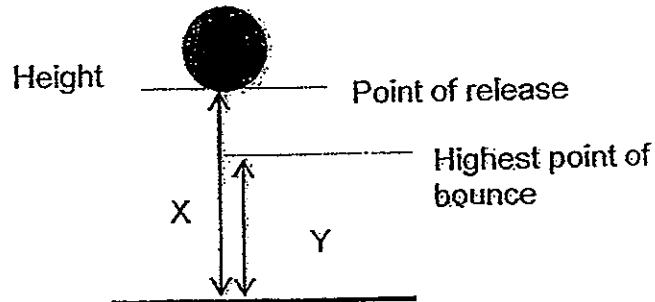

X (cm)	30	60	90	120	150
Y (cm)	19	45	65	83	120

- (a) From the information in the table, what is the relationship between the bouncing height and the dropping height of the basketball? [1]

---



---

- (b) Explain why the highest point of bounce is always lower than the point of release. [1]

---



---

- (c) Predict the highest height of bounce of the basketball if it is dropped from a height of 105cm. [1]

---



---

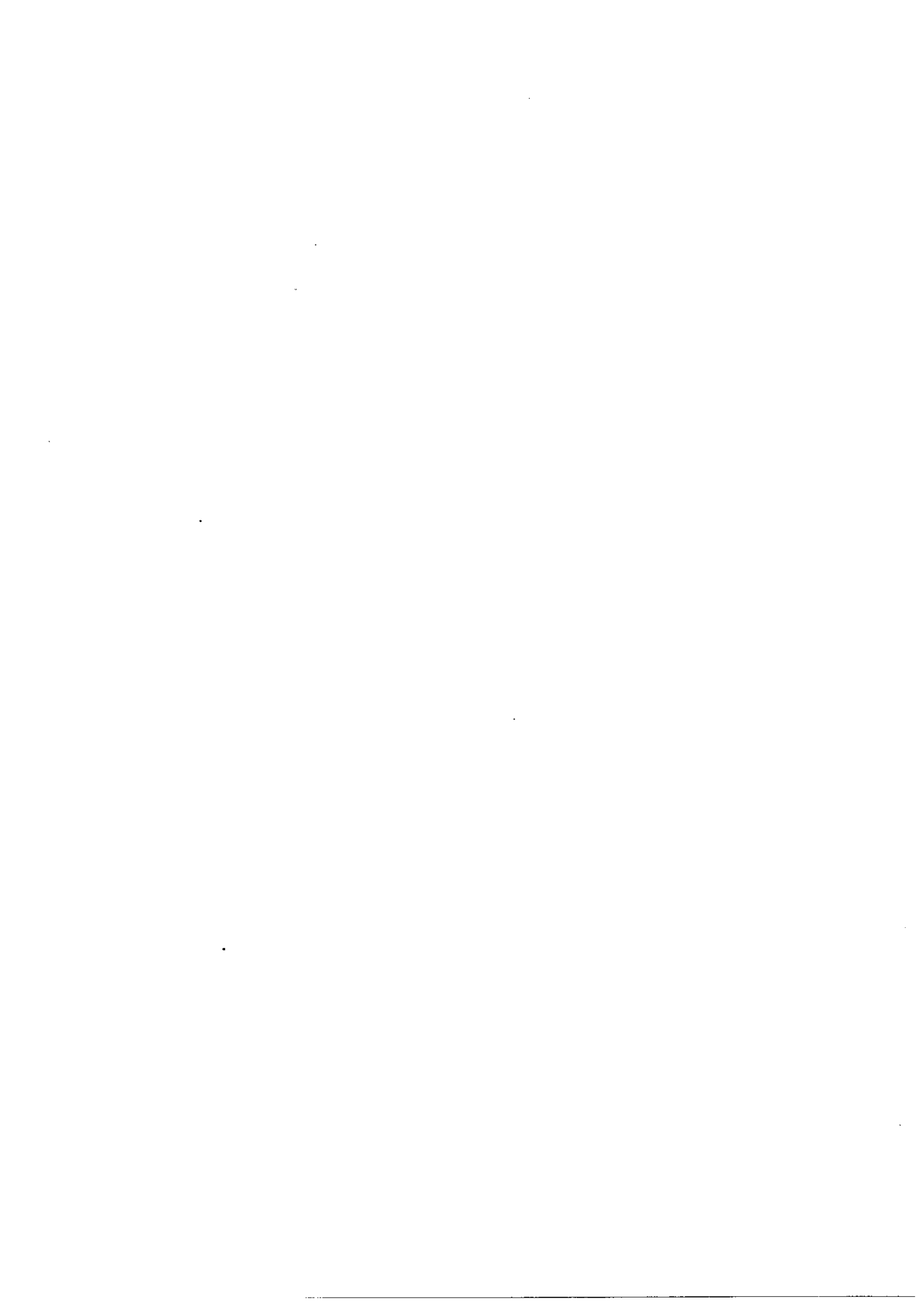

# ANSWER SHEET

**EXAM PAPER 2012**

**SCHOOL : TAO NAN  
SUBJECT : PRIMARY 5 SCIENCE**

**TERM : SA2**

Q1	Q2	Q3	Q4	Q5	Q6	Q7	Q8	Q9	Q10	Q11	Q12	Q13	Q14	Q15	Q16	Q17
2	2	3	3	4	1	2	1	3	3	2	4	2	4	2	3	1

Q18	Q19	Q20
2	1	3

21)a) Air in the beaker occupies space and since air can only be compressed to a certain extent, only a few drops of water flowed into the beaker.

b) It allows the air to escape from the beaker so that the water in the glass funnel can drip into the beaker more freely.

22)a) i) A ii) B

b) B C A

23)a) i) Leaves ii) Phloem

b) The leaves make food for the plant. Likewise, the kitchen also makes food for the diners in the restaurant, hence I think that the leaves matches the kitchen.

24)a)

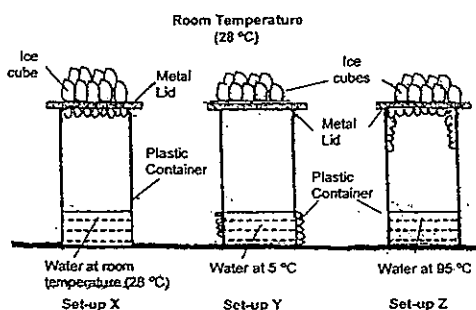

24)b)The water in Set-up Z is hotter than the water in Set-up X, hence the water evaporates faster. There is more water vapour that condenses on the cooler surface of the metal lid.

25)a)The longer be exercised, the faster the pulse rate and breathing rate.

b)It is to transport more oxygen and digested food to the muscles so that respiration can take place at a faster rate.

26)Since the water-carrying tubes are intact, the leaves can still receive water and make food. As the food-carrying tubes are removed, food made in the leaves cannot be transported to the lower part of the cut.

27)a)Cell wall.

b)In the leaves and stem.

c)It is the chloroplast. Cell A has chloroplast as the plant part which it is found in is exposed to light and makes food. While the root cell which is underground, does not need chlorophyll in the chloroplast, as no light is exposed to it.

28)a)X : Small Intestine      Y : Lungs

b)Arrow D. The large intestine absorbs water from the undigested food.

29)a)A is male and B is female. The female flowers can develop into fruits, while the male flowers cannot. In the graph, there are no fruits developed in A through out the sixty days, while there are eight-eight fruits developed in B, hence A is male and B is female.

b)The pollen grains from the anther will cling onto the bee and when the bee flies to anther flower the pollen grains will be brushed against the stigma.

30)a)While when the train is partially in the tunnel, only Metal Foil strip 1 will touch the metal foil , forming an open circuit, hence the bulb will only light up when the whole train completely enters the tunnel.

b)When the wires are connected, they form a closed circuit and enables the train to move. Hence, when the wire snaps, an open circuit is formed and the train will not be able to move.

31)a)As both Circuit A and Circuit B are arranged in series, Angelina was not able to come to a right conclusion.

b)

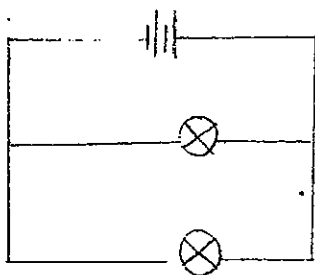

32)a)Steel    glass    Plastic    Wood

b)Steel is a good conductor of heat. It conducts the heat from the hot water to the thumbtack the fastest, hence the thumbtack will drop first.

c)Styrofoam is a poor conductor of heat so heat from the hot coffee is not easily transferred to the cup and the person holding the cup, hurting him or her.

33)a)It was to find out if the weight affected the time taken for the parachutes to reach the ground.

b)As the 70g weight is heavier than the 40g weight, there is more gravitational potential energy stored in it before was dropped. When it was dropping the gravitational potential energy was converted to kinetic energy and when the 70gweight hit the ground, the kinetic energy was converted to more heat energy and sound energy.

c)They did the experiment more than once.

34)a)The higher the dropping height, the higher the bouncing height of the ball.

b)At the point of release, the ball contains Gravitational Potential Energy. When it was released, the Gravitational Potential Energy the ball contained less Gravitational Potential Energy.

c)78cm.

